



# Table of Contents

Introduction .....	4
Controls .....	5
Operating Data .....	6
Displacement, Speed, and Pressure Ratings	
Overspeed Limits	
<b>PVE012</b>	
Model Number System .....	8
Shaft Torque Data .....	8
Performance Curves .....	9
Installation Dimensions .....	10
Shaft Options .....	10
Controls .....	11
Adjustable Maximum Volume Stop	
Load Sensing with Pressure Limiter	
Remote Adjustment Compensator	
<b>PVE19/21</b>	
Model Number System .....	14
Shaft Torque Data .....	16
Typical Rear Pumps for Thru-drives .....	16
Performance Curves .....	17
PVE19	
PVE21	
Installation Dimensions .....	19
Side Ports and C-type Control	
End Ports and C-type Control	
Controls .....	21
Adjustable Maximum Volume Stop	
Load Sensing with Pressure Limiter	
Remote Adjustment Compensator	
Unloading Valve	
Shaft Options .....	24
Thru-drives .....	25
PVE19/21 SAE "A"	
PVE19/21 SAE "B"	
Application Data .....	28

# Introduction to PVE Piston Pumps

Danfoss PVE piston pumps are inline, variable displacement pumps that are available in three displacement sizes. An assortment of optional controls offer maximum operating flexibility.

Pump displacement is varied by means of pressure and/or flow compensator controls.

## Features and Benefits

- Inline, variable displacement pump
- Displacement is varied by pressure/flow compensator controls
- Optional controls for maximum operating flexibility
- Thru-drive available on PVE 19/21

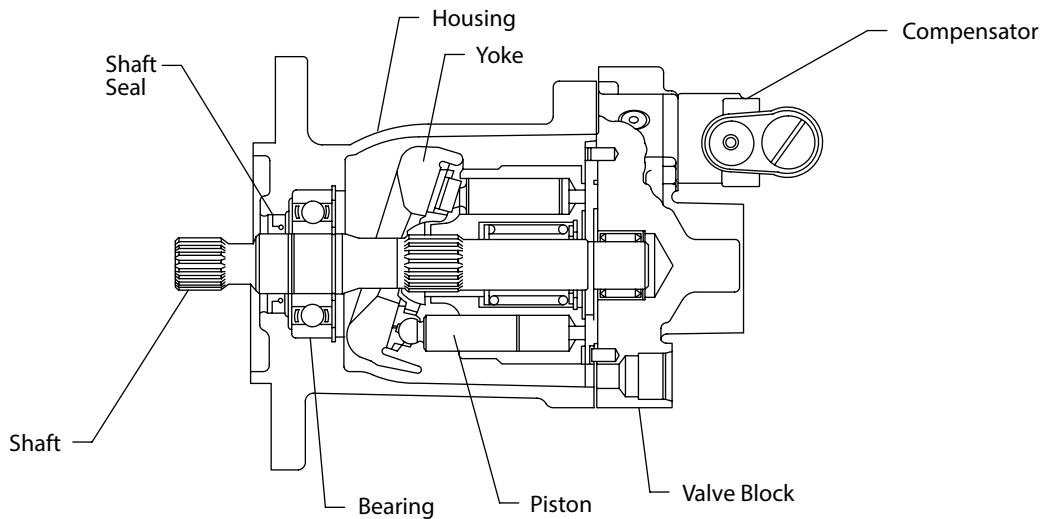

PVE012 Section V iew

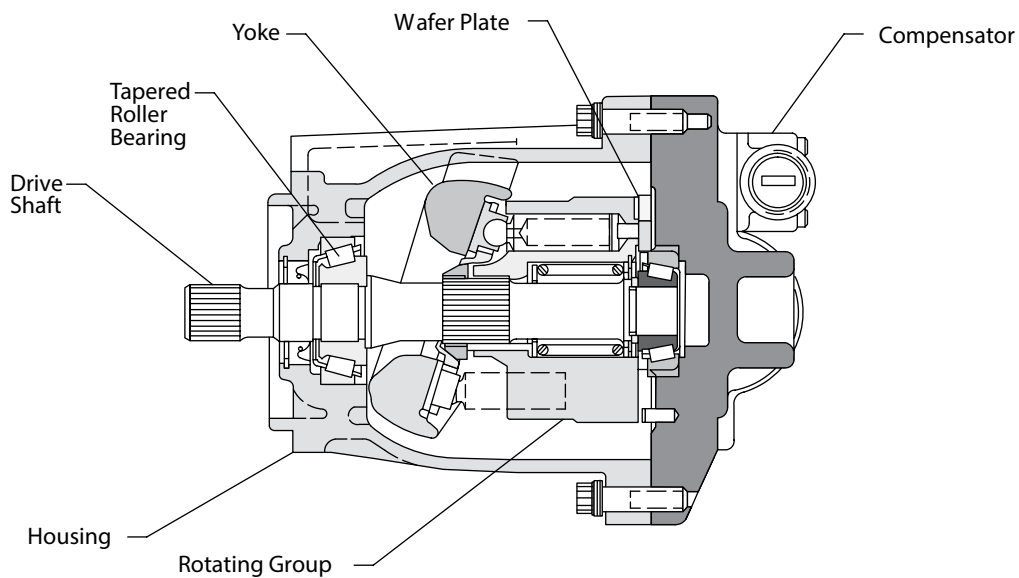

PVE012 Section V iew

Figure 1. Sectional V iews of the PVE Pumps

## Pressure Compensator Control, "A" Option

This control automatically varies pump displacement to meet the system flow demand for a constant system pressure. Displacement starts to reduce to zero within 14 bar (200 psi) of the compensator setting. Power draw-off is minimized, therefore, system relief valves should not be required.

## Pressure Compensator Control with Maximum Displacement Adjustment

As indicated for "A" option above, except there is an independent screw adjustment of maximum displacement from 100% (rated) to 25%.

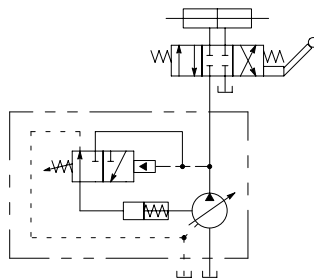

**Note:** Graphic symbols shown with external valve(s) and cylinder to illustrate typical usage.

## Load Sensing Compensator and Pressure Limiter, "B" Option

This compensator provides load sensing control under all pressure conditions up to the desired maximum. It automatically adjusts pump flow in response to a remote pressure signal and maintains outlet pressure at approximately 11 bar (160 psi) above load pressure. The integral pressure limiter overrides the load sensing control, reducing pump displacement as the preset maximum operating pressure is reached. Override begins within 14 bar (200 psi) of the preset maximum pressure compensator setting. A 24 bar LS option is also available.

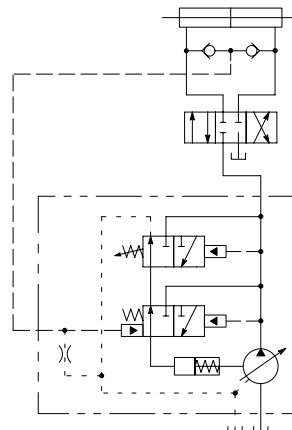

**Note:** Optional internal bleed orifice diameter is .015" and is "A" option-control special features.

## PVE with Pressure Compensator Arranged for Remote Control, "D" Option or "J" Option

Exactly the same as the "A" (pressure compensation option) except the machine operator is able to change the compensator setting through the use of a remote pilot relief valve.

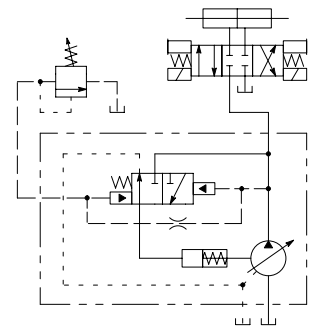

**Note:** A kit is available for an electrical dual pressure compensator. This control automatically adjusts pump delivery to maintain system volume requirements at either of two preselected operating pressures. This allows lower settings for low horsepower start-up, equipment testing, etc. This kit also allows for higher pressure settings as required in machine applications. For details refer to service drawing I-3255-S.

# Operating Data

## Displacement Speed, and Pressure Ratings

### Preparation for Start-up

Before starting a PVE pump, fill the case through the uppermost drain port with clean system hydraulic fluid. The case drain line must be connected to the reservoir below oil level. For multiple pump arrangements that include non-PVE sections, the requirements of the non-PVE units must also be considered.

### Mounting

Danfoss Hydraulics recommends these PVE series piston pumps be mounted horizontally.

### Displacement, Speed and Pressure Ratings

Model Number System	Displacement cm <sup>3</sup> /r (in <sup>3</sup> /r)		Rated Input Speed (At 0 psig Inlet)	Maximum Pressure bar (psi)
	Shaft End Pump	Cover End Pump		
PVE012	25 (1.54)	–	3000	210(3000)
PVE19	41 (2.50)	–	2400	210(3000)
PVE21	45 (2.75)	–	2400	186(2700)

\* Shaded product may not be available

### Pressure Limits

Port	Pressure Range
Inlet**	0,2 bar to 2,0 bar (5 in. Hg. vacuum to 30 psi)
Outlet	See Maximum Pressures listed above
Drain*	0,35 bar (5 psig) maximum

\* Integral relief valve protects pump by limiting case pressure peaks to 0,7 bar (10 psi) above inlet pressure. Flow from valve returned directly to pump inlet. Case drain line required to limit steady-state case pressure.

\*\* See page 9 for Inlet vs. Speed details.  
For non-intergrated units only

# Operating Data

## Displacement Speed, and Pressure Ratings

### At Full Flow Conditions

Displacement cm <sup>3</sup> /r (in <sup>3</sup> /r)	Inlet Pressure/Vacuum*	Maximum Speed** rpm
PVE21 full displacement 45 (2.75)	5 psig	2800
PVE19 full displacement 41 (2.50)	0 psig	2400
	5 in. Hg.	2100
	5 psig	3100
PVE19/21 destroyed 33 (2.00)	0 psig	2750
	5 in. Hg.	2500
	5 psig	3200
PVE19/21 destroyed 25 (1.50)	0 psig	3000
	5 in. Hg.	2850

PVE012 limited to 3000 rpm at full displacement and 0 psig inlet.

\* Minimum pressure/vacuum required at pump inlet to operate at displacement and speed listed.

\*\* Speeds not listed, but within displacements shown above, may be calculated from values listed.

### At Load Sense Standby Condition – “B” Option Controls

Model Number System	Maximum Speed rpm
PVE012	3600
PVE19	3200
PVE21	3200

Pump must be in zero flow, low pressure, standby condition when operated at listed speed. Pump may be damaged if not slowed to normal rated speed before being operated at full flow.

### Response Data

Control Type	PVE012		PVE19/21	
	On Stroke sec.	Off Stroke sec.	On Stroke sec.	Off Stroke sec.
Pressure compensator	0.030	0.012	0.050	0.025
Load sense compensator	0.040	0.012	0.060	0.020

Yoke response recorded at rated speed and pressure, 0 psi inlet, 82°C (180°F), SAE 10W oil.

Pressure rise was 6900 bar (100,000 psi) per second.

### Sound Data

Model Number System	1200 rpm, 70 bar (1000 psi)		1500 rpm, 140 bar (2000 psi)		1800 rpm, 210bar (3000 psi)	
	Full Stroke dB(A)	Compensated Stroke dB(A)	Full Stroke dB(A)	Compensated Stroke dB(A)	Full Stroke dB(A)	Compensated Stroke dB(A)
PVE012	71	65	76	72	77	77
PVE19	79	74	83	85	86	87
PVE21	75	73	79	81	83*	83*

\* 2700 psi

Sound level dB(A) per ISO 4412-1 standard.

# Model Code

E Series, PVE012 Pump

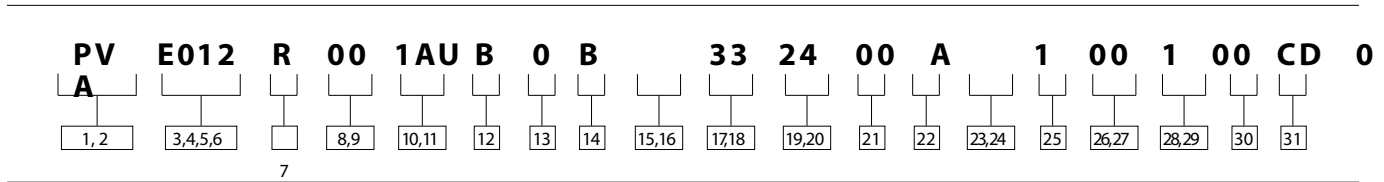

- 1,2 Pump Series**  
**PV** – Open Circuit Piston Pump
- 
- 3,4,5,6 Displacement**  
**E012** – 25.2cm<sup>3</sup>/r (1.54 in<sup>3</sup>/r)
- 
- 7 Input Shaft Rotation**  
**R** – Right-Hand Rotation (cw)  
**L** – Left-Hand Rotation (ccw)
- 
- 8,9 Front Mounting and Input Shaft**  
**01** – SAE B 2 bolt, Keyed  
**05** – SAE B 2 bolt, Splined 13t 16/32DP  
**09** – SAE B 2 bolt, Splined 26t 32/64DP
- 
- 10,11 Main Ports Location and Size**  
**AU** – End ports, SAE o-ring; #20 suction, #12 pressure  
**AV** – End ports, ISO 6149; M42 suction, M27 pressure
- 
- 12 Drain Port Size**  
**06** – M18 metric O-ring port – top (D1)  
**07** – M18 metric O-ring port – bottom (D2)

- B** – #8 SAE O-ring port – top (D1)  
**C** – #8 SAE O-ring port – bottom (D2)
- 
- 13 Diagnostic Pressure Port**  
**0** – No diagnostic pressure port
- 
- 14 Controller Type**  
**A** – Pressure Compensator  
**B** – Pressure and flow compensator  
**C** – Electric dual range pressure Compensator with directional control valve  
**D** – Hydraulic remote control pressure compensator  
**E** – Unloading valve (accumulator Circuits)  
**F** – Electric dual range pressure compensator without directional control valve
- 
- 15,16 Pressure Comp./Unloading Valve Setting**  
**00** – No pressure compensator setting  
**33** – 207-214 bar (3000-3100 psi)

- 17,18 Flow Comp. Setting or Unload Valve**  
**00** – No pressure compensator setting  
**11** – 9.65-12.41 bar (140-180 psi)  
**24** – 22.75-25.51 bar (330-370 psi)
- 
- 19,20 Secondary Compensator Setting**  
**00** – As Given in Code Title
- 
- 21 Control Special Features**  
**0** – No Special Features  
**A** – Bleed down orifice, LS only  
**B** – External load-sensing adjustment  
**G** – High rate spring for low pressure setting  
**J** – Bleed down orifice and high rate spring for low pressure setting
- 
- 22 Maximum Displacement Option**  
**1** – Standard adjustment  
**2** – Adjustable maximum displacement (set at maximum)

- 23,24 Auxiliary Mounting and Output Shaft**  
**00** – No auxiliary mounting or output shaft
- 
- 25 Shaft Seals**  
**0** – No shaft seal  
**1** – Standard shaft seal (nitrile)
- 
- 26,27 Special Features**  
**00** – No special features
- 
- 28,29 Paint**  
**00** – No paint  
**CD** – Blue primer
- 
- 30 Customer and unit identification**  
**0** – STD – mark assembly Number, full model code and build data Code on plate
- 
- 31 Design Code**  
**A** – First

**Note:** Consult a Danfoss representative for additional settings

## Shaft Torque Data

PVE012

PV E 012 Shaft Torque Data

Input Shaft Torque N.m (lb.in.)	Designation	Thru-drive Option	Maximum Input
01	SAE "B" straight keyed	No	135 (1200)
05	SAE "B" spline 13T, 16/32 D.P., FRMDF	No	208 (1850)
09	Special Danfoss 26T for use in rear pump of tandem PVE**-PVE12 unit	No	N/A



# Performance Curves

PVE012

Oil type: SAE 10W

Oil temperature: 49°C (180°F)

Inlet pressure: 0 psi

## Effective Flow Versus Speed

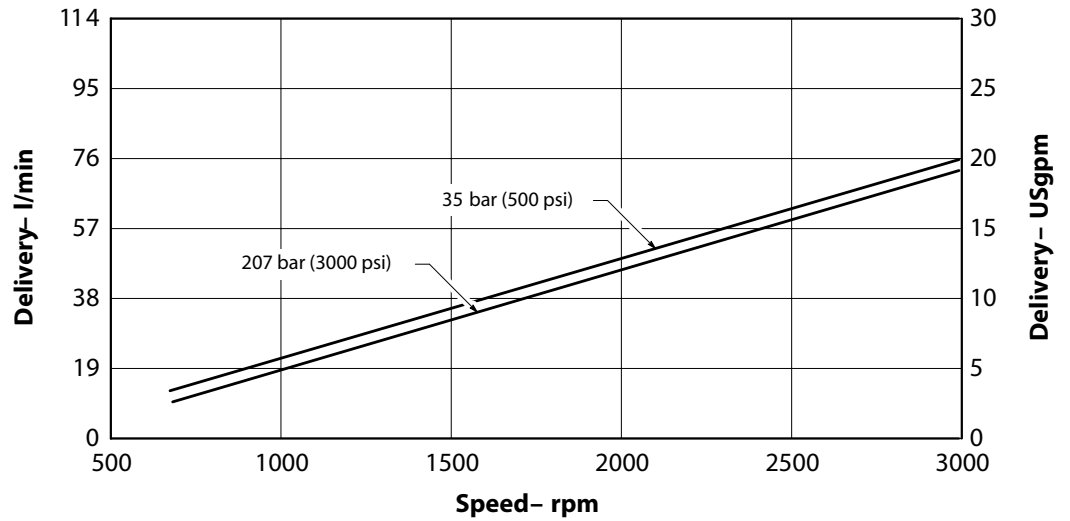

## Input Power Versus Speed

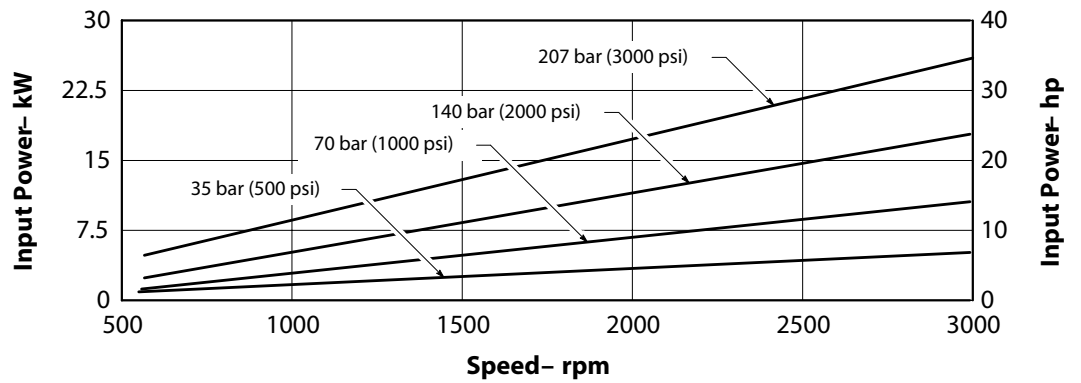

## Volumetric Efficiency Versus Speed

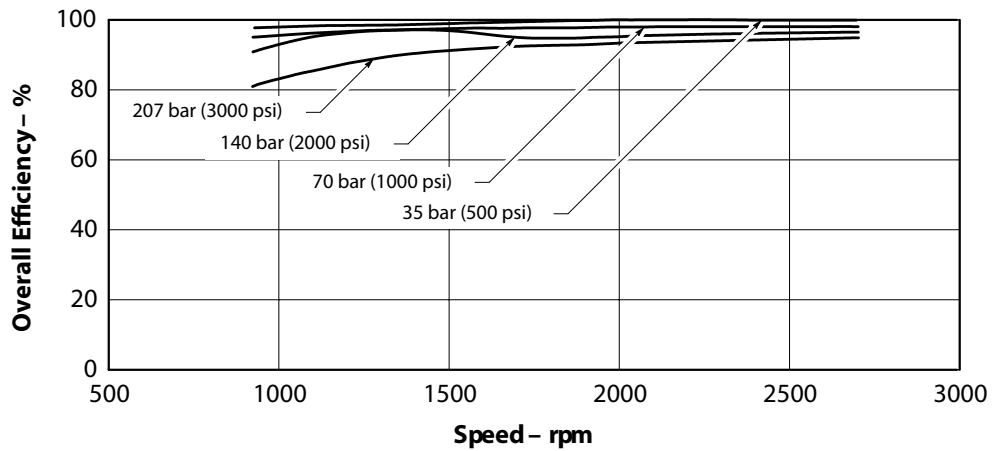

# Installation Dimensions

PVE012 with Pressure Compensator

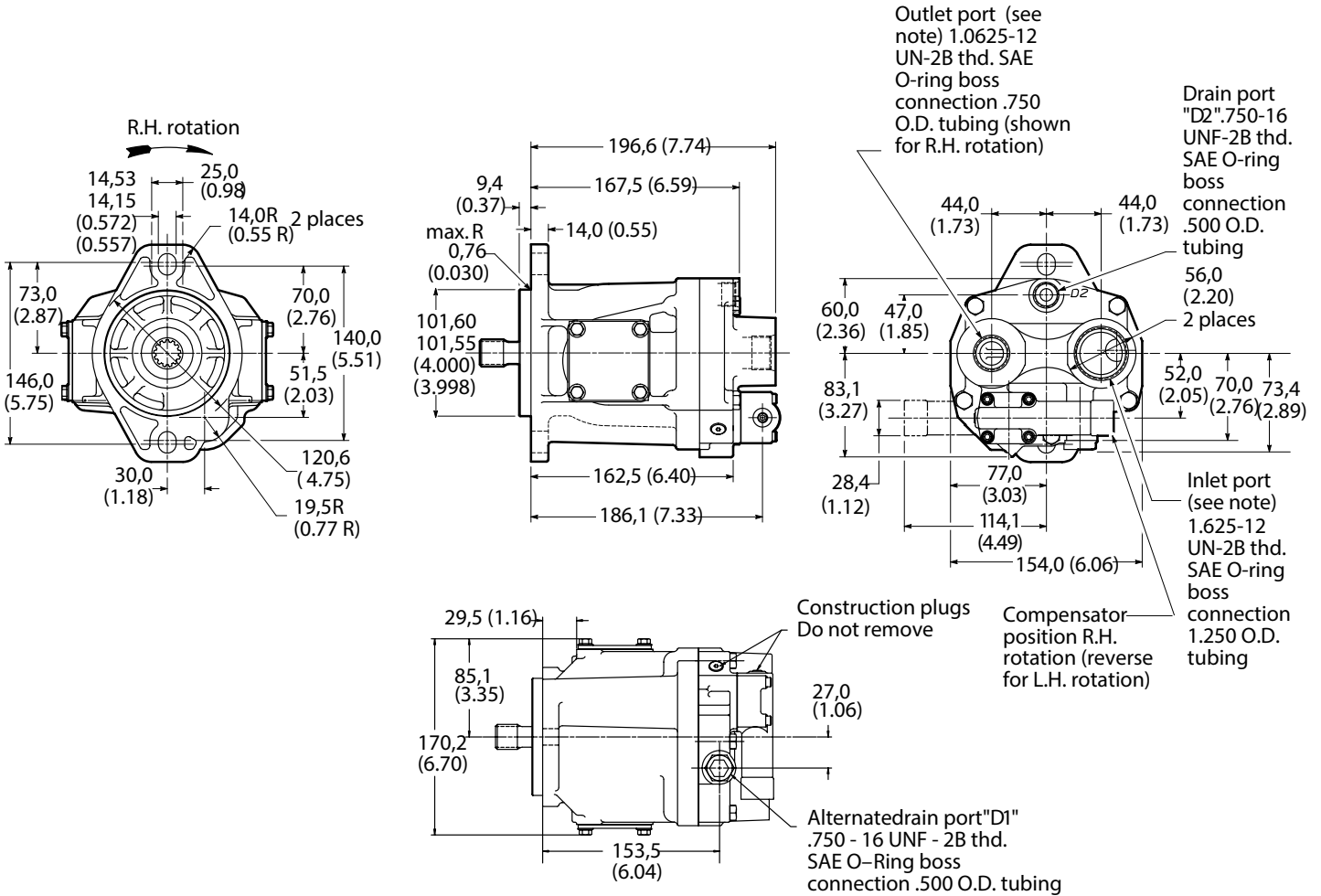

## PVE012 Shaft Options

### #01: SAE "B" Straight Keyed

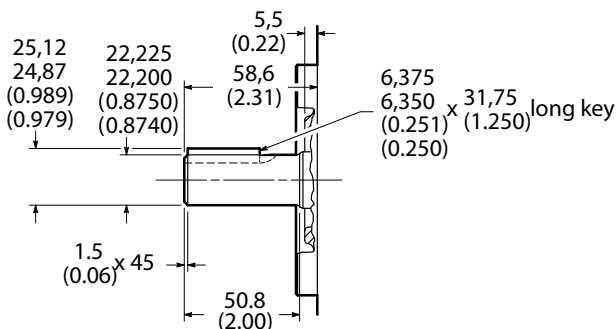

**Note:** Applications requiring overhung load or side loading of shaft are subject to Danfoss engineering approval.

### #05: SAE "B" Splined

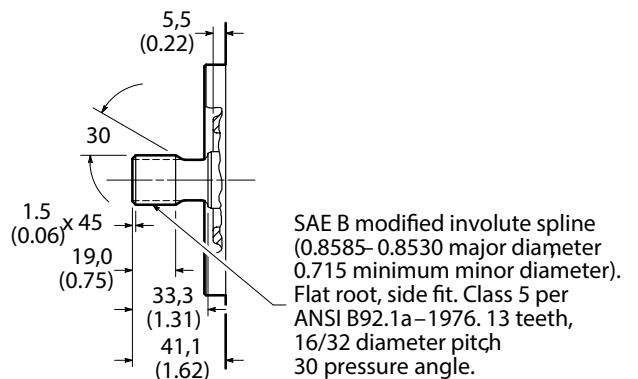

# Controls

PVE012

See installation dimensions page 10 for other details.

## Adjustment

Loosen the locknut on the adjusting rod. Turn the adjusting rod clockwise to decrease maximum pump delivery, or counterclockwise to increase maximum pump delivery, until the desired setting is obtained. Secure the setting by tightening the locknut. To assist initial priming, the manual adjustment control setting must be at least 40% of the maximum flow position.

This control enables maximum pump delivery to be externally adjusted from 25% to 100% while maintaining all the standard features of a pressure compensated pump.

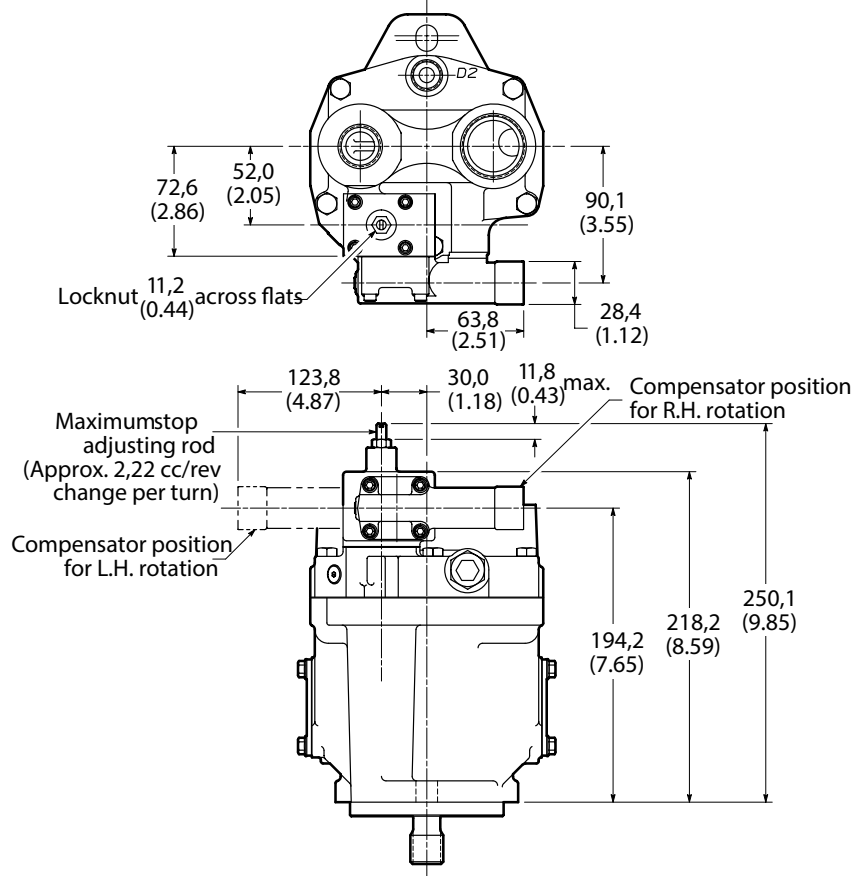

# Controls

PVE012

See installation dimensions  
page 10 for other details.

## PVE012 Load Sensing with Pressure Limiter "A" Control Option

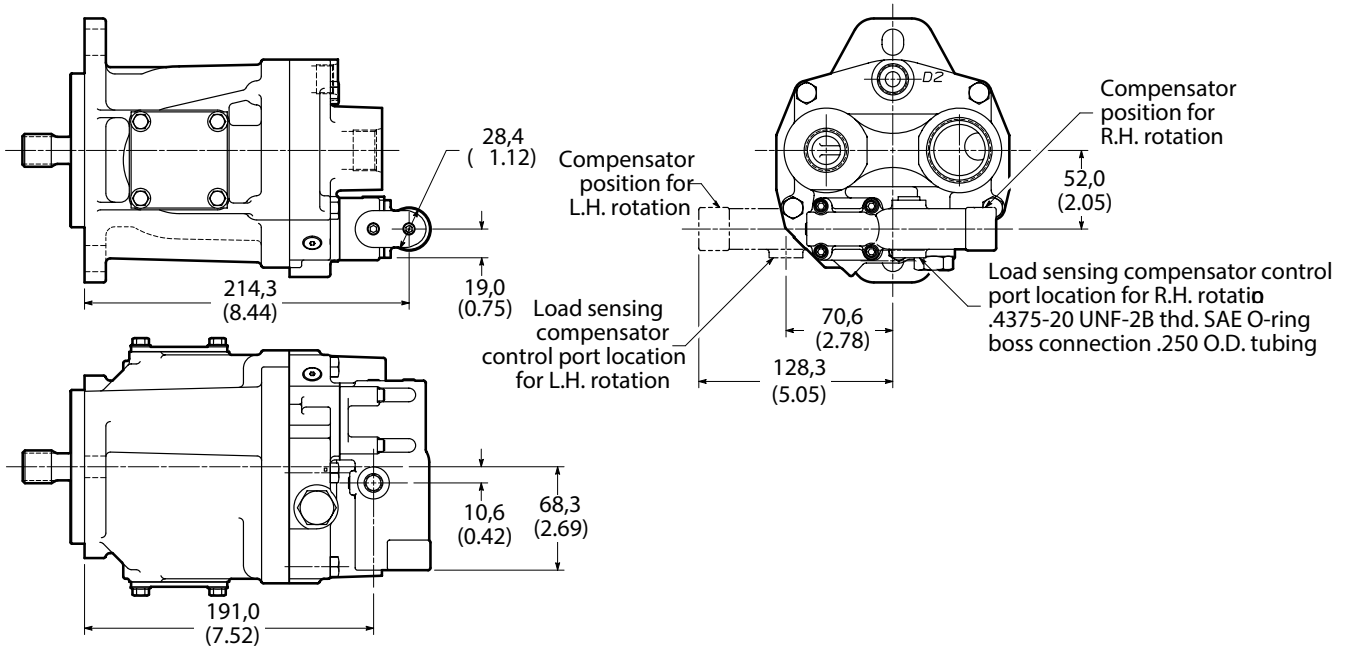

# Controls

## PVE012 Remote Adjustment Compensator

See installation dimensions  
page 10 for other details.

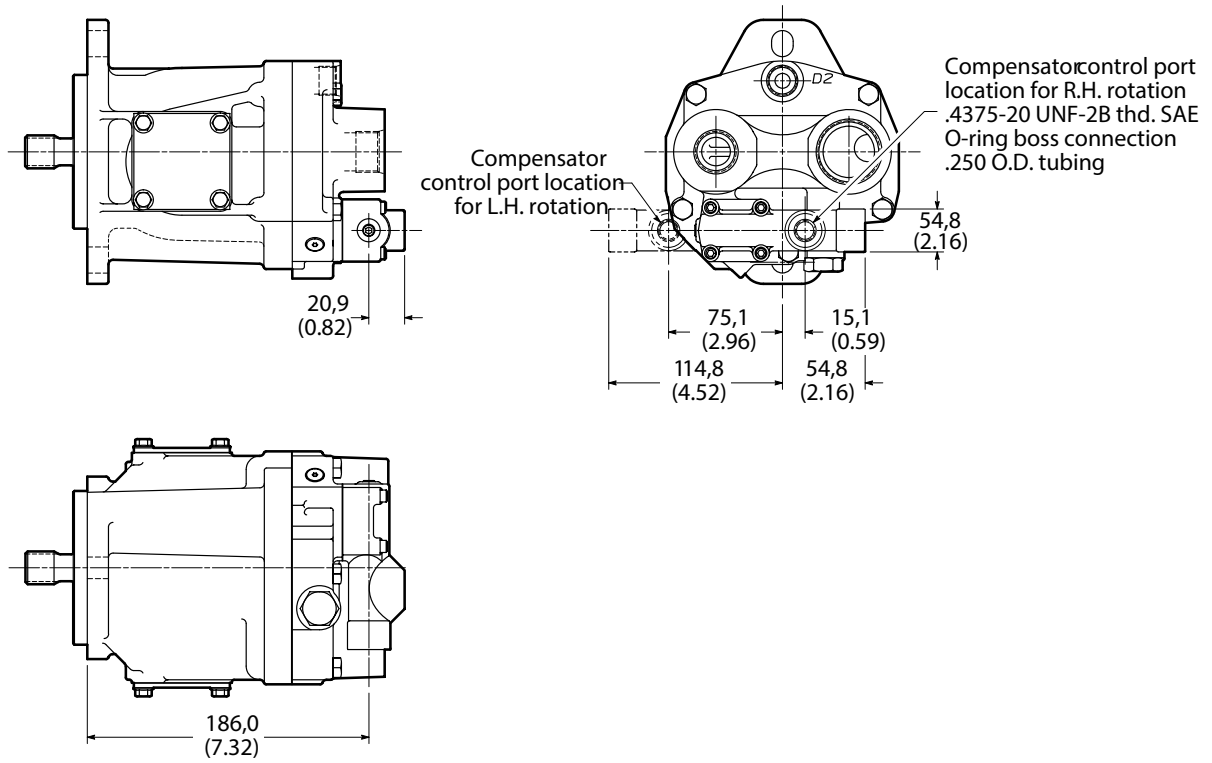

# Model Code

PVE19/21

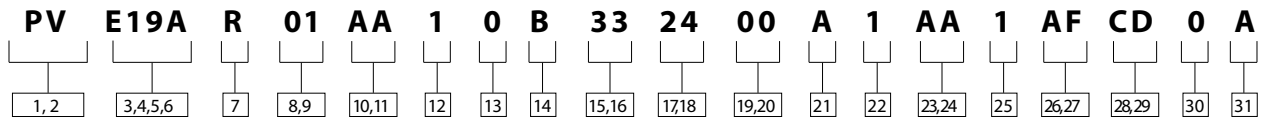

**1,2 Pump Series**  
**PV** – Open Circuit Piston Pump

**3,4,5,6 Displacement**  
**E19A** – 41.0cm<sup>3</sup>/r (2.50 in<sup>3</sup>/r)  
**E21A** – 45.1cm<sup>3</sup>/r (2.75 in<sup>3</sup>/r)

**7 Input Shaft Rotation**  
**R** – Right-Hand Rotation (cw)  
**L** – Left-Hand Rotation (ccw)

**8,9 Front Mounting and Input Shaft**  
**01** – SAE B 2 bolt, Keyed  
**02** – SAE B-B 2 bolt, Keyed  
**04** – SAE B 2 bolt, tapered  
**05** – SAE B 2 bolt, splined 13t 16/32DP long shaft  
**08** – SAE B-B 2 bolt, splined 15t 16/32DP  
**09** – SAE B 2 bolt, splined 26t 32/64DP

**10,11 Main Ports Location and Size**  
**AA** – Side ports, SAE o-ring; #24 suction, #14 pressure  
**AB** – End ports, SAE o-ring; #24 suction, #14 pressure  
**AC** – Side ports, SAE 4 bolt flange, Code 61; 1 1/2" suction, 1" pressure  
**AD** – End ports, SAE 4 bolt flange, Code 61; 1 1/2" suction, 1" pressure  
**AE** – Side ports, ISO 6149-1; M48 suction, M33 pressure  
**AF** – End ports, ISO 6149-1; M48 suction, M33 pressure  
**AS** – End ports ISO 6162 4 bolt flange; 1 1/2" suction, 1" pressure

**12 Drain Port Size and Location**  
**01** – #10 SAE O-ring port – top (D1)  
**02** – #10 SAE O-ring port – bottom (D2)  
**06** – M18 metric O-ring port – top (D1)  
**07** – M18 metric O-ring port – bottom (D2)

**13 Diagnostic Pressure Port**  
**0** – No diagnostic pressure port  
**1** – #4SAE O-ring port – plugged  
**2** – M14 metric O-ring port – plugged

**14 Controller Type**  
**A** – Pressure Compensator  
**B** – Pressure and flow compensator  
**C** – Electric dual range pressure compensator with directional control valve  
**D** – Hydraulic remote control pressure compensator  
**E** – Unloading valve (accumulator circuits)  
**F** – Electric dual range pressure compensator without directional control valve

**15,16 Pressure Comp./Unloading Valve Setting**  
**00** – No pressure compensator setting  
**18** – 182.7-189.6 bar (2650-2750 psi)  
**33** – 206.8-213.7 bar (3000-3100 psi)

**17,18 Flow Comp. Setting or Unload Valve**  
**00** – No pressure compensator setting  
**11** – 9.65-12.41 bar (140-180 psi)  
**14** – 12.41-15.17 bar (180-220 psi)  
**24** – 22.75-25.51 bar (330-370 psi)

**19,20 Secondary Compensator Setting**  
**00** – No secondary compensator setting  
**04** – 186.2-193.1 bar (2700-2800 psi)

**21 Control Special Features**  
**0** – No Special Features  
**A** – Bleed down orifice  
**B** – External load-sensing adjustment  
**G** – High rate spring for low pressure setting  
**J** – Bleed down orifice and high rate spring for low pressure setting

**Note:** Consult a Danfoss representative for additional settings

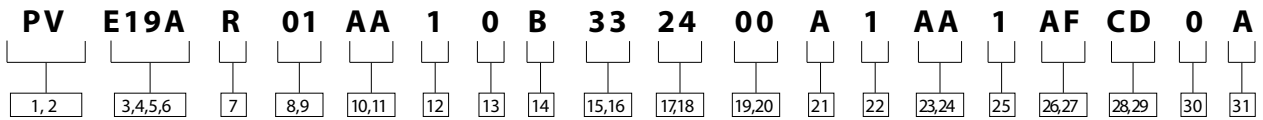

**22 Maximum Displacement Option**

- 1 – Standard adjustment
- 2 – Adjustable maximum displacement (set at maximum)

**23,24 Auxiliary Mounting and Output Shaft**

- 00 – No auxiliary mounting or output shaft
- AA – SAE A 2 bolt w/ 9T 16/32DP external splined shaft
- AB – 2 Bolt A (SAE J744-82-2) w/ 11T 16/32DP ex. splined shaft
- AC – SAE B 2 bolt w/ 13T 16/32 DP internal splined coupling
- AD – SAE B 2 bolt w/ 15T 16/32DP internal splined coupling
- AE – SAE B 2 bolt w/ 26T 32/64DP external splined shaft
- AH – SAE A 2 bolt w/ 9T 16/32DP internal splined coupling
- AJ – SAE A 2 bolt w/ 11T 16/32DP internal splined coupling
- AK – SAE B 2 bolt w/ 26T 32/64DP internal splined coupling

**25 Shaft Seals**

- 0 – No shaft seal
- 1 – Fluorocarbon shaft seal

**26,27 Special Features**

- 00 – No special features
- AA – Auxiliary mounting cover plate
- AF – Cast iron housing

**28,29 Paint**

- 00 – No paint
- CD – Blue primer

**30 Customer and unit identification**

- 0 – Standard Danfoss identification

**31 Design Code**

- A – First design

**Note:** Consult a Danfoss representative for additional settings

# Shaft Torque Data

PVE19/21

## Shaft Torque Data

Input Spline Data	Designation	Thru-drive Option	Maximum Torque N.m (lb.in.)
02	SAE "BB" straight keyed	Yes	215 (1900)
08	SAE "BB" spline 15T, 16/32 D.P., FRSF	Yes	337 (2987)
05	SAE "B" spline 13T, 16/32 D.P., FRSF	Yes	208 (1850)
01	SAE "B" straight keyed	No	135 (1200)
09	Special Danfoss 26T for use in rear pump of tandem PVE**-PVE** unit	No	N/A

**Note:** See page 22 for more details.

## Typical Rear Pumps for Thru-drives

PVE19/21

### Typical Rear Pumps for Thru-Drives

Model Code	Typical Rear Pump Model	Rear Pump Shaft Code	PVE** Thru-drive Coupling
AH	PVQ10/13	3	864224 (9T / 9T Straight)
	PVB5/6	Suffix -S214	
	V10	11	
	V20	62	
AC	PVE012	5	864307 (26T / 13T Step)
	PVE19/21	5	
	PVQ20/32	3	
	PVQ40/45	5	
	V2010 or V2020	11	
	20V(Q)	151	
AD	PVE19/21	8	475134 (26T / 15T Step)
	PVQ40/45	8	
	2520V(Q)	166	
AK	PVE012	9	627168 (26T / 26T Straight)
	PVE19/21		
	N/C		
	PVQ40/45		



# Performance Curves

PVE19

Oil type: SAE 10W

Oil temperature: 82°C (180°F)

Inlet pressure: 0 psi

## Effective Flow Versus Speed

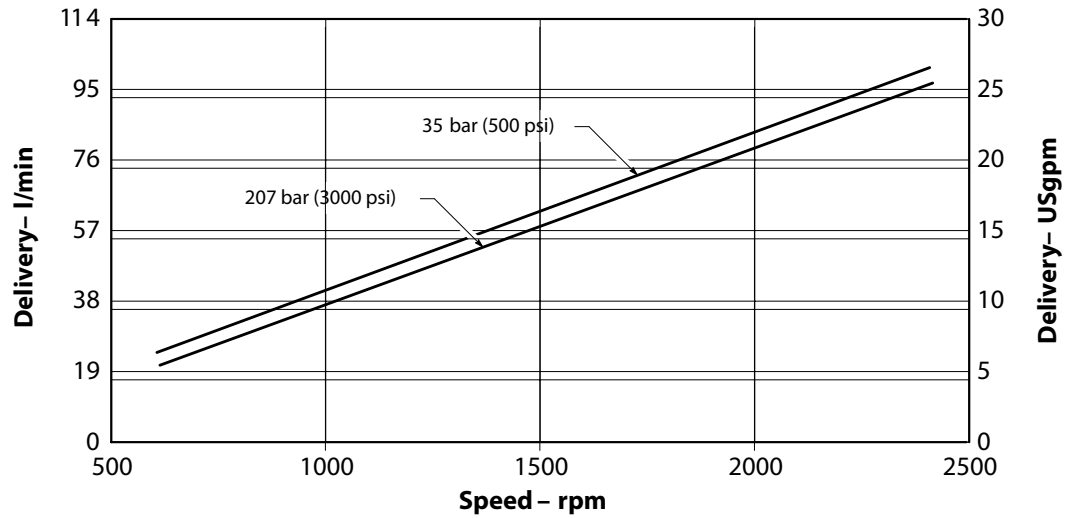

## Input Power Versus Speed

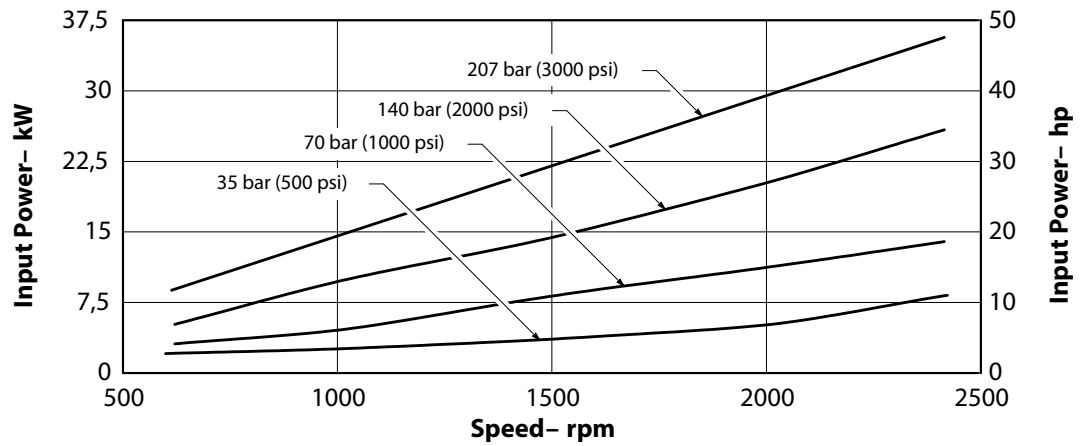

## Overall Efficiency Versus Speed

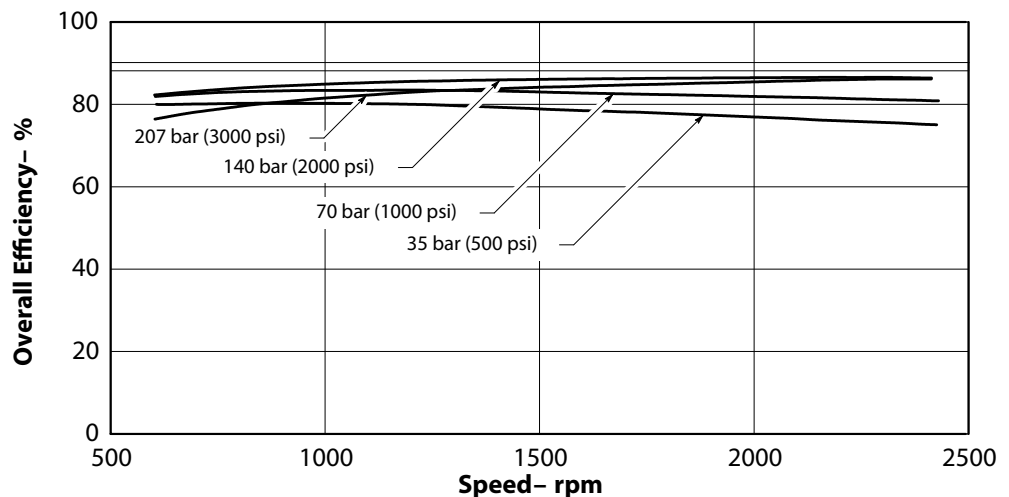

# Performance Curves

PVE19

Oil type: SAE 10W

Oil temperature: 82°C (180°F)

Inlet pressure: 0 psi

## Effective Flow Versus Speed

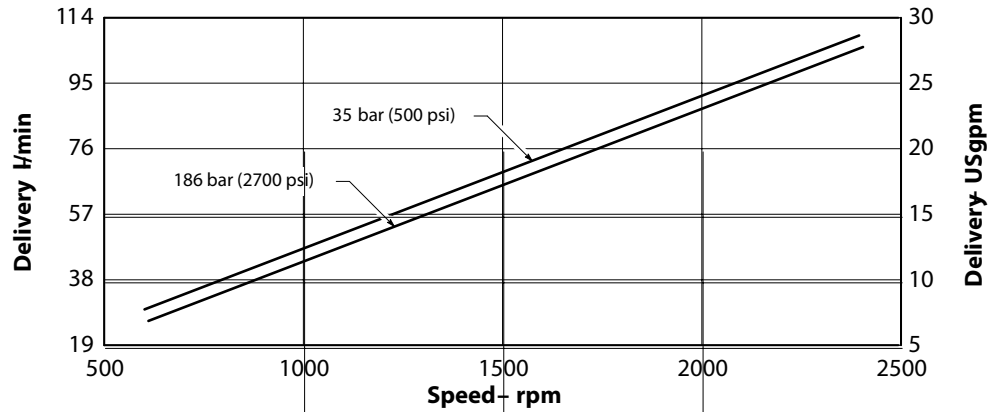

## Input Power Versus Speed

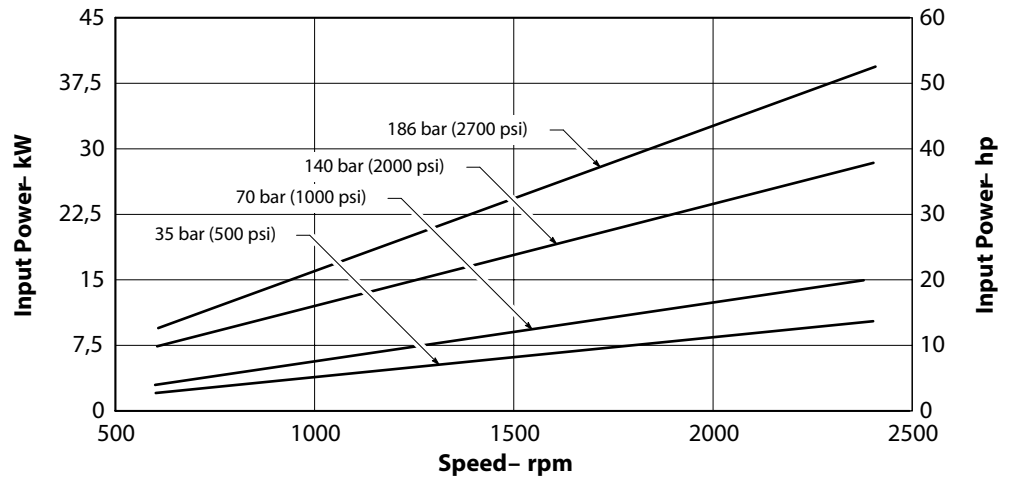

## Overall Efficiency Versus Speed

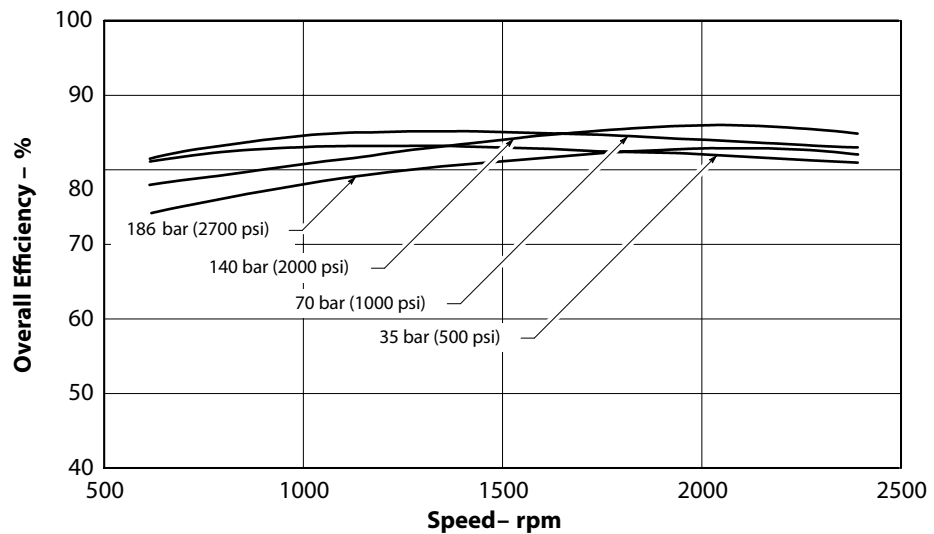

# Installation Dimensions

PVE19/21 with Side Ports

Millimeters (inches)

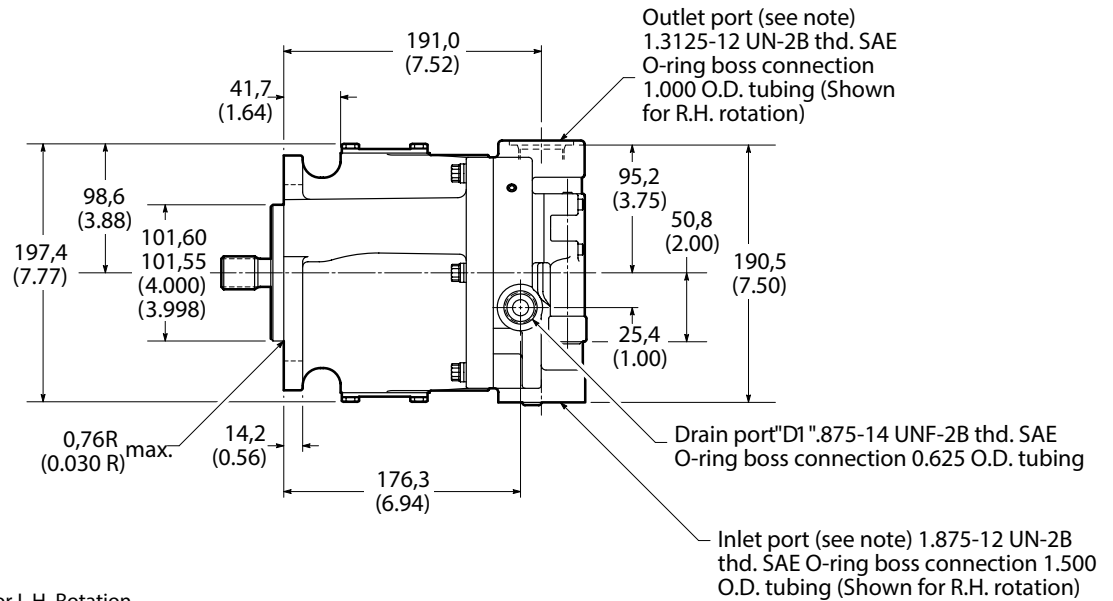

**Note :** Ports are reversed for L.H. Rotation

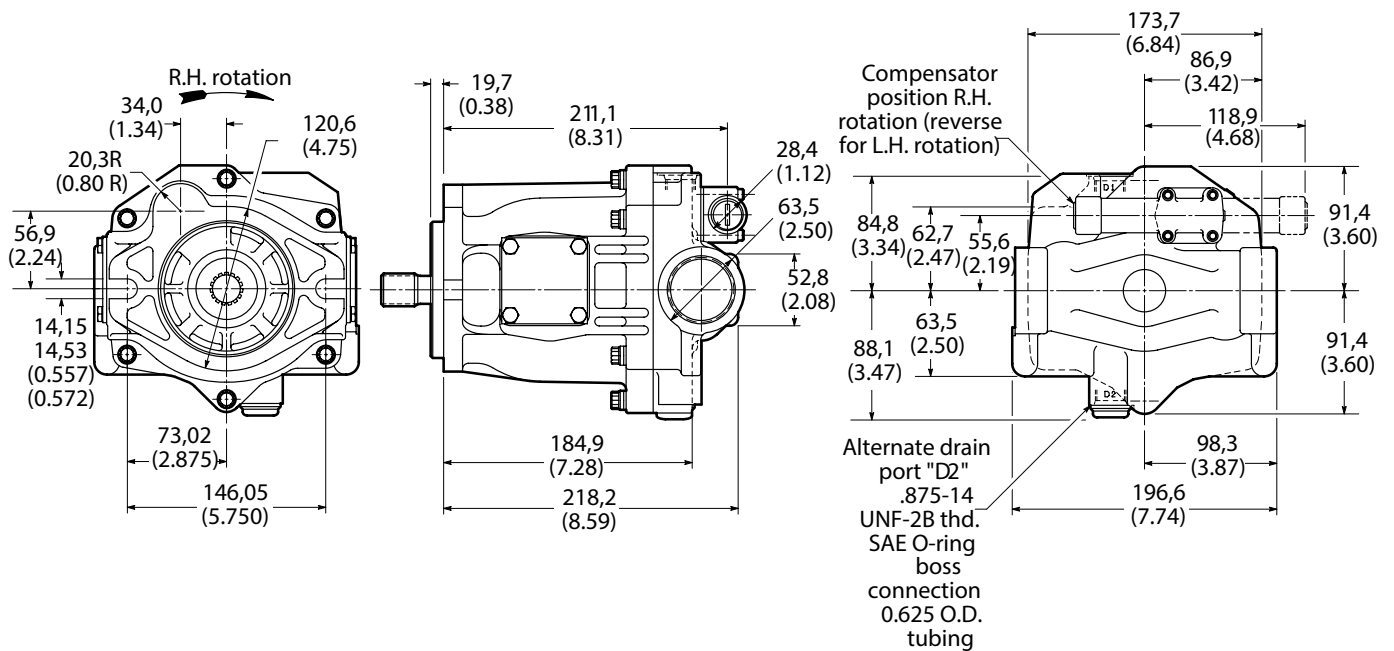

# Installation Dimensions

PVE19/21 with End Ports

Millimeters (inches)

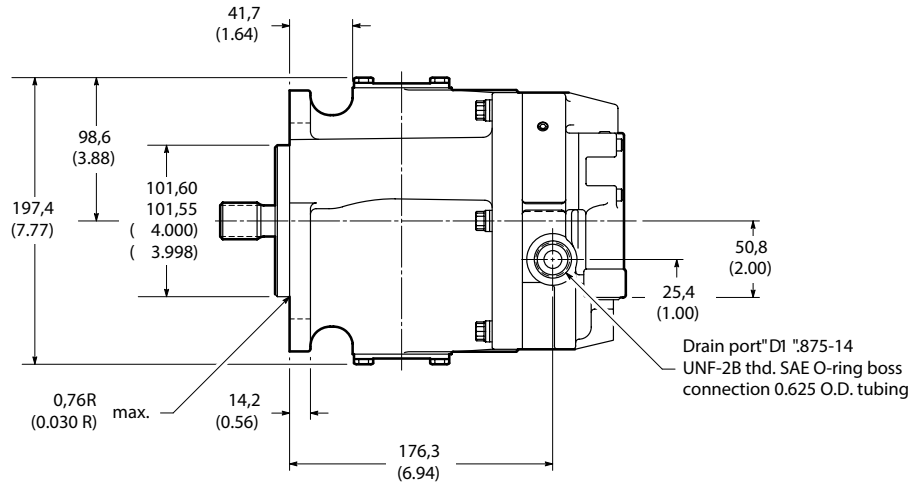

**Note :** Ports are reversed for L.H. Rotation

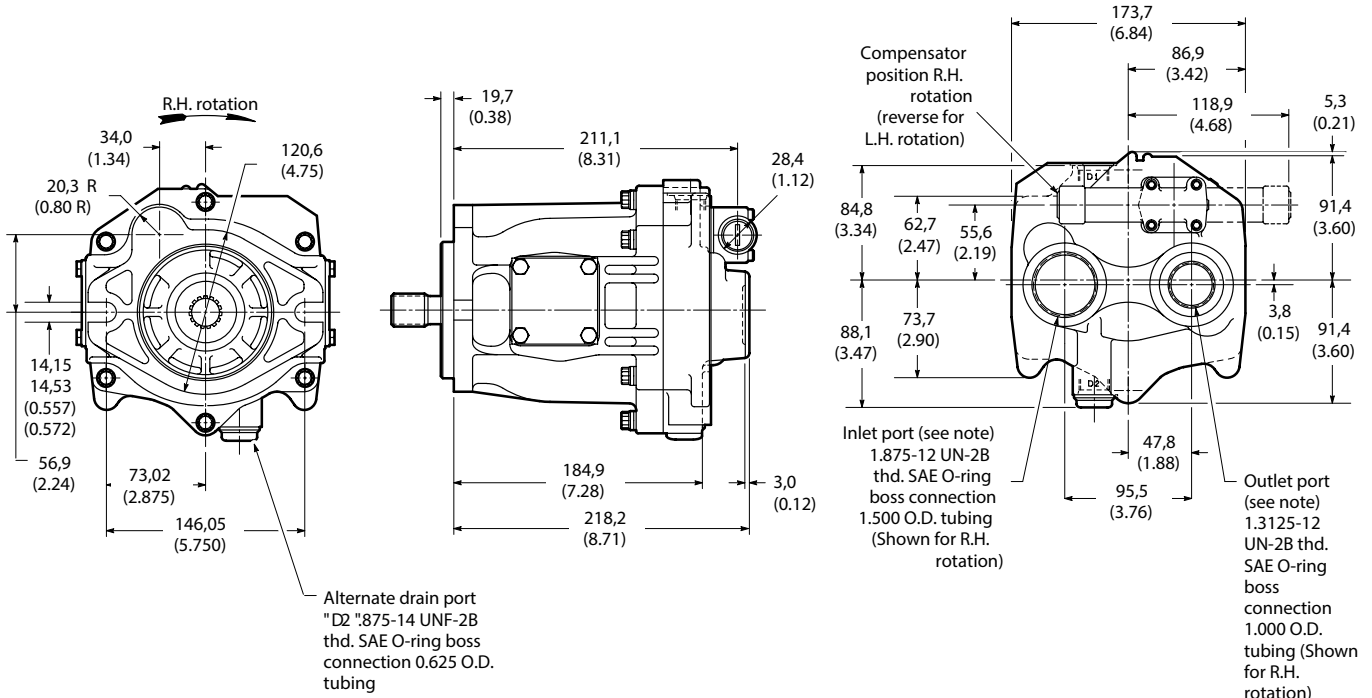

# Controls

## PVE19/21 Adjustable Maximum Displacement Stop

### Adjustment

Loosen the locknut on the adjusting rod. Turn the adjusting rod clockwise to decrease maximum pump delivery, or counterclockwise to increase maximum pump delivery, until the desired setting is obtained. Secure the setting by tightening the locknut. To assist initial priming, the manual adjustment control setting must be at least 40% of the maximum flow position.

This control enables maximum pump delivery to be externally adjusted from 25% to 100% (it is not recommended below 50%) while maintaining all the standard features of a pressure compensated pump.

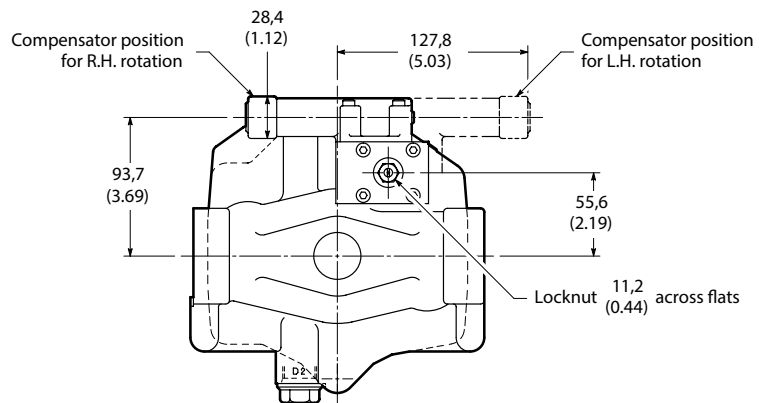
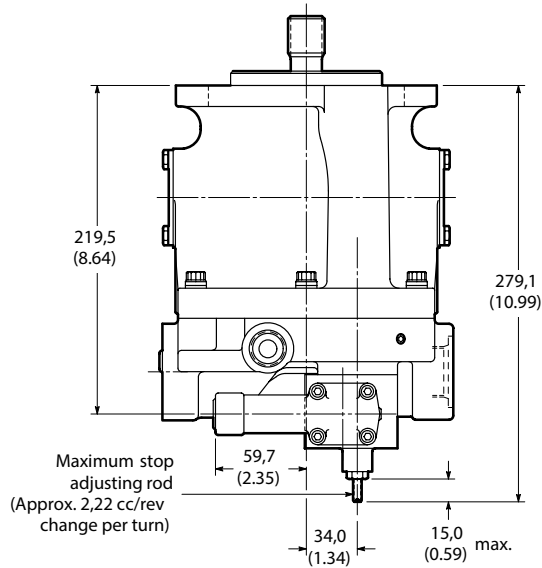

# Controls

PVE19/21

## PVE19/21 Load Sensing with Pressure Limiter Control "B" Option

See pages 19-20 for other details and dimensions.

## PVE19/21 Remote Adjustment Compensator Control "D" Option

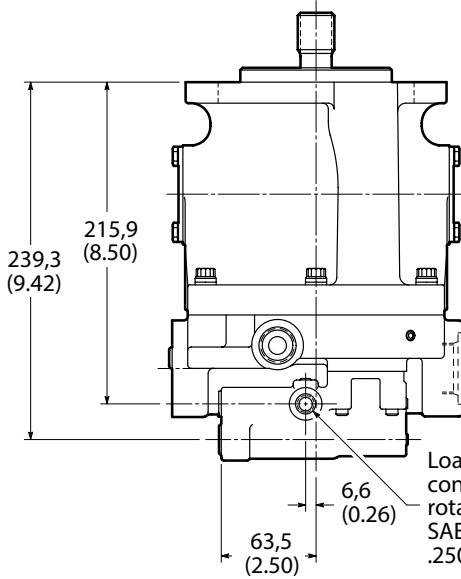

Load sensing compensator control port location for R.H. rotation .4375-20 UNF-2B thd. SAE O-ring boss connection .250 O.D. tubing

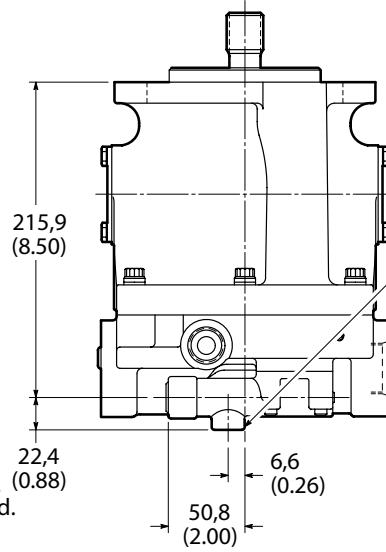

Compensator control port location for R.H. rotation .4375-20 UNF-2B thd. SAE O-ring boss connection .250 O.D. tubing

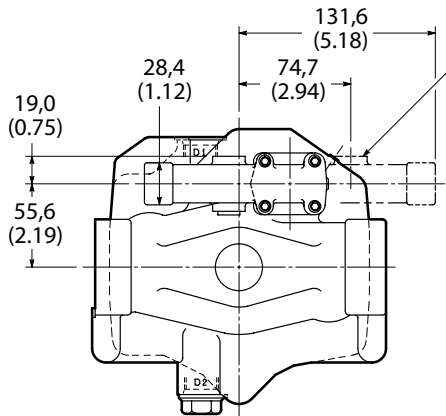

Load sensing compensator control port location for L.H. rotation

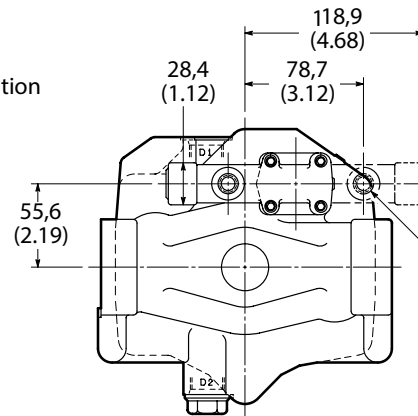

Compensator control port location for L.H. rotation

# Controls

## Unloading Valve Control – “E” Option

With the unloading valve control the variable pump will unload at a preset pressure. The pump will maintain this no flow, low pressure (approximately 14 bar (200 psi)) standby condition, until system pressure drops to about 85% of the preset unloading pressure. The pump will then return on stroke and provide full flow until the preset unloading pressure is reached again.

With this control, an efficient accumulator charging circuit is obtained. The pump will provide full flow to fill the accumulator until the maximum charging pressure is reached. The pump then goes to a standby condition until the accumulator pressure drops to 85% of the desired maximum. The accumulator is then recharged as the cycle starts over again.

A separate right angle check valve must be provided to maintain the accumulator hydraulic charge and prevent back flow when the pump is unloaded. The check valve's internal leakage must not exceed five drops per minute. The control port must be connected to system pressure, downstream of the check valve.

### Adjustment range

PVE19	100-210 bar (1500-3000 psi)
PVE21	100-186 bar (1500-2700 psi)

Cut-in pressure is 85% of unloading pressure, minimum.

### Setting Pressures

1. Back out accumulator unloading pressure adjustment screw to below desired unloading pressure.
2. Adjust desired standby pressure.
3. Set accumulator pressure by screwing in the accumulator unloading adjustment screw. Accumulator recharge (cut-in) pressure is a function of the maximum accumulator pressure and is not adjustable.
4. Check pressure settings and re-adjust if necessary.

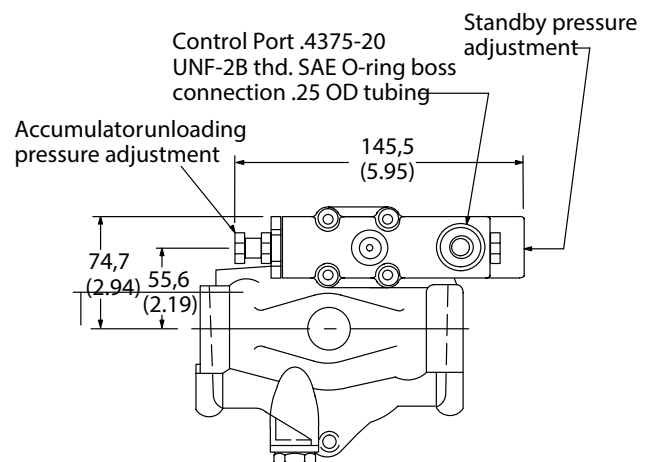
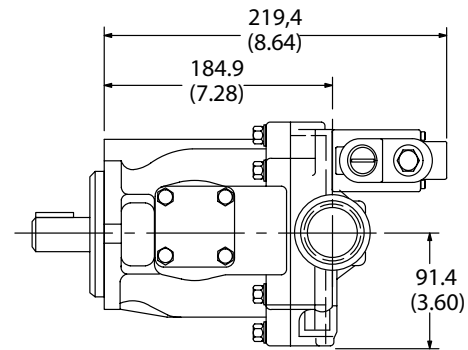
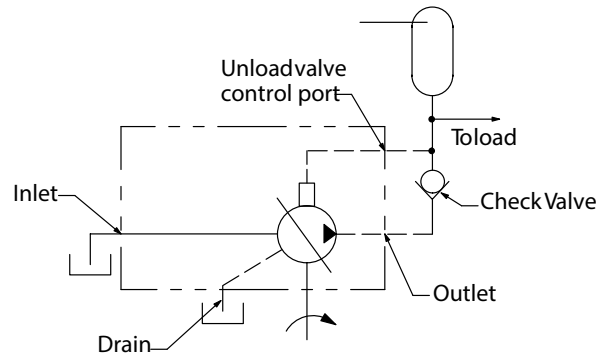

# Shaft Options

PVE19/21

## No. 04 Shaft: Tapered Key shaft

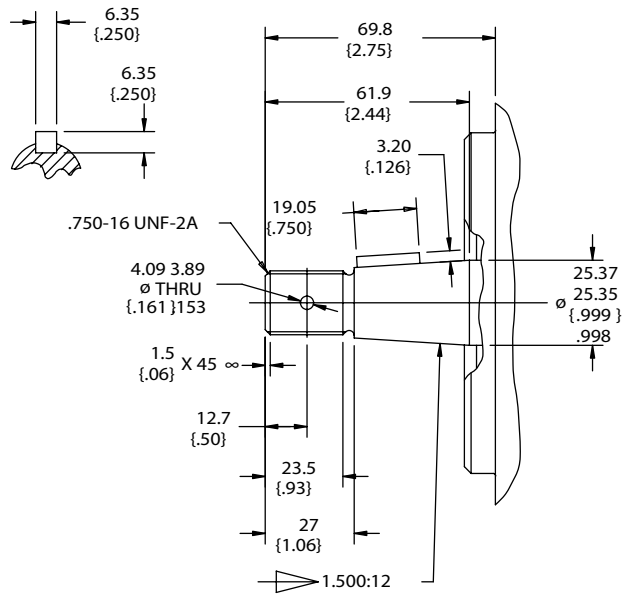

## No. 02 Shaft: SAE "BB" Straight Keyed

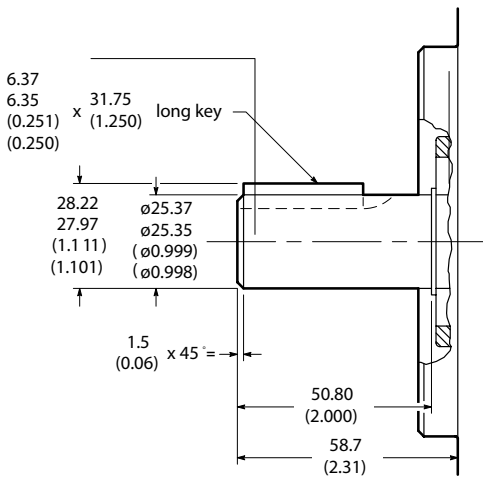

## No. 08 Shaft: SAE "BB" Splined

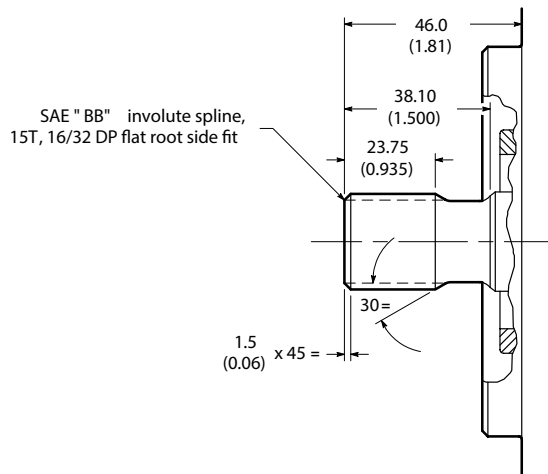

## No. 05 Shaft: SAE "B" Splined

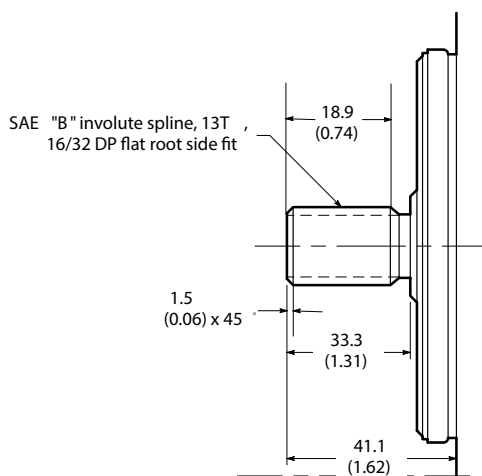

## No. 01 Shaft: SAE "B" Straight Keyed

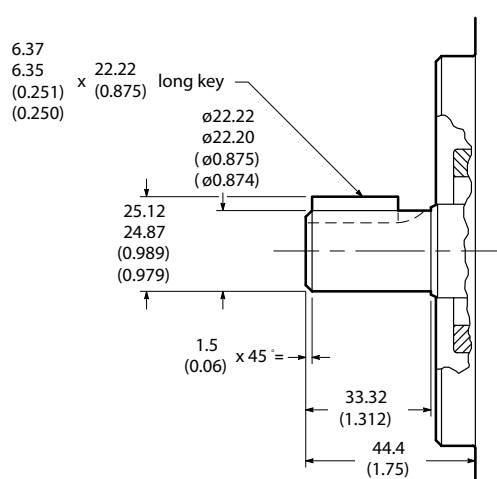



# Thru-drives

## PVE19/21 SAE "A" Thru-drives

Millimeters (inches)

PVE 19/21 S AE "A" Thru-drives

Thru-shaft	Spline Data	DIM. "A" mm (in.)	DIM. "B" mm (in.)	DIM. "C" mm (in.)	Max Torque Rating N.m (In. lbs.)	Coupling Length Dim "D" mm (in.)
AA	9 teeth 16/32DP Flat Root Side Fit	50,8 (2.00)	12,7 (0.50)	22,6 (0.89)	58 (517)	864224 62,7 (2.47) 62,2 (2.45)
AB	11 teeth 16/32DP Flat Root Side Fit	50,8 (2.00)	14,5 (0.57)	22,6 (0.89)	123 (1100)	864325 60,9 (2.40) 60,7 (2.39)

**Note:** Couplings, screws and washers must be ordered separately to mount rear pump. "A" O-ring (AS568-042) is included with each thru-drive pump.

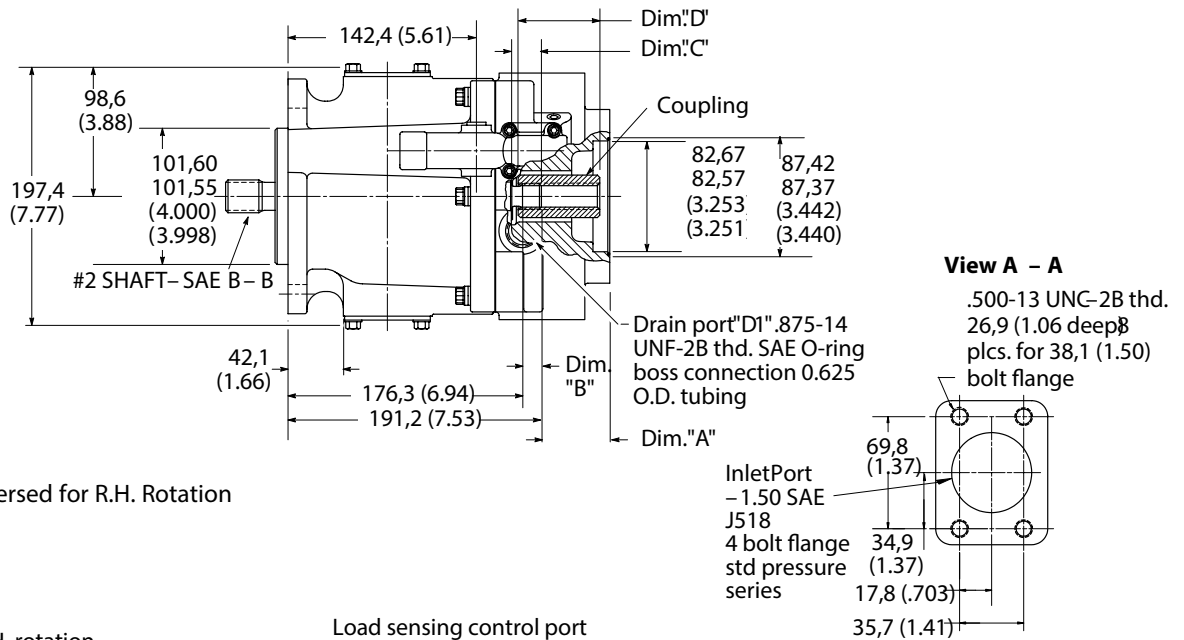

**Note :** Ports are reversed for R.H. Rotation

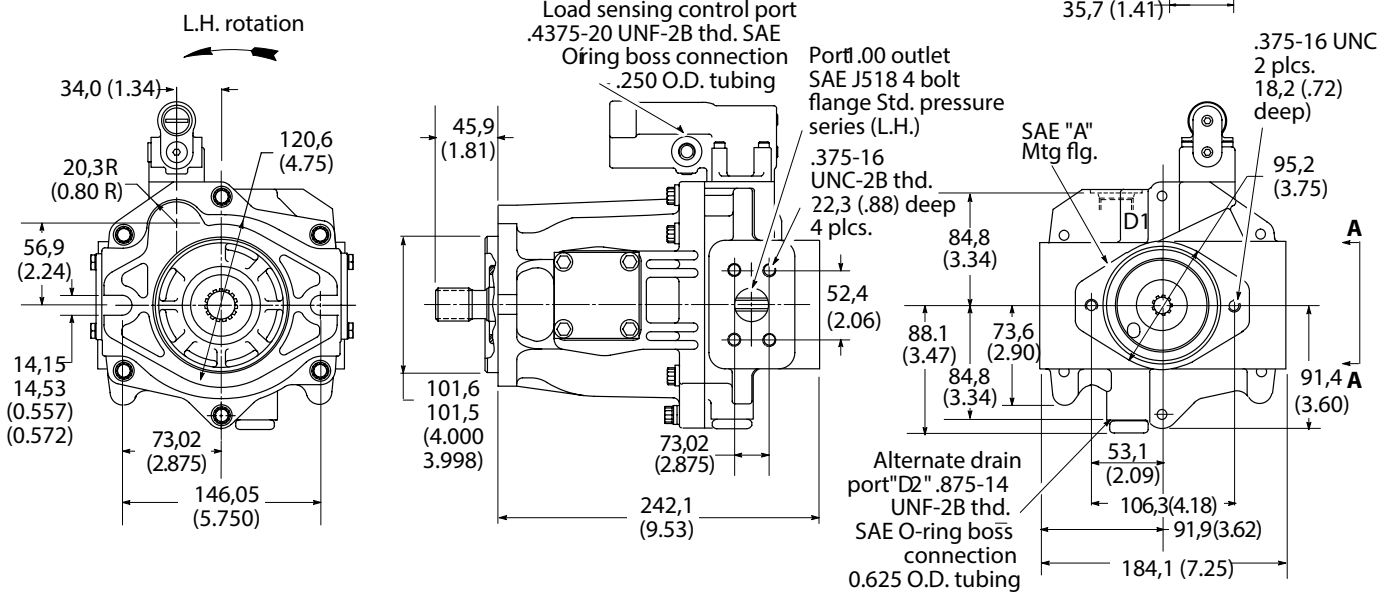



# Thru-drives

## PVE19/21 SAE "B" Thru-drives

Millimeters (inches)

### Thru-drive Pump Support Bracket

An optional support bracket should be used when a heavy second pump is mounted to a thru-drive PVE19/21. The support bracket (627179), two screws (199740), and two washers (427700) must be ordered separately.

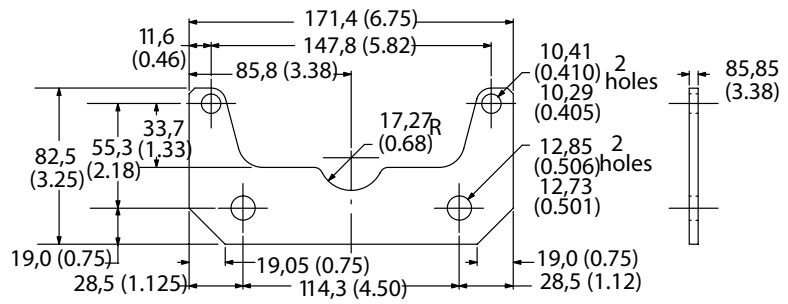

# Application Data

## Fluid Cleanliness

Proper fluid condition is essential for long and satisfactory life of hydraulic components and systems. Hydraulic fluid must have the correct balance of cleanliness, materials, and additives for protection against wear of components, elevated viscosity, and inclusion of air. Fluid contamination levels according to ISO4406 should not exceed 21/18/13 for PVE Piston pumps.

Essential information on the correct methods for treating hydraulic fluid is included in Danfoss publication 561 "Danfoss Guide to Systemic Contamination Control" available from your local Danfoss distributor or by contacting Danfoss Hydraulics. Recommendations on filtration and the selection of products to control fluid condition are included in 561.

Recommended cleanliness levels, using petroleum oil under common conditions, are based on the highest fluid pressure levels in the system and are coded in the chart below. Fluids other than petroleum, severe service cycles, or temperature extremes are cause for adjustment of these cleanliness codes. See Danfoss publication 561 for exact details.

Danfoss products, as any components, will operate with apparent satisfaction in fluids with higher cleanliness codes than those described. Other manufacturers will often recommend levels above those specified. Experience has shown, however, that life of any hydraulic component is shortened in fluids with higher cleanliness codes than those listed below. These codes have been proven to provide a long, trouble-free service life for the products shown, regardless of the manufacturer.

## Fire resistant fluids

Water glycol, phosphate ester and polyol ester fluids may be used with PVE pumps. With the PVE012 and PVE19, system pressure and input speed should not exceed 140 bar (2000 psi) and 1800 r/min.

System temperature should not exceed 54°C (130°F). Inlet vacuum should not exceed 101,6 millibar (3 in. Hg.).

## Hydraulic fluids and temperature ranges

Use antiwear hydraulic oil, or automotive type crankcase oil designations SC, SD, SE or SF per SAE J183FEB80.

Select a viscosity grade that will allow optimum viscosity, between 40 cSt (180 SUS) and 16 cSt (80 SUS), to be achieved within the optimum performance envelope shown.

For further information, see Danfoss Hydraulic Hints and Trouble Shooting Guide.

## Ordering procedure

Order PVE pumps by the full model designation. Pump displacement, mounting flange type, direction of rotation, pump configuration, shaft end type, seals, pressure adjustment range, specific control functions are all specified in the full model code.

# Notes

### Products we offer:

- Cartridge valves
- DCV directional control valves
- Electric converters
- Electric machines
- Electric motors
- Gear motors
- Gear pumps
- Hydraulic integrated circuits (HICs)
- Hydrostatic motors
- Hydrostatic pumps
- Orbital motors
- PLUS+1® controllers
- PLUS+1® displays
- PLUS+1® joysticks and pedals
- PLUS+1® operator interfaces
- PLUS+1® sensors
- PLUS+1® software
- PLUS+1® software services, support and training
- Position controls and sensors
- PVG proportional valves
- Steering components and systems
- Telematics

**Danfoss Power Solutions** is a global manufacturer and supplier of high-quality hydraulic and electric components. We specialize in providing state-of-the-art technology and solutions that excel in the harsh operating conditions of the mobile off-highway market as well as the marine sector. Building on our extensive applications expertise, we work closely with you to ensure exceptional performance for a broad range of applications. We help you and other customers around the world speed up system development, reduce costs and bring vehicles and vessels to market faster.

Danfoss Power Solutions – your strongest partner in mobile hydraulics and mobile electrification.

### Go to [www.danfoss.com](http://www.danfoss.com) for further product information.

We offer you expert worldwide support for ensuring the best possible solutions for outstanding performance. And with an extensive network of Global Service Partners, we also provide you with comprehensive global service for all of our components.

Local address:

### Hydro-Gear

[www.hydro-gear.com](http://www.hydro-gear.com)

### Daikin-Sauer-Danfoss

[www.daikin-sauer-danfoss.com](http://www.daikin-sauer-danfoss.com)

**Danfoss  
Power Solutions (US) Company**  
2800 East 13th Street  
Ames, IA 50010, USA  
Phone: +1 515 239 6000

**Danfoss  
Power Solutions GmbH & Co. OHG**  
Krokamp 35  
D-24539 Neumünster, Germany  
Phone: +49 4321 871 0

**Danfoss  
Power Solutions ApS**  
Nordborgvej 81  
DK-6430 Nordborg, Denmark  
Phone: +45 7488 2222

**Danfoss  
Power Solutions Trading  
(Shanghai) Co., Ltd.**  
Building #22, No. 1000 Jin Hai Rd  
Jin Qiao, Pudong New District  
Shanghai, China 201206  
Phone: +86 21 2080 6201

Danfoss can accept no responsibility for possible errors in catalogues, brochures and other printed material. Danfoss reserves the right to alter its products without notice. This also applies to products already on order provided that such alterations can be made without subsequent changes being necessary in specifications already agreed. All trademarks in this material are property of the respective companies. Danfoss and the Danfoss logotype are trademarks of Danfoss A/S. All rights reserved.