

Contactors for AC-1 applications  
Contacteurs pour applications AC-1  
Contactores para aplicaciones AC-1  
Schütze für AC-1 Anwendungen  
Contattori per applicazioni AC-1  
Contactores para aplicações AC-1  
AC-1 应用的接触器  
Контакторы для сфер применения AC-1

<p><b>PLEASE NOTE</b></p> <ul style="list-style-type: none"> <li>● Electrical equipment should be installed, operated, serviced, and maintained only by qualified personnel.</li> <li>● No responsibility is assumed by Schneider Electric for any consequences arising out of the use of this material.</li> </ul>	<p><b>REMARQUE IMPORTANTE</b></p> <ul style="list-style-type: none"> <li>● L'installation, l'utilisation, la réparation et la maintenance des équipements électriques doivent être assurés uniquement par du personnel qualifié.</li> <li>● Schneider Electric décline toute responsabilité quant aux conséquences de l'utilisation de ce matériel.</li> </ul>
<p><b>TENGA EN CUENTA</b></p> <ul style="list-style-type: none"> <li>● La instalación, manejo, puesta en servicio y mantenimiento de equipos eléctricos deberán ser realizados sólo por personal cualificado.</li> <li>● Schneider Electric no se hace responsable de ninguna de las consecuencias del uso de este material.</li> </ul>	<p><b>BITTE BEACHTEN</b></p> <ul style="list-style-type: none"> <li>● Elektrische Geräte dürfen nur von Fachpersonal installiert, betrieben, bedient und gewartet werden.</li> <li>● Schneider Electric haftet nicht für Schäden, die durch die Verwendung dieses Materials entstehen.</li> </ul>
<p><b>NOTA</b></p> <ul style="list-style-type: none"> <li>● Manutenzione, riparazione, installazione e uso delle apparecchiature elettriche si devono affidare solo a personale qualificato.</li> <li>● Schneider Electric non si assume alcuna responsabilità per qualsiasi conseguenza derivante dall'uso di questo materiale.</li> </ul>	<p><b>NOTA</b></p> <ul style="list-style-type: none"> <li>● A instalação, utilização e manutenção do equipamento eléctrico devem ser efectuadas exclusivamente por pessoal qualificado.</li> <li>● A Schneider Electric não assume qualquer responsabilidade pelas consequências resultantes da utilização deste material.</li> </ul>
<p><b>请注意</b></p> <ul style="list-style-type: none"> <li>● 电气设备的安装、操作、维修和维护工作仅限于合格人员执行。</li> <li>● Schneider Electric 不承担由于使用本资料所引起的任何后果。</li> </ul>	<p><b>ОБРАТИТЕ ВНИМАНИЕ</b></p> <ul style="list-style-type: none"> <li>● Установка, эксплуатация, ремонт и обслуживание электрического оборудования может выполняться только квалифицированными электриками.</li> <li>● Компания Schneider Electric не несет никакой ответственности за любые возможные последствия использования данной документации.</li> </ul>

 <p><b>DANGER / DANGER / PELIGRO / GEFAHR / PERICOLO / PERIGO / 危險 / ОПАСНОСТЬ</b></p>	
<p><b>HAZARD OF ELECTRIC SHOCK, EXPLOSION, OR ARC FLASH</b></p> <p>Disconnect all power before servicing equipment.  <b>Failure to follow these instructions will result in death or serious injury.</b></p>	<p><b>RISQUE D'ÉLECTROCUTION, D'EXPLOSION OU D'ECLAIR D'ARC ELECTRIQUE</b></p> <p>Coupez toutes les alimentations avant de travailler sur cet appareil.  <b>Si ces directives ne sont pas respectées, cela entraînera la mort ou des blessures graves.</b></p>
<p><b>PELIGRO DE DESCARGA ELÉCTRICA, EXPLOSIÓN O ARCO ELECTRICO</b></p> <p>Desconecte todas las alimentaciones antes de manipular el producto.  <b>El incumplimiento de estas instrucciones podrá causar la muerte o lesiones serias.</b></p>	<p><b>GEFAHR VON ELEKTRISCHEM SCHLAG, EXPLOSION ODER LICHTBOGEN</b></p> <p>Vor dem Arbeiten am Gerät alle Spannungsversorgungen abschalten.  <b>Die Nichtbeachtung dieser Anweisungen führt zu Tod oder schweren Verletzungen.</b></p>
<p><b>RISCHIO DI SCARICA ELETTRICA, ESPLOSIONE O ARCO ELETTRICO</b></p> <p>Scollegare l'apparecchio da tutti i circuiti di alimentazione prima di qualsiasi intervento.  <b>Il mancato rispetto di queste istruzioni provocherà morte o gravi infortuni.</b></p>	<p><b>RISCO DE ELECTROCUSSÃO, DE EXPLOÇÃO, OU DE ARCO ELÉCTRICO</b></p> <p>Desconecte todas as alimentações antes de manipular o produto.  <b>A não observância destas instruções resultará em morte, ou ferimentos graves.</b></p>
<p><b>电击、爆炸或电弧闪光危险</b></p> <p>在此电力设备上工作时,请先切断所有电源  <b>不遵循上述说明将导致人员伤亡。</b></p>	<p><b>ОПАСНОСТЬ ПОРАЖЕНИЯ ЭЛЕКТРИЧЕСКИМ ОКОМ, ВЗРЫВА ИЛИ ВСПЫШКИДУГИ</b></p> <p>Перед обслуживанием или ремонтом убедитесь, что питание отключено.  <b>Несоблюдение этих инструкций приведет к смерти или серьезной травме.</b></p>

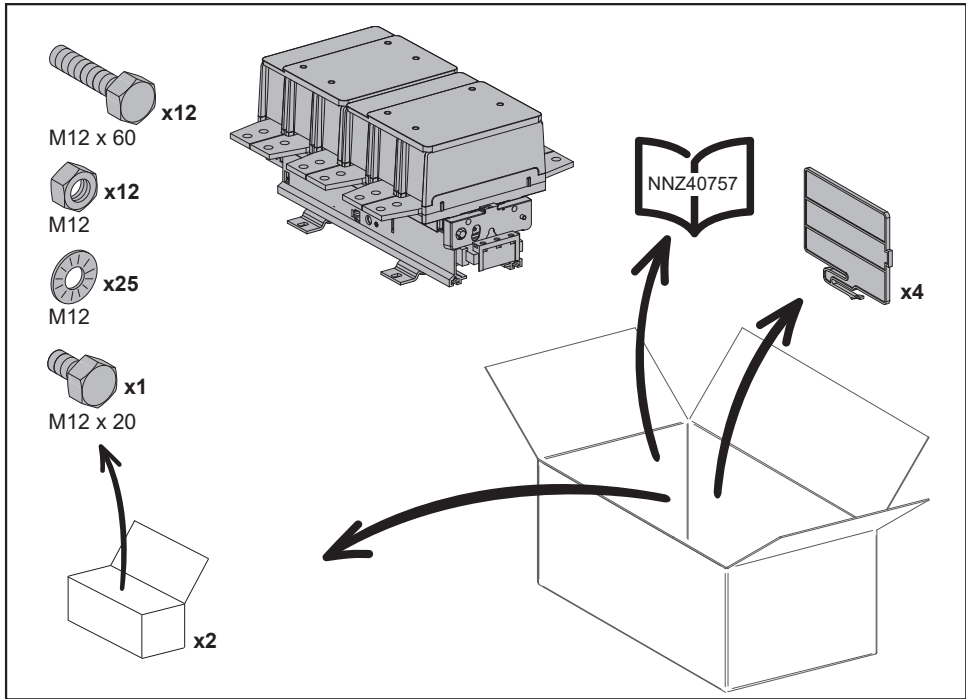

# A

<ul style="list-style-type: none"> <li>■ Ue max. 1140 V~</li> <li>■ f = 50-60 Hz</li> <li>■ AC-1</li> <li>■ 36 kg / 79.3 lb</li> </ul>		<table border="1" style="width: 100%; border-collapse: collapse;"> <thead> <tr> <th style="text-align: center;"><math>I_{th}</math></th> <th style="text-align: center;"><math>T^{\circ}</math></th> </tr> </thead> <tbody> <tr> <td style="text-align: center;">2600 A (LC1F2600L S410/S411+ LA9F2600)</td> <td style="text-align: center;"> <math>\leq 60^{\circ}C</math>  <math>\leq 140^{\circ}F</math> </td> </tr> </tbody> </table>	$I_{th}$	$T^{\circ}$	2600 A (LC1F2600L S410/S411+ LA9F2600)	$\leq 60^{\circ}C$ $\leq 140^{\circ}F$
$I_{th}$	$T^{\circ}$					
2600 A (LC1F2600L S410/S411+ LA9F2600)	$\leq 60^{\circ}C$ $\leq 140^{\circ}F$					

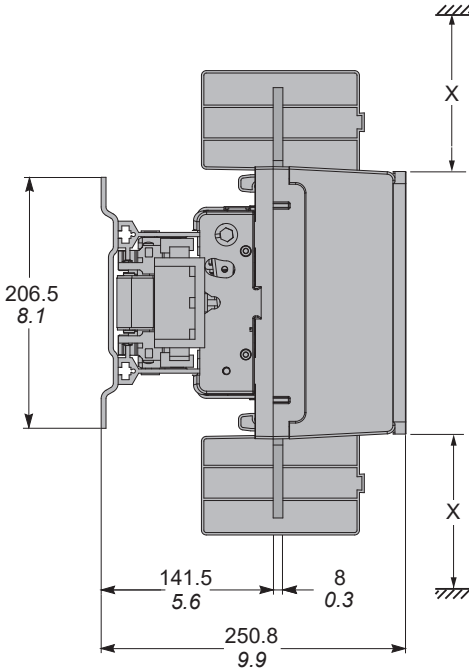
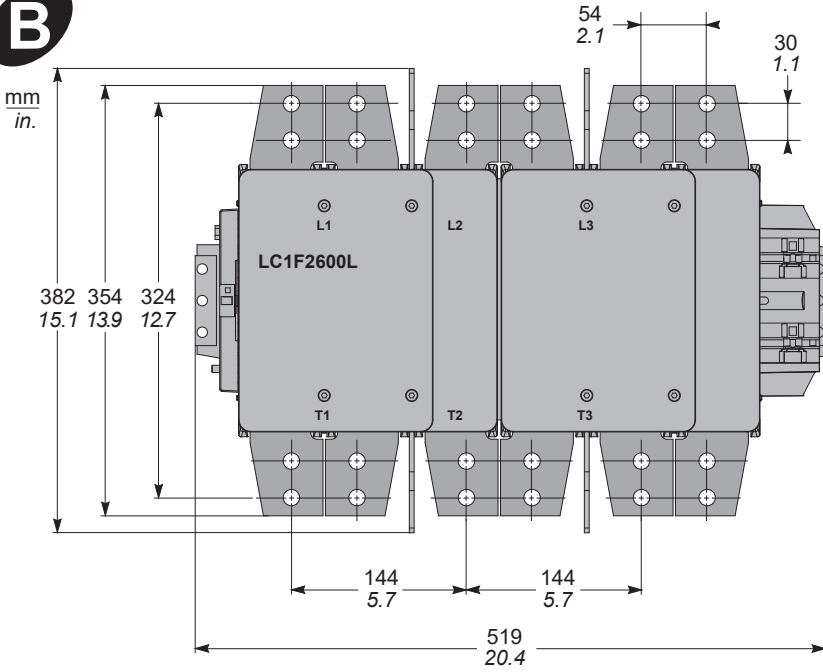
**B**

$X \left( \frac{\text{mm}}{\text{in.}} \right)$	$U_e \text{ (V)}$
$\geq 90$ $\geq 3.5$	$\leq 500$
$\geq 100$ $\geq 3.9$	$\leq 1140$

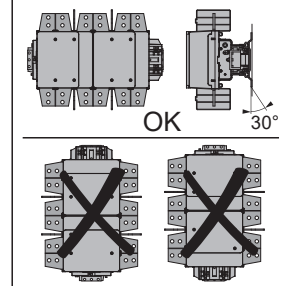
**i**



mm  
in.

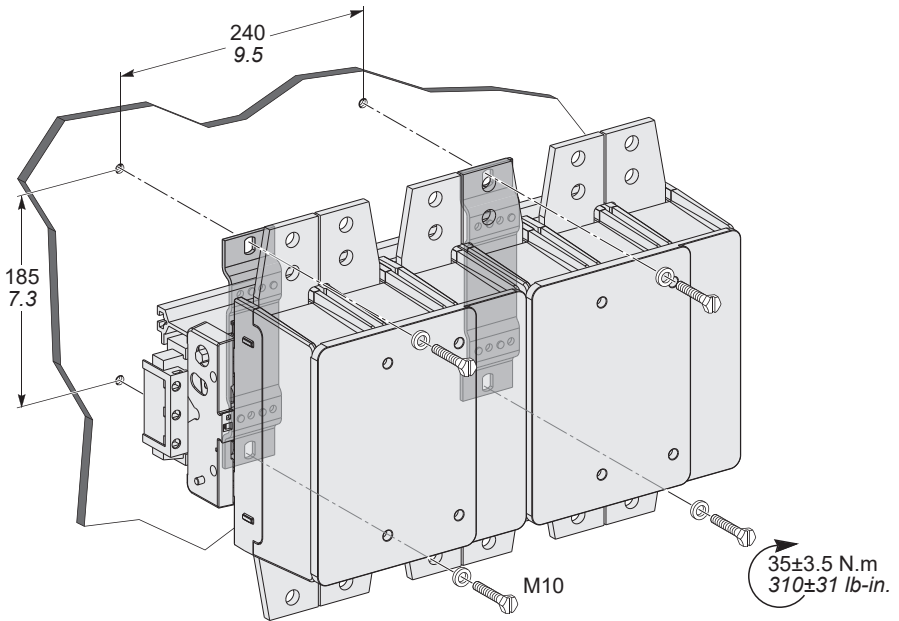
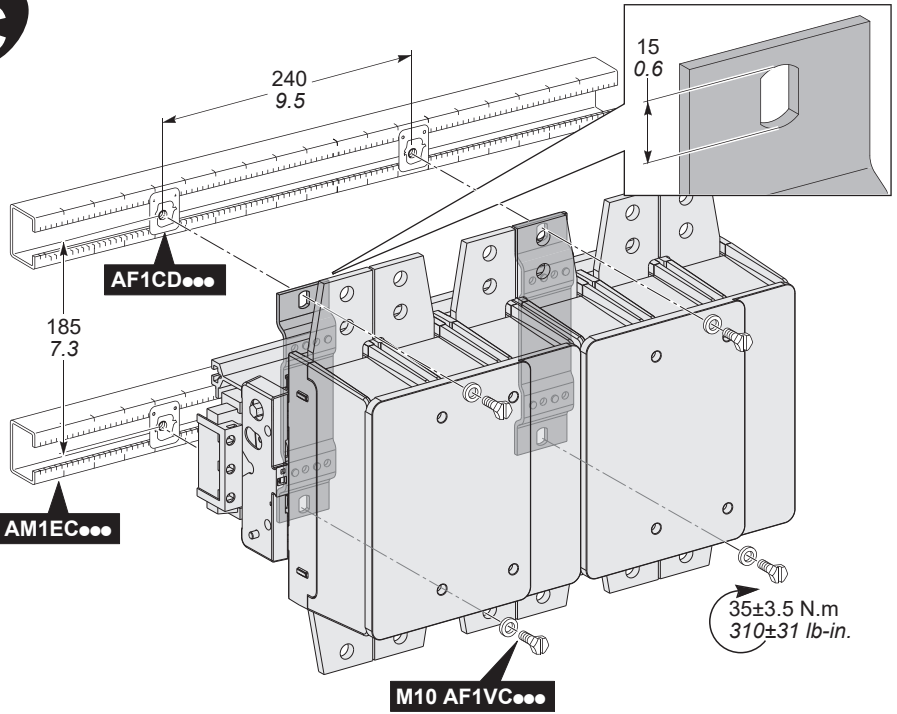



# LC1F2600L + LA9F2600

## LA9F2600

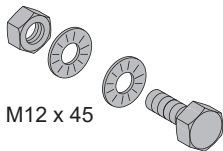

M12 x 45

x24

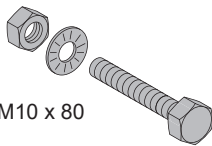

M10 x 80

x24

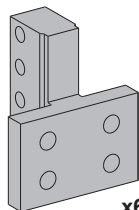

x6

LA9F2600 not supplied; to be ordered separately  
LA9F2600 non fourni, à commander séparément.  
LA9F2600 no suministrado (se solicita por separado).  
LA9F2600 nicht im Lieferumfang enthalten; separat zu bestellen.  
LA9F2600 non fornito, da ordinare separatamente.  
LA9F2600 não fornecido, deve ser encomendado separadamente.  
未提供 LA9F2600, 请单独订购  
LA9F2600 не поставляется; его требуется заказывать отдельно

mm  
in.

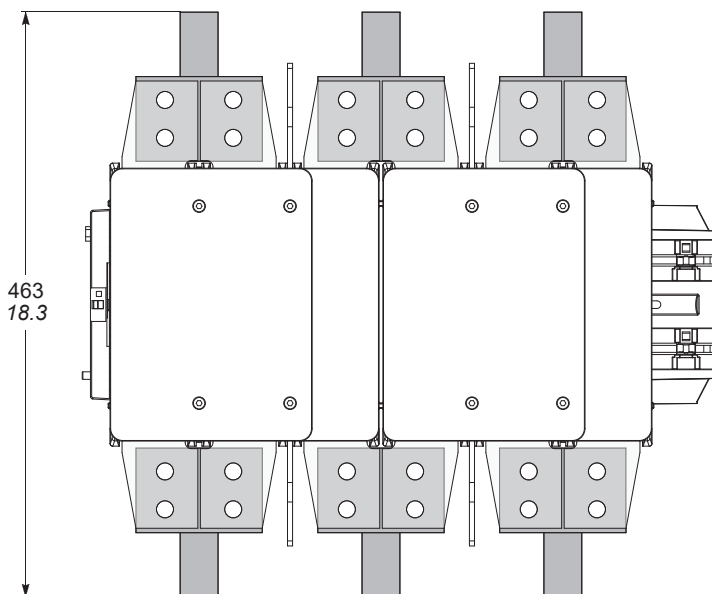
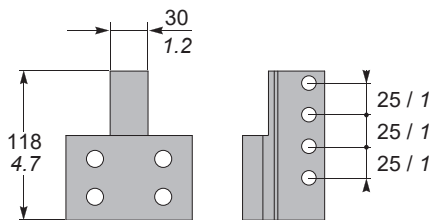



# LC1F2600L + LA9F2600

mm  
in.

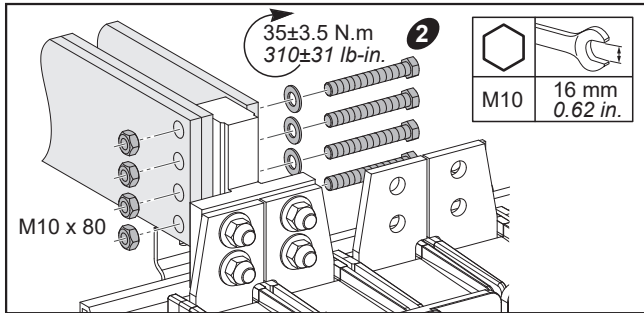
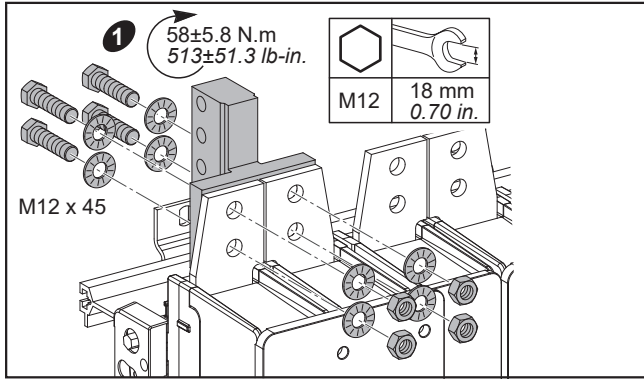

mm  
in.

GB/T

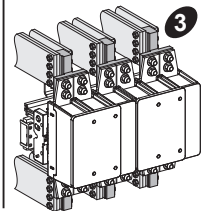
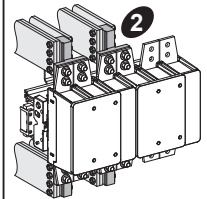
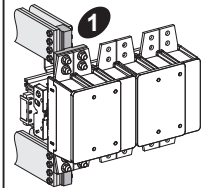
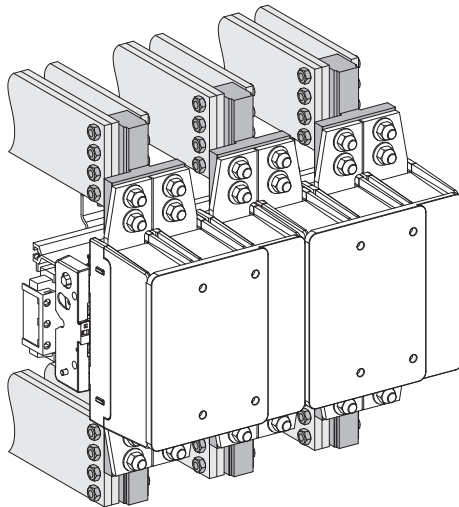
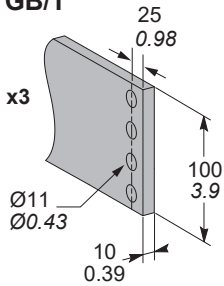

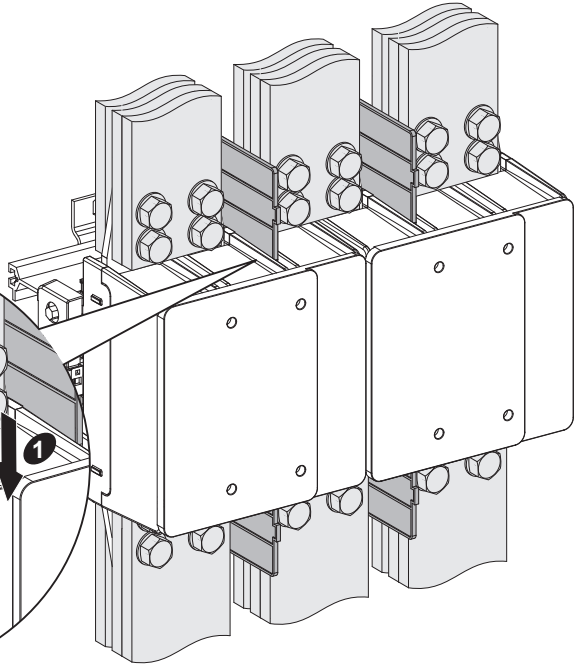
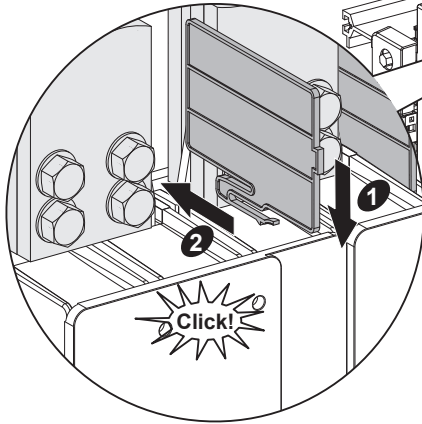
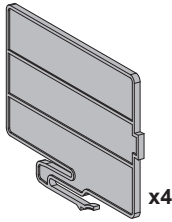
**E**

## **DANGER / DANGER / PELIGRO / GEFAHR / PERICOLO / PERIGO / 危險 / ОПАСНОСТЬ**

### **HAZARD OF ELECTRIC SHOCK, EXPLOSION, OR ARC FLASH**

Always install inter phase barriers when mounting the contactor.

**Failure to follow these instructions will result in death or serious injury.**

### **RISQUE D'ÉLECTROCUTION, D'EXPLOSION OU D'ECLAIR D'ARC ELECTRIQUE**

Installez les séparateurs de phase dans tous les cas de montage du contacteur.

**Si ces directives ne sont pas respectées, cela entraînera la mort ou des blessures graves.**

### **PELIGRO DE DESCARGA ELÉCTRICA, EXPLOSIÓN O ARCO ELECTRICO**

Instale siempre los separadores de fases durante el montaje del contactor.

**El incumplimiento de estas instrucciones podrá causar la muerte o lesiones serias.**

### **GEFAHR VON ELEKTRISCHEM SCHLAG, EXPLOSION ODER LICHTBOGEN**

Bei der Montage des Schützes grundsätzlich Phasentrenner installieren.

**Die Nichtbeachtung dieser Anweisungen führt zu Tod oder schweren Verletzungen.**

### **RISCHIO DI SCARICA ELETTRICA, ESPLOSIONE O ARCO ELETTRICO**

Installare i separatori di fase in tutti i casi di montaggio del contactor.

**Il mancato rispetto di queste istruzioni provocherà morte o gravi infortuni.**

### **RISCO DE ELECTROCUSSÃO, DE EXPLOÇÃO, OU DE ARCO ELÉCTRICO**

Instale os separadores de fase em todos os casos de montagem do contactor.

**A não observância destas instruções resultará em morte, ou ferimentos graves.**

### **电击、爆炸或弧闪的危險**

在安装接触器时，一定要安装相间隔板。

**不遵循上述说明将导致人员伤亡。**

### **ОПАСНОСТЬ ПОРАЖЕНИЯ ЭЛЕКТРИЧЕСКИМ ТОКОМ, ВЗРЫВА ИЛИ ВСПЫШКИДУГИ**

При монтаже контактора всегда устанавливайте межфазные ограждения.

**Несоблюдение этих инструкций приведет к смерти или серьезной травме.**



**F**

M12



M12 x 20

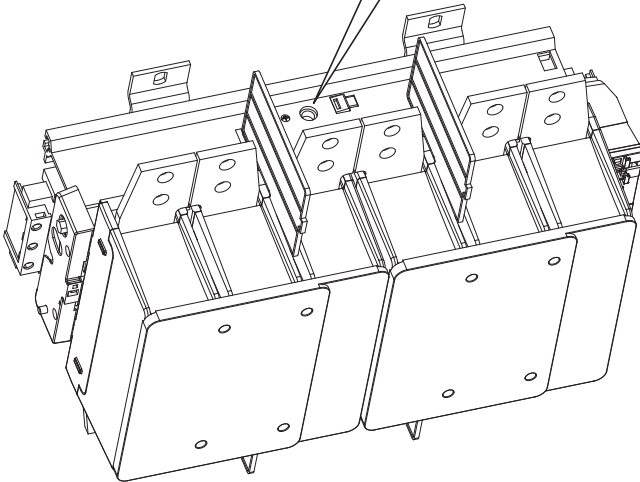
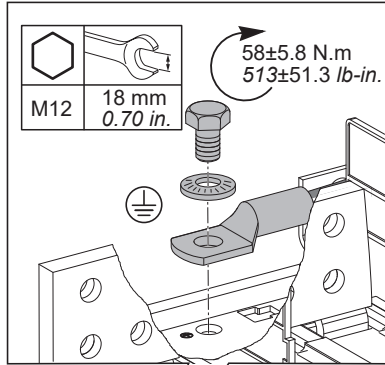

**G**

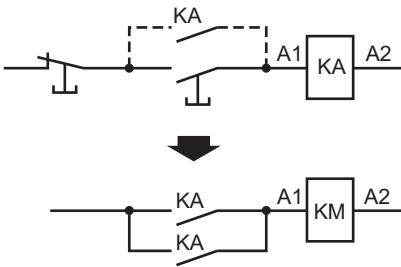
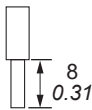
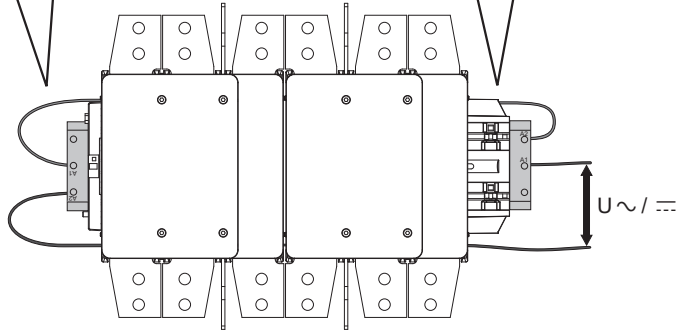
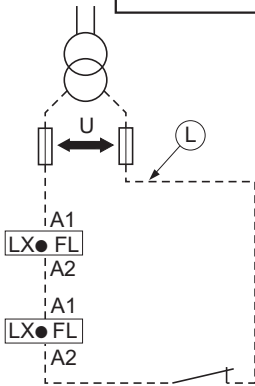
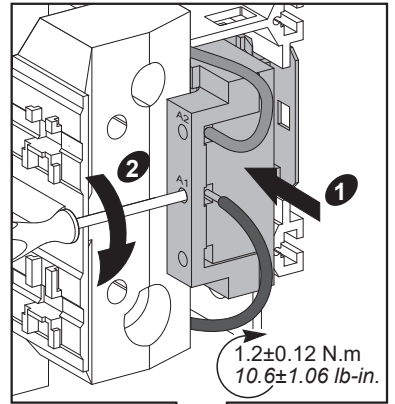
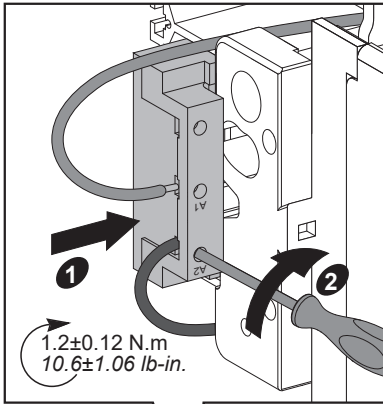

U	(L) m ft	mm <sup>2</sup> AWG	
220 V~	15 49.2	1 16	
	20 65.6	1.5 16	
220 V ∞	40 131.2	2.5 12	
	60 197	4 12	

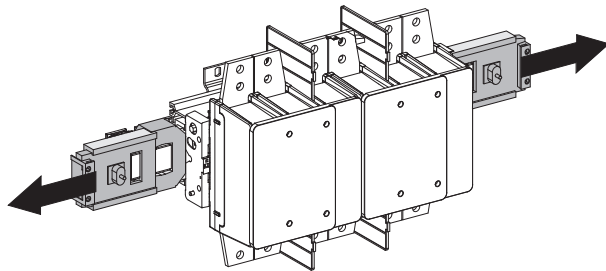

**DANGER / DANGER / PELIGRO / GEFAHR /  
PERICOLO / PERIGO / 危险 / ОПАСНОСТЬ**

**HAZARD OF ELECTRIC SHOCK, EXPLOSION, OR  
ARC FLASH**

Disconnect all power before servicing equipment.  
**Failure to follow these instructions will result in  
death or serious injury.**

**RISQUE D'ÉLECTROCUTION, D'EXPLOSION OU  
D'ECLAIR D'ARC ELECTRIQUE**

Coupez toutes les alimentations avant de travailler sur  
cet appareil.  
**Si ces directives ne sont pas respectées, cela  
entraînera la mort ou des blessures graves.**

**PELIGRO DE DESCARGA ELÉCTRICA, EXPLOSIÓN  
O ARCO ELECTRICO**

Desconecte todas las alimentaciones antes de  
manipular el producto.  
**El incumplimiento de estas instrucciones podrá  
causar la muerte o lesiones serias.**

**GEFAHR VON ELEKTRISCHEM SCHLAG,  
EXPLOSION ODER LICHTBOGEN**

Vor dem Arbeiten am Gerät alle  
Spannungsversorgungen abschalten.  
**Die Nichtbeachtung dieser Anweisungen führt zu  
Tod oder schweren Verletzungen.**

**RISCHIO DI SCARICA ELETTRICA, ESPLOSIONE O  
ARCO ELETTRICO**

Scollegare l'apparecchio da tutti i circuiti di  
alimentazione prima di qualsiasi intervento.  
**Il mancato rispetto di queste istruzioni provocherà  
morte o gravi infortuni.**

**RISCO DE ELECTROCUSSÃO, DE EXPLOÇÃO, OU  
DE ARCO ELÉCTRICO**

Desconecte todas as alimentações antes de manipular  
o produto.  
**A não observância destas instruções resultará em  
morte, ou ferimentos graves.**

**电击、爆炸或弧闪的危险**

在此电力设备上工作时,请先切断所有电源  
不遵循上述说明将导致人员伤亡。

**ОПАСНОСТЬ ПОРАЖЕНИЯ ЭЛЕКТРИЧЕСКИМ  
ОКОМ, ВЗРЫВА ИЛИ ВСПЫШКИДУГИ**

Перед обслуживанием или ремонтом убедитесь,  
что питание отключено.  
**Несоблюдение этих инструкций приведет к  
смерти или серьезной травме.**

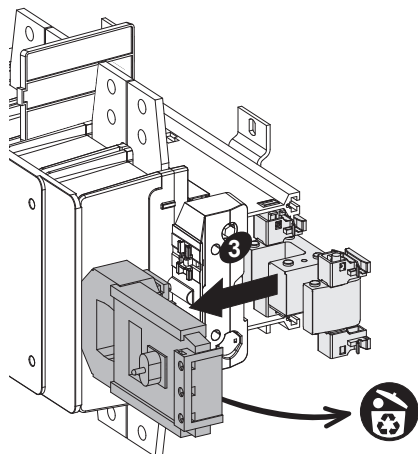
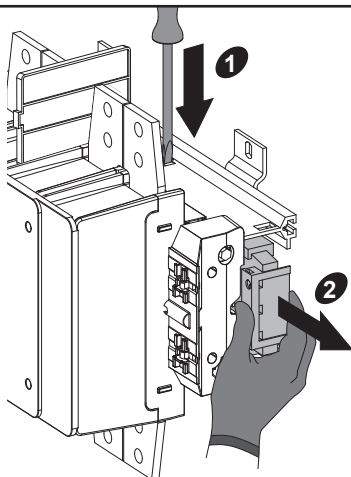



Reference for replacement coils  
 Referencia de las bobinas de repuesto  
 Codice di riferimento delle bobine di ricambio  
 替换线圈参考



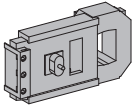

Référence des bobines de rechange  
 Bestellnummer der Ersatzspulen  
 Referências das bobinas sobressalentes  
 Справка для сменных катушек

LX1 FL●●●

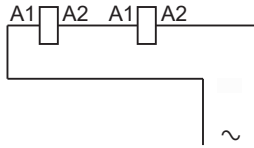

x2







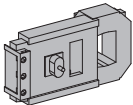

U ~					
230 V	2 x LX1 FL110	2200 ↑ 2700	37.4 ↑ 50.6	8 A	8 A

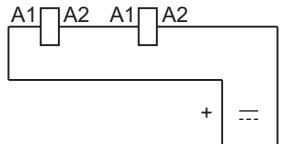
LX4 FL●●●



x2



U =					
220 V	2 x LX4 FL110	2130 ↑ 2880	13 ↑ 25	8 A	8 A

**J**

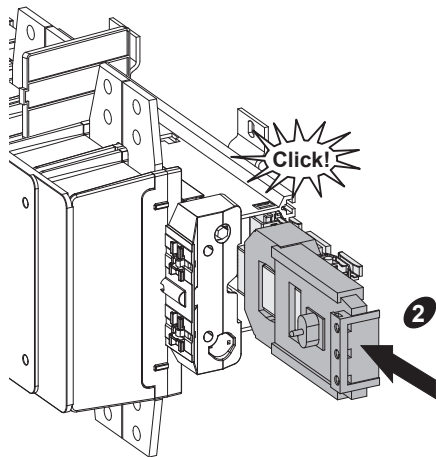
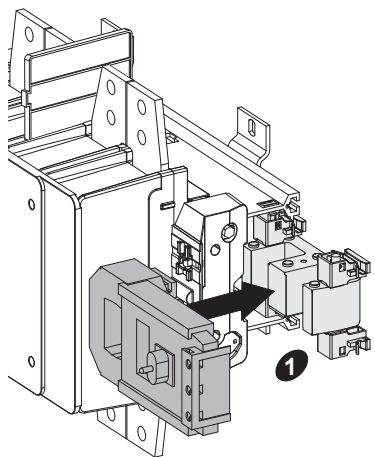

LX1 FL ●●●  
LX4 FL ●●●

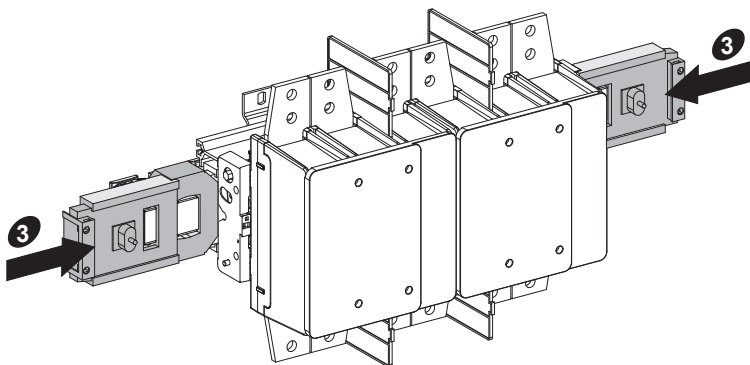

**K**

Arc chamber replacement  
 Sustitución de la cámara de arqueo  
 Camera d'arco sostitutiva  
 电弧室更换

Remplacement des boîtiers de soufflage d'arc  
 Austausch der Lichtbogenkammern  
 Substituição da câmara em arco  
 Замена дуговой камеры

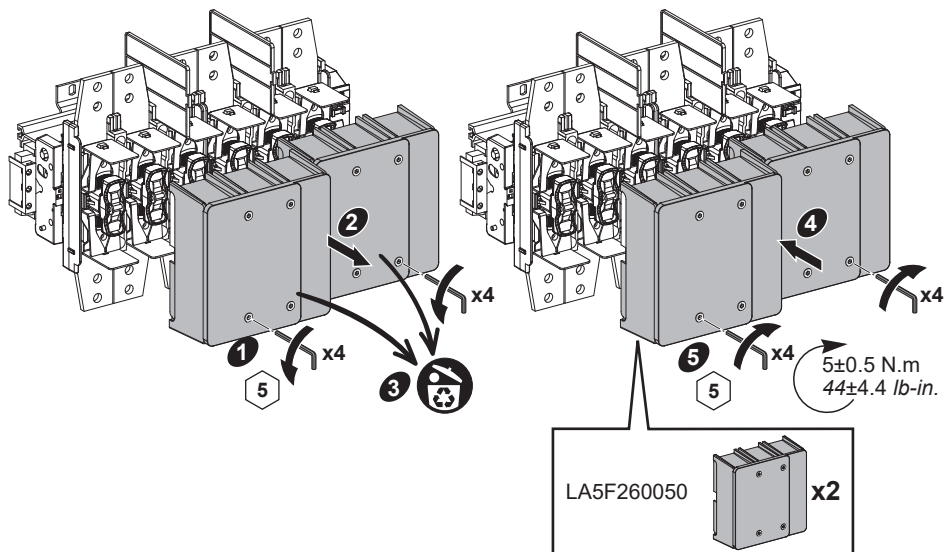

The blackening of the contacts and the arc-boxes is a natural consequence which occurs during normal operation, and does not affect the functioning of the product.

Le noircissement des contacts et des boîtiers d'arc est un phénomène naturel qui n'altère pas le fonctionnement de l'appareil.

El ennegrecimiento de los contactos y de las cámaras de arco es un fenómeno natural que no altera el funcionamiento del aparato.

Die Schwärzung an den Kontakten und in der Lichtbogenkammer ist ein normales Phänomen und hat keine Auswirkungen auf die Funktionsweise des Gerätes.











L'annerimento dei contatti e delle camere spegni-arco è un fenomeno naturale che non altera il funzionamento del l'apparecchio.

O escurecimento dos contatos e das caixas de arco é uma consequência natural que ocorre durante a operação normal e não afeta o funcionamento do produto.

触点和电弧室变黑 属正常操作中的 正常现象,对产品运行 无任何影响。

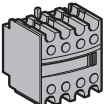
Почернение контактов и корпусов дуги является естественным последствием нормальной работы и не влияет на функционирование изделия.

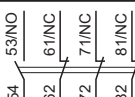
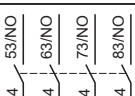
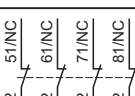

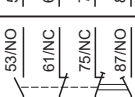
	<b>LA DN10</b>		NO
	<b>LA DN01</b>		NC
	<b>LA DN11</b>		1 NO + 1 NC
	<b>LA DN20</b>		2 NO
	<b>LA DN02</b>		2 NC
	<b>LA DN22</b>		2 NO + 2 NC
	<b>LA DN13</b>		1 NO + 3 NC
	<b>LA DN40</b>		4 NO
	<b>LA DN04</b>		4 NC
	<b>LA DN31</b>		3 NO + 1 NC
	<b>LA DC22</b>		2 NO + 2 NC

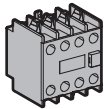

<b>LADN116S207C (1)</b>		1 NO + 1 NC
<b>LADN206S207C (1)</b>		2 NO
<b>LADN226S207C (1)</b>		1 NC + 2 NO + 1 NC
<b>LADN316S207C (1)</b>		3 NO + 1 NC
<b>LADN406S207C (1)</b>		4 NO

(1) LADN●●●S207C

For wind application

Pour application en milieu venteux

Para aplicación eólica

Für Windanwendungen



Per applicazione eolica

Para aplicação eólica

风电专用

Для ветровых установок

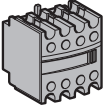
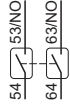
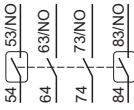
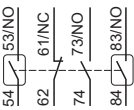
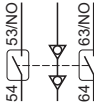
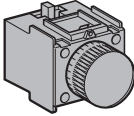
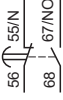

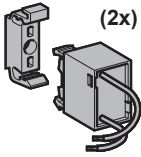
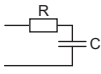
	<b>LA1 DX20 (2)</b>		2 NO
	<b>LA1 DZ40 (2)</b>		2 NO + 2 NO
	<b>LA1 DZ31 (2)</b>		1 NO + 1 NC + 2 NO
	<b>LA1 DY20 (2)</b>		2 NO
	<b>LA DT0 LA DT2 LA DS2 LA DT4</b>		On-delay 1 NO + 1 NC
	<b>LA DR0 LA DR2 LA DR4</b>		Off-delay 1 NO + 1 NC
 (2x)	<b>LA4 FRCE LA4 FRCF LA4 FRCP LA4 FRCV LA9 D09981</b>		Coil suppressor blocks (1 per coil)

(2) LA1 DX/DY/DZ

Sealed contacts for harsh environment.

Contacts étanches pour environnement sévère.

Contactos estancos para entornos severos.

Versiegelte Kontakte für extreme Umgebungsbedingungen.

Contatti a tenuta stagna per ambienti difficili.

Contactos estanques para ambiente severo.

密封触点 适合恶劣环境。

Герметизированные контакты Для жестких условий внешней среды.

**N**

LA DN 11  
20  
02

LA D●

LA D●

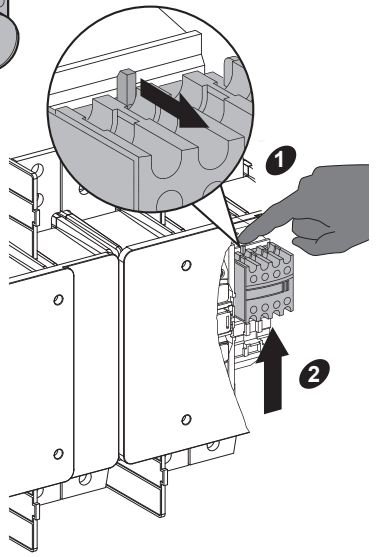
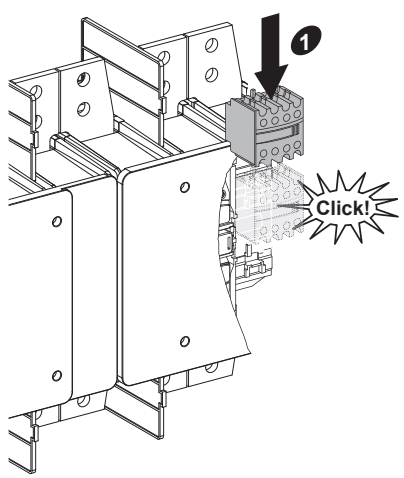

LA DN 01  
10

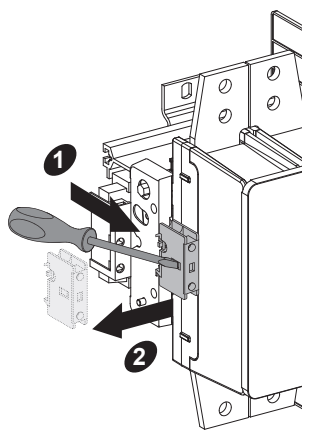
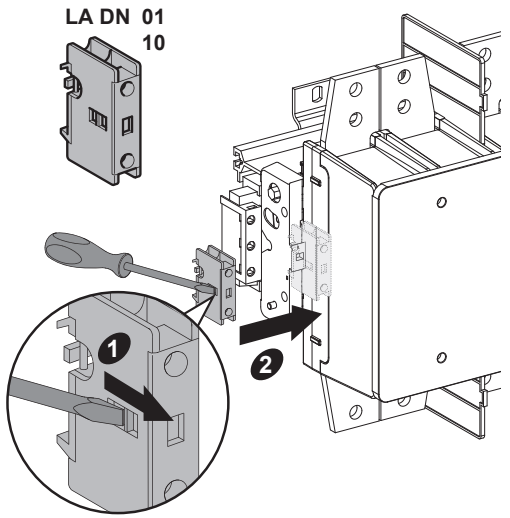

**O**

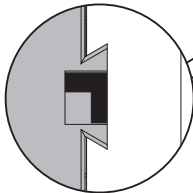
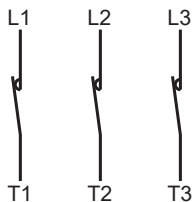
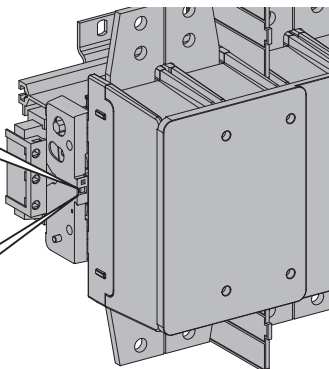
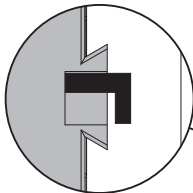
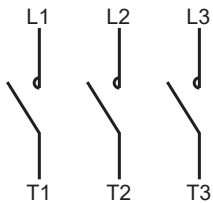

**P**

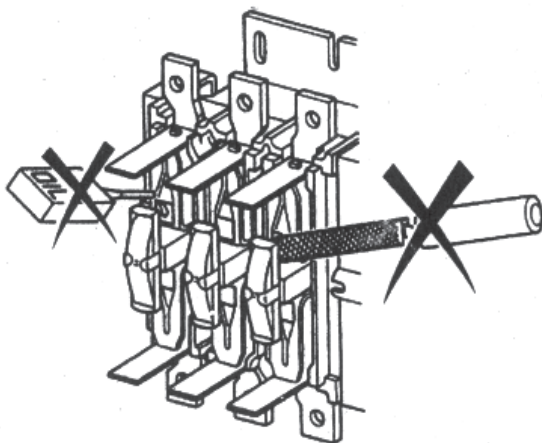
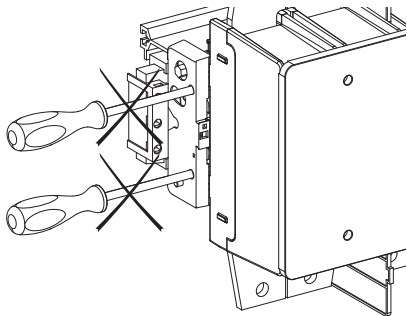
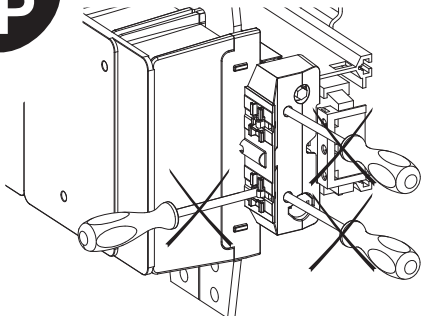



<p>The product's manufacture date is coded PYYYWWD, where:</p> <ul style="list-style-type: none"> <li>● PP: plant code</li> <li>● YY: year of manufacture</li> <li>● WW: week of manufacture</li> <li>● (D: weekday of manufacture (Monday = 1))</li> </ul>	<p>La date de fabrication du produit est codée PYYYWWD, avec:</p> <ul style="list-style-type: none"> <li>● PP: code usine</li> <li>● YY: année de fabrication</li> <li>● WW: semaine de fabrication</li> <li>● (D: jour de fabrication dans la semaine (lundi = 1))</li> </ul>	<p>La fecha de fabricación del producto está codificada PYYYWWD, donde:</p> <ul style="list-style-type: none"> <li>● PP: código de la planta</li> <li>● YY: año de fabricación</li> <li>● WW: semana de fabricación</li> <li>● (D: día de la semana de fabricación (lunes = 1))</li> </ul>	<p>Das Herstellungsdatum des Produkts ist folgendemmaßen codiert: PYYYWWD. Wobei:</p> <ul style="list-style-type: none"> <li>● PP: Werkscode</li> <li>● YY: Herstellungsjahr</li> <li>● WW: Herstellungswoche</li> <li>● (D: Herstellungstag (Montag = 1))</li> </ul>
<p>La data di fabbricazione del prodotto è indicata con il codice PYYYWWD, dove:</p> <ul style="list-style-type: none"> <li>● PP: codice stabilimento</li> <li>● YY: anno di fabbricazione</li> <li>● WW: settimana di fabbricazione</li> <li>● (D: giorno della settimana in cui il prodotto è stato fabbricato (lunedì = 1))</li> </ul>	<p>A data de fabrico do produto está sob a forma de código PYYYWWD, onde:</p> <ul style="list-style-type: none"> <li>● PP: código da fábrica</li> <li>● YY: ano de fabrico</li> <li>● WW: semana de fabrico</li> <li>● (D: dia da semana de fabrico (Segunda-feira = 1))</li> </ul>	<p>产品制造日期采用如下代码 PYYYWWD, 其中:</p> <ul style="list-style-type: none"> <li>● PP: 工厂代码</li> <li>● YY: 制造年份</li> <li>● WW: 第几周制造</li> <li>● (D: 星期几制造 (星期一 = 1))</li> </ul>	<p>Дата производства продукта закодирована в формате PYYYWWD, где:</p> <ul style="list-style-type: none"> <li>● PP: код завода</li> <li>● YY: год производства</li> <li>● WW: неделя производства</li> <li>● (D: день недели, когда был произведен продукт (понедельник = 1))</li> </ul>

产品中有毒有害物质或元素的名称及含量  
Contents of Toxic or Hazardous Substances or Elements

部件名称 Part Name	有毒有害物质或元素 Toxic or hazardous Substances and Elements					
	铅 (Pb)	汞 (Hg)	镉 (Cd)	六价铬 (Cr <sup>6+</sup> )	多溴联苯 (PBB)	多溴二苯醚 (PBDE)
金属部件 Metal Parts	X	O	O	O	O	O

**O** : 表示该有毒有害物质在该部件所有均质材料中的含量均在 SJ/T11363-2006 标准规定的限量要求以下。  
Indicates that this toxic or hazardous substance contained in all of the homogeneous materials for this part is below the limit requirement in SJ/T11363-2006.

**X** : 表示该有毒有害物质至少在该部件的某一均质材料中的含量超出 SJ/T11363-2006 标准规定的限量要求。  
Indicates that this toxic or hazardous substance contained in at least one of the homogeneous materials used for this part is above the limit requirement in SJ/T11363-2006.

对销售之日的所售产品,本表显示,施耐德电气供应链的电子产品信息可能包含这些物质。  
注意:在所售产品中可能会也可能不会含有所有列出的部件。  
Note: The products on sale may or may not contain all the parts/components listed here.



B Q T 5 1 4 5 0

**Schneider Electric Industries SAS**

35, rue Joseph Monier  
CS30323  
F - 92500 Rueil-Malmaison  
www.se.com