

From Centralized Power Generation to a Distributed model

Breakers, Switches & Fusegear for Utility

Introduction

The Electricity Market today is facing a transformation mainly driven by an increasing energy demand. Megatrends as, population growth, urbanization, and electrification of rural areas but also increasing focuses on environmental protection, are influencing the current structure of the Industry. In this macro scenario, new technological trends and R&D investments are playing a central role, leading the major sector's changes; growth of distributed power generation, increasing usage of Renewables energies, Energy efficiency, Demand side management and Smart grids, head the list of technologies expected to have the biggest impact on the power business.

ABB as manufacturer and supplier has been working for many years to offer products and solutions to support Utilities to improve their performance and reduce the environmental impact of energy systems, the focus of ABB research is fixed on developing efficient, sustainable ways to generate, transmit, distribute and use electrical energy. With a large experience in Automation & Distribution Products, ABB offers a range of products, systems and services to help customers increase power capacity enhance grid reliability, improve energy efficiency and lower environmental impact.

From Centralized Power Generation → to a Distributed model (Smart Grid)

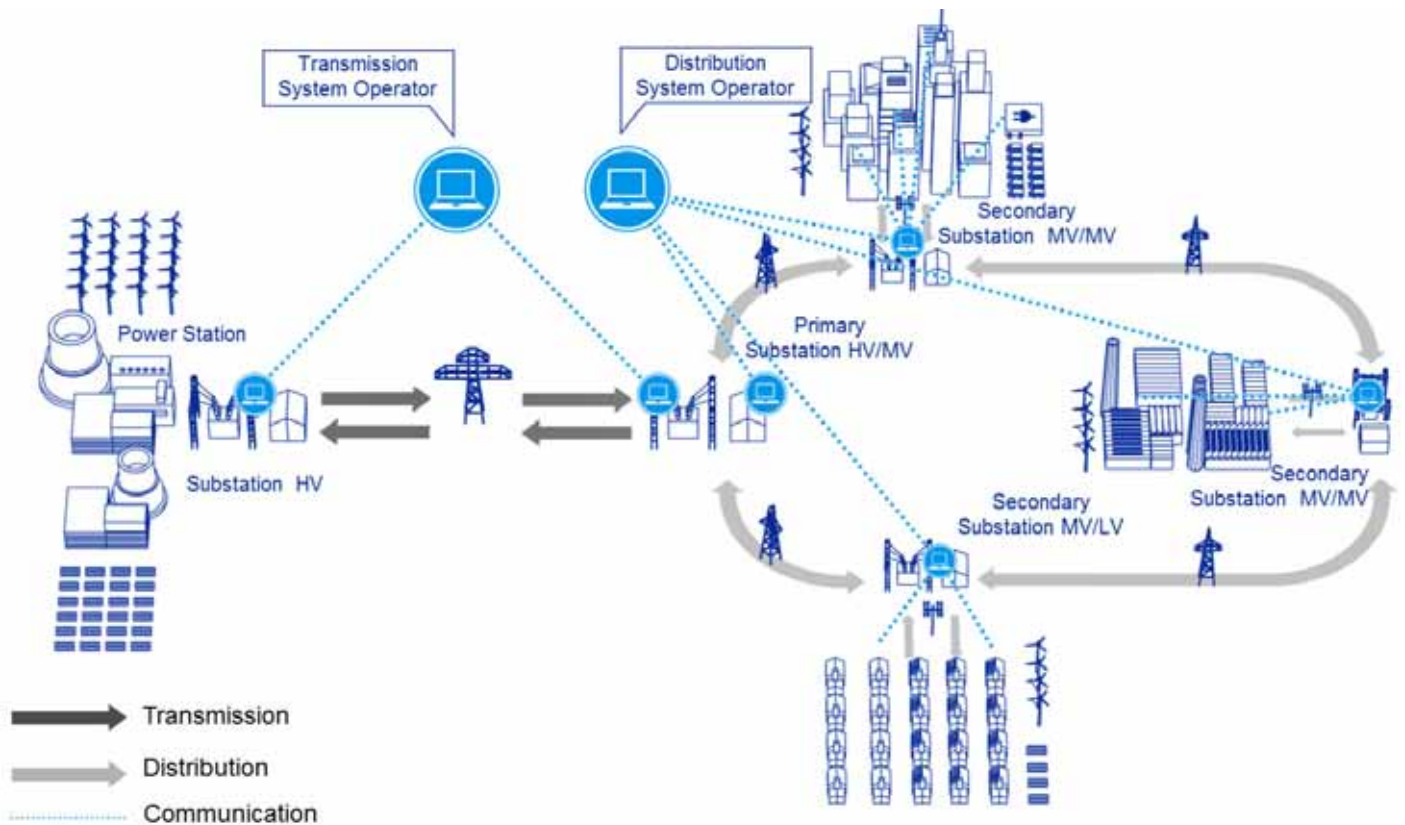

Changes in Industry Structure

Today new market forces are impacting the landscape of utilities around the world; growth of renewable energies with distributed generation, environmental concerns, and increased expectations on operational efficiency and energy management, are the main drivers requiring the transformation of industry business models. The existing grids are under pressure to deliver the growing demand for power, as well as provide a stable and sustainable supply of electricity; these complex challenges are driving the evolution of utility sector, supporting the development of Smart Grid. Smart Grids are electrical power grids that are more efficient and more resilient, therefore, “smarter” than our current power grids.

Smart grids will provide more electricity to meet rising demand, increase reliability and quality of power supplies, integrating low carbon energy sources into power networks. Smart grids possess demand response capacity to help balance electrical consumption with supply, as well as the potential to integrate new technologies to enable energy storage devices and the large-scale use of electric vehicles. Electrical systems will undergo a major evolution, improving reliability and reducing electrical losses, capital expenditures and maintenance costs. A smarter grid will provide greater control over energy costs and a more reliable energy supply for consumers.

ABB Offer: Breakers, Switches & Fusegears

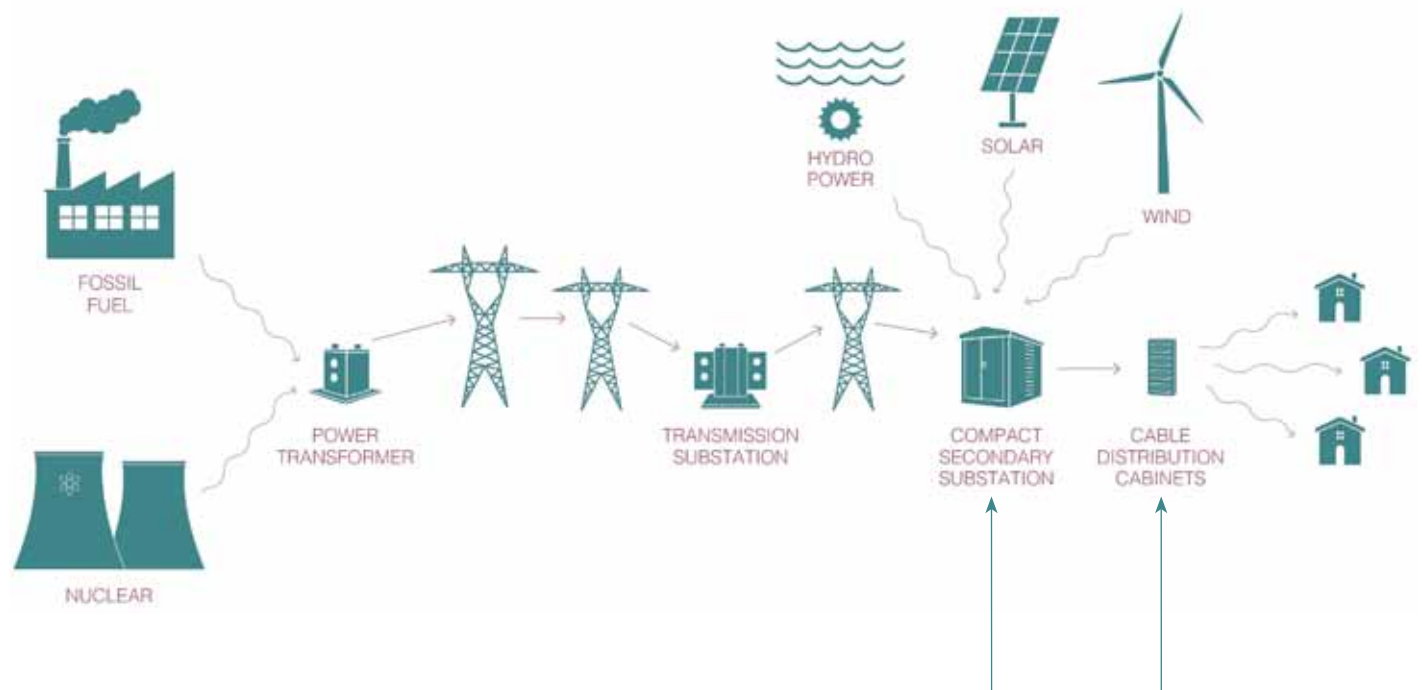

Switches



ACBs



MCCBs



Fusegears



CDC

Breakers, Switches & Fusegear for Utility

The Application - Compact Secondary Substation (CSS)

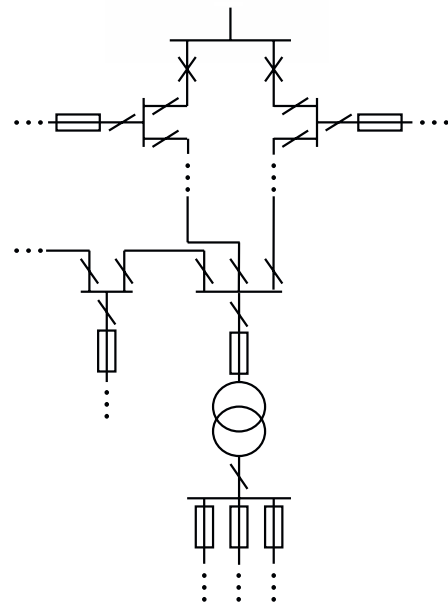

CSS Definition

Prefabricated substations are defined as a type-tested assembly comprising an enclosure containing **medium-voltage switchgear, transformer, low-voltage switchboard** connections and auxiliary equipment to supply low-voltage energy from a medium voltage system or vice versa. These substations are in locations accessible to the public and should ensure protection to persons according to the specified service conditions, ref. IEC62271-202.

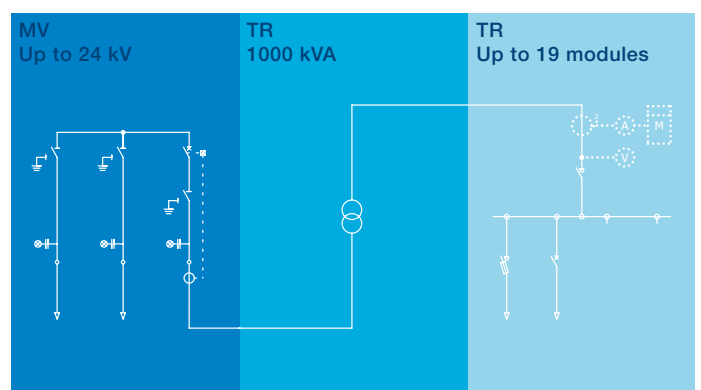

From Medium Voltage to Low Voltage

Low Voltage Panel

A typical CSS LV Switchboard consisting of Incoming feeder connected to Distribution Transformer and Outgoing feeders for Cable Distribution Cabinets, or directly to end users, depending on local specification from utility companies and national standards. The equipment used in low-voltage panels can be different from country to country, utility to utility.



Grid Topology

Outgoing feeders for Cable Distribution Cabinets

Typical 630A or 400A units, feeding one CDC (cable Distribution Cabinet)



Outgoing feeders directly to end users



Breakers, Switches & Fusegear for Utility

The Application - Compact Secondary Substation (CSS)

Value Proposition

Current changes in the Utility industry must be supported by technological development. ABB as one of the world's leading engineering companies is focusing on innovation and R&D investment, to develop new products and innovative solutions,

supporting customers to use electrical power efficiently, and improving Utility's performance. ABB with its broad product portfolio and wide know how in Low Voltage distribution is supporting utilities in smart grid future development, according to the electricity requirements of our global society: **reliability, efficiency** and **sustainability**.

BU Breakers & Switches Offer for Compact Secondary Substation

	Definition	Applicable ABB Products	ABB Breakers & Switches Benefit
Reliability	Providing high quality electrical energy whenever it's needed	Incoming Unit: <ul style="list-style-type: none"> • Load Break Switch (OT series) • Moulded Case Circuit Breaker (Tmax) • Air Circuit Breaker (Emax) • Fuse switch disconnecter (in Line/Kabeldon) 	<ul style="list-style-type: none"> • Emax 2 integrated disturbance analyzer to improve the reliability providing detailed and real-time information on the conditions in the grid • Emax 2 enhanced communication capabilities for easy integration with supervision and monitoring system • Tmax range redefines size to performance ratios ensuring space saving for cabling operation and easy installation
Efficiency	Increasing the efficiency of power generation and reducing losses in transmission distribution and consumption of electrical energy.	Outgoing Unit: <ul style="list-style-type: none"> • Moulded Case Circuit Breaker (Tmax) • Fuse switch disconnecter (in Line/Kabeldon) 	<ul style="list-style-type: none"> • Tmax circuit breakers modular accessories to increase flexibility and fast installation • In Line fusegear offer a high level of personal safety with a robust construction that is maintenance free and is designed for intelligent communication to support a high level of stability in the electrical distribution network • Kabeldon fusegear system consists of a unique, screen protected (IP2X) busbar system which is combined with a broad range of switching devices and connectors
Sustainability	Ensuring the effective integration of renewable power generation		<ul style="list-style-type: none"> • OT switch fuse disconnecter offer high performances with reduce overall dimensions

Breakers, Switches & Fusegear for Utility

ABB Product Portfolio

Emax 2 - Air Circuit Breakers



General

Emax 2 family is available as complete range air circuit breakers up to 6300A. All the circuit-breakers, both three-pole and four-pole, are available in the fixed and withdrawable versions. All Emax 2 circuit breakers share the same accessories and the same trip units along all the four physical frame sizes.

Outstanding performance

The SACE Emax 2 enables switchgear of compact dimensions and high ratings to be built with busbars of reduced length and cross-section. The rating levels are updated and uniform throughout the sizes to meet the demands and needs of today's installations, from 42kA to 200kA, and to standardize switchgear projects. High short-time currents, together with the efficiency of the protection functions, guarantee complete selectivity in all situations.

Accurate design and choice of materials enables optimization of the overall dimensions of the circuit-breaker. In this way switchgear of compact dimensions can be built and outstanding savings at the same performance can be obtained.

Remote Control and Supervision

Emax 2 circuit-breakers can be equipped with communication units available for use with Modbus, Profibus, and DeviceNet protocols as well as the modern Modbus TCP, Profinet and EtherNet IP protocols. Furthermore, the integrated IEC61850 communication module enables connection to the Substation Automation world.

Installation

Double insulation between the front of the switchgear and the live parts is granted to ensure operation in complete safety. The circuit-breakers can be powered indifferently from above or below. All essential information is available in the central area of the front shield and enables immediate identification of the status of the circuit-breaker: open, closed, ready to close, charged and discharged springs. Maintenance is simply and safe: the main accessories can be frontally accessed without completely removing it. The withdrawable circuit-breaker is inserted and removed via dedicated guide rails that simplify movement. The correct movement from racked-in, test isolated, to racked-out position is guaranteed by a lock in each position. As a further guarantee of safety, the shutters of the fixed part can be locked from the front when the circuit-breaker is removed; the shutters of the upper terminals are independent of those of the lower terminals to facilitate checking and maintenance operations. The Ekip Touch protection trip units are equipped with a large colour touch-screen display which enables safe and intuitive operation.

Breakers, Switches & Fusegear for Utility

ABB Product Portfolio

Tmax - Molded Case Circuit Breakers



General

Tmax family is available as a complete range molded case circuit breakers up to 1600A. All the circuit-breakers, both three-pole and four-pole, are available in the fixed version, XT1, XT2, XT3, XT4 and T5 in the plug-in version and XT2, XT4, T5, T6 and T7 in the withdrawable one as well. Within the same frame size, the circuit-breakers in the Tmax family, are available with different breaking capacities and different rated uninterrupted currents.

Outstanding performance

The electric arc interruption system used on the Tmax circuit-breakers allows the short-circuit currents of very high value to be interrupted extremely rapidly. The considerable opening speed of the contacts notably limits the value of the specific let through energy I^2t and the current peak.

Remote Control and Supervision

Circuit breakers of the Tmax family can be remotely commanded in opening and closing, even by means of bus communication. All status, alarms and measurements performed by the breakers can be sent through local or system buses to supervising systems.

Installation

Tmax circuit-breakers are very flexible: they can be installed in the switchboards, mounted in any horizontal, vertical or lying down position, without undergoing any derating of their rated characteristics. Tmax circuit-breakers can be installed easily in all types of switchboards, above all thanks to the wide possibility of being supplied either by top or bottom terminals, without jeopardizing the apparatus functionality.

OT - Switch Disconnecter



Optimal size, easy to install

OT's provide the most compact switch-disconnecting solution. This is possible thanks to a uniquely short current path that runs straight through the switch when in closed position. Also, the double-spring construction in the mechanism and double-openings in the power-poles contribute to a uniquely simple, compact design. ABB's switches therefore have a small footprint area, taking less valuable space, and allow installation in confined spaces. Simple and compact, the OT's are straight forward and easy to install. Space savings mean savings in total cost, and easy installation saves valuable time.

Outstanding performance

Despite their compact size, the OT switch-disconnectors are designed for high performance. Most of the OT AC switch-disconnectors have full AC-23A current ratings for voltage levels up to 690 V, and even 1000 V ratings are provided. ABB switch-disconnectors' powerful mechanism provide "quick-make, quick-break" operation that is independent from users operating speed. The full thermal-current ratings are sized for both open-air and use in enclosures, so there is no need for derating the switch or increasing the size of the enclosure or cabinet. The strong performance makes OT switches suitable for a diverse range of applications.

Enhanced safety

Safety is often the fundamental motive for switch-disconnector application. Therefore the safety features and properties of OT's are numerous and in an essential role in the overall design. Safety related normative requirements are strictly applied. General reliability in operation, reliable insulation and isolation features, as well as reliable position-indication features are standard for all OT switches. Uniquely, the OT design includes special windows to keep the actual contacts visible for inspection, providing see-it-for-yourself proof about the position of the switch. Safety is paramount.

Breakers, Switches & Fusegear for Utility

ABB Product Portfolio

In Line - Vertical Fusegear



General

The InLine family consist of Fuse rails, Single- and triple pole manually operated Fuse switch disconnectors from 160A up to 1250A. In addition the family consist of several types of Incoming units to complete the product family for Utility applications.

Outstanding performance

The InLine family of Fuse Switch Disconnectors are made for DIN NH size fuses according to IEC 60269-1-2. Because the fuse elements operate inside a ceramic housing, and do not have any mechanism inside to be maintained, they are less affected by the surroundings. Consequently InLine Fuse Switch Disconnectors remain stable as short circuit and overload protection year after year. Another huge argument for InLine Fuse Switch Disconnectors in Utility network is the easy and reliable selectivity calculation. Fuse links will assure selectivity in the installation if it is 1,6:1 difference in between the upstream/downstream currents. With this consideration, only the fuse nearby the fault will trip and the upstream fuses will still be live. If a fuse is blown inside an InLine product, only the fuse link has to be changed to restore the system. InLine and its material and functional constructions are made with the highest consideration regarding safe operation and easy for the operator to change a fuse that has blown without touching any live parts. The InLine product family is maintenance free.

Remote control and Supervision

The InLine range is manually operated, however with many options for supervision. Electronic Fuse Monitoring (EFM) with local indication via LED's and option for remote supervision. The EFM is self-supplied i.e no need for Aux. power. Position indicators are available as accessories both Aux. switch and Micro switches for the complete range. Current transformers can be mounted on either the rear side of the fuse base, or at cable connection area. Amp. Meter housing can be fitted easily on top of each unit.

Installation

Fusegear apparatus like InLine are in general made according to IEC 60947-3 and are mounted on flat busbar with 185mm phase distance. All InLine Fuse Switch Disconnectors can easily be mounted for cable entrance below or above without any extra components needed. This can be done by rotating the base 180 degrees, without influence on the operating handles position. The outgoing cables can be connected by universal bolts at cable lugs, or cable clamps for different sizes. The InLine family is prepared for both Cu and Al cables. Most important requirements and specifications are implemented to make sure InLine is applicable for world-wide customer solutions.

Kabeldon IP-system - IP2X



Another fusegear system offered by ABB is the Kabeldon IP-system which consists of a unique, screen protected (IP2X) busbar system with 85 mm phase distance, 400A - 2500A, and a wide range of switching devices such as fuse switch disconnectors with dependent manual operation, switching devices with independent handmanover, connectors, disconnectors and accessories.

Cable Distribution Cabinets



Cable distribution cabinets/pillars are stationary assemblies for outdoor installation. They are for use in public three-phase systems (IEC 61439-5, PENDA-O) and ABB offers a wide range of efficient, flexible and reliable components for different applications.

Our cable distribution cabinets and distribution boards for outdoor use fits in well in most environments. They come in various design and sizes with different features. Type of enclosure is chosen based on type of busbar-/fusegear system and type of application.

Contact us

ABB SACE

Una divisione di ABB S.p.A.

Interruttori B.T.

Via Baioni, 35

24123 Bergamo

Tel: 035 395.111

Fax: 035 395.306-433

www.abb.it/lowvoltage

Dati e immagini non sono impegnativi. In funzione dello sviluppo tecnico e dei prodotti, ci riserviamo il diritto di modificare il contenuto di questo documento senza alcuna notifica.

Copyright 2014 ABB. All rights reserved.

1SDCxxxxxB0901 - 03.2014

Power and productivity
for a better world™

