

Application

The 88 QT02-E/R1013 bus coupling module serves to interconnect the station-bus and the IO-bus.

It provides data communication between these two bus systems and also permits data processing in addition to pure data transfer.

At the station-bus, the module acts like a combined input and output module which can receive up to 192 telegrams from and transfer up to 192 telegrams to the station-bus.

In relation to the IO-bus, the module has the function of a bus control module in that it controls data communication.

DIFFERENCES BETWEEN MODULE VERSION R1011 AND MODULE VERSION R1013

Compared with module version R1011, version R1013 offers the following additional capabilities:

- Provision for direct input and output of telegrams on the same IO-bus
- Extension of updating to control modules connected to the IO-bus
- Deactivation of plausibility check if desired
- Modification of data type for binary input modules 81 EB10
- Extension of diagnostic telegram under register address 211 to include error code 5: process disturbance in the input module.

Features

The module can be plugged into every multi-purpose processing station of the PROCONTROL bus system; it has a slot requirement of 2 divisions.

It incorporates:

- A standard interface SS to the station-bus.
- A standard interface SEA to the IO-bus.

In contrast to the IO-bus input or output modules, it actively controls the lines for clock and for the addresses.

- A standard interface SRP to the RAM Pack 83 RP01.

At the station-bus, the module behaves like a combined input and output module; its module address, like that of all station-bus modules, relates to the place of installation.

In its function as a bus control module, it actively controls data transfer on the IO-bus.

It continuously checks the allocation of the IO-bus to IO-bus input modules and transfers their data to the station-bus.

It cyclically supplies the projected IO-bus output modules with the data received from the station-bus.

Proper functioning of the IO-bus and of the connected IO-bus modules is monitored.

Disturbances are signalled to the higher-order system by means of two diagnostic telegrams, and additionally signalled on the module via two light-emitting diodes.

The module includes provision for updating the IO-bus allocation to input or output modules and for simulating output data.

Description

Basically, the module consists of two functional blocks, a IO-bus-specific one and a station-bus-specific one, which are interfaced by two shared memories.

The performed functions include the following:

- Sequential control on the IO-bus by active operation of IO-bus lines CLK and ADR.
- Conditioning of the data in input direction by input signal monitoring, limit value formation, linearization and event detection.
- Conditioning of the data in output direction by marshalling and measuring range extension.
- Controlled data communication with the station-bus.
- Monitoring of the functions of the IO-bus modules and diagnosis message to the station-bus.
- Monitoring of its own functions and diagnosis message to the station-bus.
- Documentation update of IO-bus allocation to IO-bus modules for the station-bus.
- Simulation of output data.

The module consists of two printed circuit boards.

The upper printed circuit board, the station-bus-specific section, contains processors and various memory modules. It is accommodated on the standard printed circuit board "Station bus adaption version R1400" and is provided for communication between the module and the station-bus.

The IO-bus-specific section is located on the lower printed circuit board of the module. It is responsible for the smooth running of operations on the IO-bus.

The interface with the IO-bus is potential-isolated by optocouplers.

The individual module functions are described in more detail below.

INITIALIZATION

Initialization is the process of setting the bus coupling module to a defined initial state and establishing the allocation of the IO-bus (creating the bus allocation list).

Initialization is carried out:

- by application of the voltage (plugging-in of the module).
- after reception of the instruction telegram "reset processing".

During the initialization phase, the light-emitting diode for disturbance annunciation, STEA, emits a flashing light for approx. 4 seconds in order to allow the IO-bus modules to reach the ready status.

The status message in status register 248 indicates that normal processing has been started.

PLUGGING-IN OF MODULES AT THE IO-BUS

The bus coupling module 88 QT02 and the IO-bus modules can be plugged in during operation. More detailed information is given in the section "Features" in the module descriptions of the individual IO-bus modules.

When the bus coupling module is plugged in, its initialization is performed automatically and the IO-bus is connected to the station-bus after the initialization phase.

Only one bus coupling module can be used per IO-bus.

IO-bus modules are unable to function without bus coupling modules since they need the bus control functions of the bus coupling modules for proper operation.

By pressing the reset pushbutton RST on the front of the bus coupling module, the IO-bus allocation list with input modules is completely updated; this is necessary whenever a new IO-bus module has been plugged in.

Processing

Both functional blocks, i.e. the IO-bus-specific section and the station-bus-specific section of the module, cooperate via the shared memories.

While the IO-bus-specific section cyclically updates the data in the send shared memory and cyclically reads out the data in the receive shared memory, the station-bus-specific section ensures evaluation and conditioning of the shared memory data.

The IO-bus-specific section scans the input modules connected to the IO-bus, on the basis of the IO-bus allocation list, checks the incoming data for plausibility and passes them on to the send shared memory.

The processing frequency is adapted to suit the rate of change of the individual data types, e.g. binary values are scanned much more frequently than analog values.

Furthermore, the data for IO-bus output modules, which were conditioned on the basis of the marshalling information and the range code, if available, are output to the IO-bus.

Data exchange between the IO-bus-specific section and the IO-bus modules takes place by means of IO-bus telegrams.

The formats of the address, data and specification telegrams for the individual IO-bus modules are specified in the sections "Formation of telegrams" of the respective module description.

The general telegram structure on the IO-bus is dealt with in the operating principles description "IO-bus, characteristics and system data, GKWE 705 333".

In the case of input modules, the module type is recognized with the aid of the specification telegram, and the signals are conditioned accordingly.

Output modules are projected, the processing function to be performed by the coupling module being defined by plant-specific planning.

The following processing functions are performed.

In input direction:

- Binary values: Event acquisition
- Analog values: Input signal-limit value and threshold value monitoring, event acquisition (linearization with analog temperature values)
- Counter values: Operating mode 2 x 16 bit counter,
Operating mode 1 x 32 bit counter
(no event acquisition)

In output direction:

- Binary values: Marshalling to optional IO-bus output address 0 ... 255
Single bit marshalling
- Analog values: Marshalling to optional IO-bus output address 0 ... 255
Expansion of the respective output value

It is possible to output a station-bus telegram or a telegram received from the IO-bus to various IO-bus addresses and, for instance, to provide for different measuring range expansions with the same analog value.

Data communication with the station-bus is handled by the station-bus-specific section using station-bus telegrams.

The bus coupling module participates in the station bus communication in the same way as every station-bus input or output module; its module address is related to the place of installation (source location address).

INPUT SIGNAL MONITORING

The analog values of the analog input modules connected to the IO-bus are monitored for plausibility within permanently set limits.

The monitoring feature responds when the input signal exceeds 118 % or falls below -6 % of the set measuring range.

If the monitoring feature responds, bit 14 is set in diagnosis register 246 (process disturbance).

However, the disturbed measured value is transferred together with the set disturbance bit. In addition, light-emitting diode ST is set.

LIMIT SIGNAL FORMATION

During processing of an analog value read in from the IO-bus, a comparison with up to four relevant limit values is carried out.

The position of the analog value relative to these four limit values is recorded in a special limit value telegram which is entered in the send shared memory register that follows the analog value. (Even register address for analog value, the following odd register address for limit value information. Under the subsequent odd IO-bus address, the associated IO-bus input module transfers the specification telegram.)

The limit value register following the respective analog value register is designed according to data type 3.

In addition, the difference is formed between the current analog value and the last-transferred analog value of the function unit.

If this difference is larger than the specified threshold value, event annunciation for this value is initiated.

In addition, the following details must be filed for each limit value:

- One of the four hysteresis values stated in the following can be assigned to every individual limit value.
HY1 = 0.39 %; HY2 = 1.56 %*; HY3 = 3.12 %;
HY4 = 6.25 %
* Standard setting
- The hysteresis can be above or below the limit value, depending on whether violation of the minimum or maximum limit value is to be indicated.

Alteration of a limit signal is signalled as event to the station-bus.

If the input signal monitoring responds, all projected limit signals (GOXX, GUXX) assigned to the measured value are set to "0", and the disturbance bit (MXX, SMX) is set to "1" (see telegram allocation).

The range for limit values is 0 % - 110 % of the set measuring range.

LINEARIZATION

Analog values from temperature input modules are linearized by the processing section.

Linearization is achieved by comparing lists.

EVENT GENERATION

Since IO-bus modules have no event capability, this function is taken care of by the bus coupling module.

Normally, the bus coupling module is requested cyclically by the PROCONTROL bus system to transfer its data. If values change within this cycle time, this is treated as an "event".

The bus coupling module recognizes as event:

In the case of analog input modules:

- Response of a limit signal.
- Response of the input signal monitoring.
- Alteration of a measured value by more than the permissible set value (threshold value), related to the last value transferred to the station-bus.

In the case of binary input modules:

- Alteration in any bit in the data telegram.

When an event occurs, the new values are transferred with priority to the PROCONTROL bus system according to the modalities of event-oriented transfer.

MARSHALLING OF OUTPUT VALUES

Using the marshalling list, the values received from the station-bus on the basis of the bus address list and stored in the receive shared memory can be assigned to any of the IO-bus output addresses 0...255.

For analog values, this is done in connection with the range code list, which can be used to expand the analog values.

For binary values, every individual bit can be marshalled with the aid of the marshalling list in connection with the bit multiplex table.

Addressing and data communication with the station-bus

Data exchange between the module and the station-bus is effected via the two shared memories of the bus coupling module, where the incoming station-bus telegrams as well as the station-bus telegrams to be transferred are buffered.

For this purpose, the send shared memory incorporates source registers for station-bus telegrams to be transferred, while the receive shared memory contains sink registers for station-bus telegrams to be received.

INPUT MODULES

The IO-bus input function units are allocated to the source registers of the send shared memory using address switches on the IO-bus modules (1 to 1 allocation).

The even-numbered source register contains the data telegram.

The subsequent odd-numbered source register contains:

- The relevant limit value telegram for analog inputs.
- A blank telegram for all other input modules (exceptions 81 EB10 and 81 EZ10 in 32-bit mode).

If an IO-bus telegram from source modules of the IO-bus fails to arrive, the associated regular data telegram to the station-bus (which can be evaluated by the sink registers) is also missing, so that sink monitoring can become effective.

The telegram allocation is shown in detail in the following telegram table.

OUTPUT MODULES

The bus address list contains the source location addresses of all telegrams which are to be received by the module, and their allocation to the sink registers of the receive shared memory.

The allocation of the sink registers of the receive shared memory or, in the case of direct transfer (IO-bus - 88 QT02 - IO-bus), the allocation of the registers in the send shared memory to the IO-bus output function units does not take place in 1 to 1 allocation, but is rather determined by specifications of the user (marshalling list).

Bus address list and marshalling list are filed on PROMs in the user memory.

Received telegrams whose addresses are not included in the bus address list are ignored by the module.

Received telegrams whose addresses are included in the bus address list are written into the sink registers of the receive shared memory.

The bus address list and the marshalling list are generated automatically by the transfer program when the address is entered.

CONTROL MODULES

The control modules, as combined input/output modules, are of a special nature.

The bus coupling module sends a telegram to the SR module of the IO-bus under an even-numbered IO-bus address. It receives a telegram from the SR module of the IO-bus under the next odd-numbered IO-bus address.

The SR modules of the IO-bus have the address extension 0. The starting address range valid for these modules is the same as for the binary input modules 81 EB10 0...190 (191 is automatically reserved for the sequence address).

The telegram transferred by SR modules is treated by the bus coupling module like the telegram of a binary input module 81 EB10 (event location, 1 to 1 allocation).

The telegram transferred by the bus coupling module is treated like the telegram to a binary output module 81 AB10 (bus address list, marshalling list).

TELEGRAM ALLOCATION OF THE SEND SHARED MEMORY BY INPUT MODULES.

IO BUS Addr.	Reg. no	Information	Telegram																DA
			← Bit position →																
			15	14	13	12	11	10	9	8	7	6	5	4	3	2	1	0	
n+256	n+256	Analog value 81 EA10 FEX (1 ...32)	VZ	100%	50%	25%	12,5%	6,25%	3,125%	1,56%	0,78%	0,39%	0,195%	0,097%	0,048%	0	0	SB	5
n+1+256	n+1+256	Limit value FEX (1 ...32)	0	0	0	GOX4	GUX4	MX4	GOX3	GUX3	MX3	GOX2	GUX2	MX2	GOX1	GUX1	MX1	SMX	3
n+256	n+256	Analog value 81 EA11 FEX (1 ...16)	VZ	100%	50%	25%	12,5%	6,25%	3,125%	1,56%	0,78%	0,39%	0,195%	0,097%	0,048%	0	0	SB	5
n+1+256	n+1+256	Limit value FEX (1 ...16)	0	0	0	GOX4	GUX4	MX4	GOX3	GUX3	MX3	GOX2	GUX2	MX2	GOX1	GUX1	MX1	SMX	3
n+256	n+256	Binary value 81 EB10 FE1 ...16	EB16	EB15	EB14	EB13	EB12	EB11	EB10	EB09	EB08	EB07	EB06	EB05	EB04	EB03	EB02	EB01	1
n+1+256	n+1+256	Binary value 81 EB10 FE17 ...32	EB32	EB31	EB30	EB29	EB28	EB27	EB26	EB25	EB24	EB23	EB22	EB21	EB20	EB19	EB18	EB17	1
n+256	n+256	Binary value 81 EB11 FE1 ...4	0	0	0	R4	NR4	0	R3	NR3	0	R2	NR2	0	R1	NR1	0	SM1	1
n+1+256	n+1+256		Blank telegram																11
n+2+256	n+2+256	Binary value 81 EB11 FE5 ...8	0	0	0	R8	NR8	0	R7	NR7	0	R6	NR6	0	R5	NR5	0	SM2	1
n+3+256	n+3+256		Blank telegram																11
n+4+256	n+4+256	Binary value 81 EB11 FE9 ...12	0	0	0	R12	NR12	0	R11	NR11	0	R10	NR10	0	R9	NR9	0	SM3	1
n+5+256	n+5+256		Blank telegram																11
n+6+256	n+6+256	Binary value 81 EB11 FE13 ...16	0	0	0	R16	NR16	0	R15	NR15	0	R14	NR14	0	R13	NR13	0	SM4	1
n+7+256	n+7+256		Blank telegram																11
n+256	n+256	Temp. value 81 ET10 FEX (1 ... 16 or 1 ... 32)	VZ	100%	50%	25%	12,5%	6,25%	3,125%	1,56%	0,78%	0,39%	0,195%	0,097%	0,048%	MB	MB	SB	6
n+1+256	n+1+256	Limit value FEX (1 ... 16 or 1 ... 32)	0	0	0	GOX4	GUX4	MX4	GOX3	GUX3	MX3	GOX2	GUX2	MX2	GOX1	GUX1	MX1	SMX	3
n+256	n+256	Resistance value 81 EW10 FEX (1 ...16)	VZ	100%	50%	25%	12,5%	6,25%	3,125%	1,56%	0,78%	0,39%	0,195%	0,097%	0,048%	MB	MB	SB	6
n+1+256	n+1+256	Limit value FEX (1 ...16)	0	0	0	GOX4	GUX4	MX4	GOX3	GUX3	MX3	GOX2	GUX2	MX2	GOX1	GUX1	MX1	SMX	3

* see page /9

TELEGRAM ALLOCATION OF THE SEND SHARED MEMORY BY INPUT MODULES (continued).

IO BUS Addr.	Reg. no	Information	Telegram														DA		
			← Bit position →																
			15	14	13	12	11	10	9	8	7	6	5	4	3	2	1	0	
n+256	n+256	Counter value 81 EZ10 FE1	0	2 ¹³	2 ¹²	2 ¹¹	2 ¹⁰	2 ⁹	2 ⁸	2 ⁷	2 ⁶	2 ⁵	2 ⁴	2 ³	2 ²	2 ¹	2 ⁰	SB	4
n+1+256	n+1+256	16 bit word length Op. mode: binary	Blank telegram														11		
n+2+256	n+2+256	Counter value 81 EZ10 FE2	0	2 ¹³	2 ¹²	2 ¹¹	2 ¹⁰	2 ⁹	2 ⁸	2 ⁷	2 ⁶	2 ⁵	2 ⁴	2 ³	2 ²	2 ¹	2 ⁰	SB	4
n+3+256	n+3+256	16 bit word length Op. mode: binary	Blank telegram														11		
n+256	n+256	Counter value 81 EZ10 FE1	VZ	2 ¹³	2 ¹²	2 ¹¹	2 ¹⁰	2 ⁹	2 ⁸	2 ⁷	2 ⁶	2 ⁵	2 ⁴	2 ³	2 ²	2 ¹	2 ⁰	SB	4
n+1+256	n+1+256	16 bit word length Op. mode: code conversion	Blank telegram.														11		
n+2+256	n+2+256	Counter value 81 EZ10 FE2	VZ	2 ¹³	2 ¹²	2 ¹¹	2 ¹⁰	2 ⁹	2 ⁸	2 ⁷	2 ⁶	2 ⁵	2 ⁴	2 ³	2 ²	2 ¹	2 ⁰	SB	4
n+3+256	n+3+256	16 bit word length Op. mode: code conversion	Blank telegram														11		
			Data byte				Consecutive ★★ byte no.				Consistency ★★★ identification								
n+256	n+256	Counter value 81 EZ10 32 bit word length Op. mode: binary	0	2 ²⁹	2 ²⁸	2 ²⁷	2 ²⁶	2 ²⁵	2 ²⁴	2 ²³	0	0	0	0				SB	29
n+1+256	n+1+256		2 ²²	2 ²¹	2 ²⁰	2 ¹⁹	2 ¹⁸	2 ¹⁷	2 ¹⁶	2 ¹⁵	0	0	0	1				SB	29
n+2+256	n+2+256		2 ¹⁴	2 ¹³	2 ¹²	2 ¹¹	2 ¹⁰	2 ⁹	2 ⁸	2 ⁷	0	0	1	0				SB	29
n+3+256	n+3+256		2 ⁶	2 ⁵	2 ⁴	2 ³	2 ²	2 ¹	2 ⁰	SB	0	0	1	1				SB	29
n+256	n+256	Counter value 81 EZ10 32 bit word length Op. mode: code conversion	VZ	VZ	VZ	2 ²⁷	2 ²⁶	2 ²⁵	2 ²⁴	2 ²³	0	0	0	0				SB	29
n+1+256	n+1+256		2 ²²	2 ²¹	2 ²⁰	2 ¹⁹	2 ¹⁸	2 ¹⁷	2 ¹⁶	2 ¹⁵	0	0	0	1				SB	29
n+2+256	n+2+256		2 ¹⁴	2 ¹³	2 ¹²	2 ¹¹	2 ¹⁰	2 ⁹	2 ⁸	2 ⁷	0	0	1	0				SB	29
n+3+256	n+3+256		2 ⁶	2 ⁵	2 ⁴	2 ³	2 ²	2 ¹	2 ⁰	SB	0	0	1	1				SB	29
210	Updating Bus coupling module	Type of coupling module (Bus coupling module 88 QT02 = 6)				0	0	0	0	0	0	0	0	0	0	0	0	0	
211	Diagnosis signals IO BUS	Processing IO BUS disturbed		Address extension IO BUS modules		IO BUS module address or additional information						0							
246	Standard diagnosis telegram	Processing and process disturbed		Bus adaption disturbed		Reception disturbed			Transmitter disturbed			0							
248	Standard status telegram	Standard status annunciations GA = 0 - 58														0			

★, ★★, ★★★ see page /9

TELEGRAM ALLOCATION OF THE SEND SHARED MEMORY BY INPUT MODULES (continued).

IO BUS Addr.	Reg. no. *	Information	Telegram																DA
			← Bit position →																
			15	14	13	12	11	10	9	8	7	6	5	4	3	2	1	0	
		83 SR10	IO BUS receive telegram at 83 SR10 from 1 ... 16 station BUS telegrams (bit-by-bit marshalling)																
n		Receive telegram FE1 + FE2	E16	E15	E14	E13	E12	E11	E10	E09	E08	E07	E06	E05	E04	E03	E02	E01	
n+1	n+1+256	Send telegram FE1 + FE2	A16	A15	A14	A13	A12	A11	A10	A09	A08	A07	A06	A05	A04	A03	A02	A01	0
		83 SR11	IO BUS receive telegrams at 83 SR11 are standard telegrams (marshalling of complete telegrams)																
n		Receive telegram FE1								B20 (B12)	B10 (B11)								
n+1	n+1+256	Send telegram FE1										MFO/UE (UE1)	MFZ/UA (UA1)	E20 (E12)	E10 (E11)	STA (STA1)	VO (VO1)	STE (STE1)	0
n+2		Receive telegram FE2								B20 (B22)	B10 (B21)								
n+3	n+3+256	Send telegram FE2	ASS									MFO/UE (MFO1/UE1)	MFZ/UA (MFZ1/UA1)	E20 (E22)	E10 (E21)	STA (STA2)	VO (VO2)	STE (STE2)	0
n+4		Receive telegram FE3								B20 (B32)	B10 (B31)								
n+5	n+5+256	Send telegram FE3										MFO/UE (UE1)	MFZ/UA (UA1)	E20 (E32)	E10 (E31)	STA (STA3)	VO (VO3)	STE (STE3)	0
n+6		Receive telegram FE4								B20 (B42)	B10 (B41)								
n+7	n+7+256	Send telegram FE4	ASS									MFO/UE (MFO2/UE1)	MFZ/UA (MFZ2/UA1)	E20 (E42)	E10 (E41)	STA (STA4)	VO (VO4)	STE (STE4)	0
		87 WF10	IO BUS receive telegrams at 87 WF10 are standard telegrams (marshalling of complete telegrams)																
n		Receive telegram FE1					BLS (L14)	DL (L14)		BLS (L13)	DL (L13)	BLL (L12)	BLS (L12)	DL (L12)	BLL (L11)	BLS (L11)	DL (L11)		
n+1	n+1+256	Send telegram FE1				TF (TF1)		TH (T13)	T20 (T12)	T10 (T11)		TF (TF1)	T4 (T23)	T3 (T13)	T2 (T12)	T1 (T11)			0
n+2		Receive telegram FE2				BLS (L24)	DL (L24)		BLS (L23)	DL (L23)	BLL (L22)	BLS (L22)	DL (L22)	BLL (L21)	BLS (L21)	DL (L21)			
n+3	n+3+256	Send telegram FE2				TF (TF2)		TH (T23)	T20 (T22)	T10 (T21)		TF (TF2)		T3 (T23)	T2 (T22)	T1 (T21)			0
n+4		Receive telegram FE3				BLS (L34)	DL (L34)		BLS (L33)	DL (L33)	BLL (L32)	BLS (L32)	DL (L32)	BLL (L31)	BLS (L31)	DL (L31)			
n+5	n+5+256	Send telegram FE3				TF (TF3)		TH (T33)	T20 (T32)	T10 (T31)		TF (TF3)		T3 (T33)	T2 (T32)	T1 (T31)			0
n+6		Receive telegram FE4				BLS (L44)	DL (L44)		BLS (L43)	DL (L43)	BLL (L42)	BLS (L42)	DL (L42)	BLL (L41)	BLS (L41)	DL (L41)			
n+7	n+7+256	Send telegram FE4				TF (TF4)		TH (T43)	T20 (T42)	T10 (T41)		TF (TF4)		T3 (T43)	T2 (T42)	T1 (T41)			0

* see page /9

Explanation of abbreviations used:

SMX	=	General disturbance bit telegram
SB	=	Disturbance bit telegram
MXX	=	Indiv. disturb. announc. limit value X
VZ	=	Sign
MB	=	Measuring range (temperature) ****
GOXX	=	Maximum limit value X violated
GUXX	=	Minimum limit value X violated
FEX	=	Function unit
EBXX	=	Binary input signal XX
RX	=	Binary input signal X
NRX	=	Binary input signal X inverted
2 ^X	=	Signific bit position counter signal X
XX	=	Function unit number
DA	=	Data type in the station-bus telegram
GA	=	Module address

The meaning of the abbreviations used in connection with modules 83 SR10, 83 SR11 and 83 WF10 is explained in the module description of the module concerned.

* Register number:

$N + x + 256$ applies for the shared memory allocation at 88 QT02.

In order to read out the shared memory register via PDAG or 89 PT01, $n + x$ applies (256 is automatically suppressed in 88 QT02).

** Byte number:

In order to ensure the correct sequence of related useful data from several individual telegrams, the consecutive byte number is entered in every telegram (Consecutive numbering with 4 bit binary number).

*** Consistency code:

In order to mark related individual telegrams as contiguous, they are given the same consistency code (3 bit binary number).

**** Measuring range (temperature)

Permissible measuring ranges on the 81 ET10 and 81 EW10 modules:

00	=	0 °C ... 150 °C
01	=	0 °C ... 300 °C
10	=	0 °C ... 600 °C
11	=	0 °C ... 1000 °C

CAPACITY OF AVAILABLE SHARED MEMORIES AND IO-BUS ALLOCATION

The module has a send shared memory for telegrams from the IO-bus to the station-bus and a receive shared memory for telegrams from the station-bus to the IO-bus.

If telegrams are directly transferred between IO-bus - 88 QT02 - IO-bus, recourse is had to the send shared memory when serving output modules.

Both shared memories provide the connection between the IO-bus-specific section and the station-bus-specific section of the module. The receive shared memory can take up 192 telegrams from the station-bus.

The send shared memory contains up to 192 telegrams for the station-bus.

The module starting address of the IO-bus input or output modules is determined by the address switches S1, S2 and S3.

The address switch S1 includes the address extension for the bus coupling module, by which it recognizes whether input modules transfer specification telegrams or not.

In this way, a distinction is made between ranges 0 - 255 and 256 - 511 with respect to the address.

- Address extension 0: Input module transfers no specification telegrams or output module (then projected)

- Address extension 1: Input module transfers specification telegrams

INPUT MODULES

The telegrams of the IO-bus input modules are filed in the send shared memory (maximum 192) which takes account of the following conditions:

- A 1 to 1 allocation is provided in the input direction, which means that the IO-bus address S2 and S3 is identical with the register address in the respective station-bus telegram.

- For IO-bus input modules with address extension 0 (81 EB10), IO-bus addresses 0-191 can be allocated.

- For IO-bus input modules with address extension 1, IO-bus addresses 256-447 can be allocated.

- Only one input module is possible for an IO-bus address (S2 and S3). Double allocation of addresses with different address extensions by IO-bus input modules is signalled as a disturbance.

Input modules with address extension 0 and 1 occupy the same memory areas in the send shared memory since the address extension is not evaluated for allocation of the send shared memory.

- Only those input modules are called in the processing cycle, the presence of which is recognized in the background program and which are recorded in the bus allocation list.
- The following input modules are ignored and indicated with a disturbance annunciation:

Input modules with address extension 0 (81 EB10) and an address larger than 191.

Input modules with address extension of 1 and an address larger than 447.

OUTPUT MODULES

The telegrams of the IO-bus output modules are taken care of by the receive shared memory (maximum 192 telegrams) which takes account of the following conditions:

- There is no 1 to 1 allocation in the output direction. Instead, the information regarding the shared memory registers from which an output value is to be fetched, and the IO-bus output function unit to which this value is to be output, is given explicitly in special transfer parameters (marshalling information).
- Only such output modules are served in the processing cycle which are projected. Proper data reception is monitored by the acknowledgement signal.
- In IO-bus output modules, address extension 0 must always be set. IO-bus addresses 0-255 can here be used, with the number of the function units of the output modules that can be served depending on the number of the station-bus telegrams needed and on the memory capacity (see right-hand side).

- The following maximum number of output modules can be connected per bus coupling module:

32 81 AA10 $\hat{=}$ 32 x 8 = 256,
however, from max. 192
station-bus telegrams

37 81 AB10/R0100 $\hat{=}$ 37 x 32 = 1184 binary
values, however, from 192
station-bus telegrams

60 81 AB10/R0200 $\hat{=}$ 60 x 16 = 960 binary
values, however, from 192
station-bus telegrams

60 83 SR10 $\hat{=}$ 60 x 16 = 960 binary
values, however, from 192
station-bus telegrams

Care must be taken to ensure that every IO-bus module is assigned the address range on the IO-bus it actually requires, in order to avoid overlapping of addresses. The required address range depends on the number of function units located on the module.

For reasons of data transfer, the number of IO-bus modules that can be connected to each IO-bus is limited to a maximum of 60.

The complete address range of this type of module is always allocated, irrespective of the number of function units used on an input or output module.

EXAMPLES FOR IO-BUS ALLOCATION

The addresses enable the station-bus to gain selective access to the shared memory registers, and hence to the individual function units of the IO-bus modules.

Because of the address extension 0, a maximum of 256 addresses is available for output modules on the IO-bus.

Allocation of the IO-bus to input modules only:

- The capacity of the available send shared memory permits the use of input modules with a common maximum of 192 IO-bus addresses which correspond to the register address in the station-bus telegram as a result of the 1 to 1 allocation.
- Input modules are classified into modules with address extension 0 and modules with address extension 1.

- When allocating input modules to address extension 0, the address range available for output modules is limited. However, the allocation of input modules with address extension 1 does not affect the address range for output modules (address extension 0).

E.g.: It is possible to allocate three modules 81 ET10/R0100 (address extension 1), each with 32 addresses for data telegrams and 32 addresses for specification telegrams, giving a total of 192 input addresses.

E.g.: It is possible to allocate two modules 81 ET10/R0100 (address extension 1) and additionally 32 modules 81 EB10 (address extension 0). This gives a total of 192 input addresses, and the address range for output modules is not fully utilized.

Allocation of the IO-bus to output modules only:

- Output modules have the address extension 0.
- There is a maximum of 192 different sink registers available, from which all output modules must be served.
- As there is no 1 to 1 allocation of the IO-bus telegrams to the station-bus telegrams, it is not possible to specify the maximum number of output modules.

E.g.: Between 1 and 16 station-bus telegrams are required for the binary signal output module 81 AB10/R0200. The number of the telegrams and hence the number of the binary output modules depends on whether all binary output signals originate from one station-bus telegram, or whether every binary output signal comes from a different station-bus telegram. For analog output modules, one station-bus telegram is necessary for each of the analog values to be output (precondition: no multiple output of a telegram to several addresses).

Allocation of the IO-bus to input and output modules:

- If input modules with address extension 0 and output modules are connected to the IO-bus, it is possible to allocate input modules to the addresses 0...191 or to allocate output modules to the addresses 0...255.
- Addresses 256-447 are available for input modules with address extension 1.
- The allocation limits are determined by the memory capacity of the two shared memories each of which can store 192 telegrams.

E.g.: Allocation of IO-bus addresses 0-63 to 32 modules 81 EB10/R0100 with address extension 0, and of addresses 320-447 to 2 modules 81 ET10/R0100 with address extension 1.

Furthermore, allocation of IO-bus addresses 64-255 to 12 modules 81 AB10/R0200, assuming that every binary output signal of the binary output modules is taken from another station-bus telegram and not output more often.

In this allocation example, the shared memory registers of both shared memories are fully utilized.

USER MEMORY

The user memory provides the module with the information needed for marshalling and processing data telegrams.

The user memory consists of two PROMs which are installed on the mounting places A401 and A407 of the station-bus adaption (upper printed circuit board). They contain the following lists:

- Bus address list
- Marshalling list
- Range code list
- Bit multiplex list
- Limit value list
- Threshold value list

The user memory is defined in the planning phase in accordance with the customer specific requirements and cannot be changed on-line.

For IO-bus input modules, the following information can be filed in the user memory.

Analog input modules:

- Up to four process-specific limit values with the relevant hysteresis information per function unit.
- One threshold value per function unit.

For IO-bus output modules, the following information is filed in the user memory.

Analog output modules:

- Allocation of the receive register addresses or, in the case of direct output, of the register addresses in the send shared memory to the IO-bus addresses and, therefore, to the respective function units of an analog output module (marshalling information).
- Specifications for the measuring range expansion per analog output function unit (range code).

Binary output modules:

- Allocation of the receive register addresses or, in the case of direct output, of the register addresses in the send shared memory to the IO-bus addresses (marshalling information).
- Compilation of the IO-bus telegrams of the binary output modules from the receive registers or, in the case of direct output, from the send shared memory registers. It is possible to marshall every individual bit (bit multiplex table).

The limit values and threshold values stored in the user memory can only be changed, for commissioning and similar purposes, in connection with the RAM-Pack 83 RP01.

SIMULATION MEMORY

To simulate analog and binary output values, special memory areas are available on the bus coupling module.

Instead of the value received via the station-bus in the receive shared memory, a temporary substitute value is output from the simulation memory via the function unit to be simulated of the output module concerned.

Before fetching an output value from the receive shared memory, the bus coupling module checks whether a simulation value is entered for this value in the simulation memory.

For binary output modules it is possible to determine for every bit whether it is to be simulated or not.

Simulation of output data is indicated locally on the module by light-emitting diode SIM as well as in the status register.

Operation with RAM-Pack 83 RP01

On the front of the module, connector X1 is arranged. It incorporates a standard interface SRP to the RAM-Pack 83 RP01.

The RAM-Pack is a non-volatile read-write memory in which parts of the user memory of the bus coupling module can be duplicated.

The processor of the bus coupling module can now use alternatively its memory areas of the user memory filed on PROM, or the RAM memory areas in the RAM-Pack, as instructed.

The RAM-Pack can be plugged at any time into an active bus coupling module. Operation of the bus coupling module is in no way disturbed, it continues to work with its memory areas in the user memory filed on PROM. The RAM-Pack is inactive.

When the RAM-Pack is plugged in, an entry is made in status register 248 (RAM-Pack in place) and the status register is transferred as event.

If the supply voltage of the bus coupling module is switched off while the RAM-Pack is plugged in and active, the RAM-Pack is re-activated in the initializing phase on reconnection of the voltage (provided it was not removed and plugged in again while the bus coupling module was deenergized).

In the first processing cycle after reconnection of the supply voltage, the memory areas of the RAM-Pack are used immediately.

If an active RAM-Pack is withdrawn by mistake, switchover to the corresponding PROM memory areas of the bus coupling module is initiated immediately.

FUNCTION OF THE RAM-PACK IN CONNECTION WITH THE BUS COUPLING MODULE

In connection with the bus coupling module, the RAM-Pack is used as a PROM substitute.

It allows "on-line" changing of the limit and threshold values filed in the user memory for the analog value entry.

Other information filed in the user memory, e.g. information concerning measuring range expansion in the case of analog outputs or bit multiplex tables with binary outputs, cannot be changed using the RAM-Pack. It is always read from the user PROM.

COOPERATION 88 QTO2, 83 RP01 AND CONTROL SYSTEM OPERATOR STATION

Cooperation between the bus coupling module, the RAM-Pack and the control system operator station is carried on by means of instructions which are transferred to the bus coupling module via the control system operator station.

For this purpose, the control system operator station is equipped with a suitable transfer program.

The following instructions are of importance in connection with the RAM-Pack:

- Switch over to RAM-Pack
- Switch back to user PROM
- Copy the limit value list and threshold value list from the user PROM into the RAM-Pack
- Allocate job memory
- Copy job memory into target memory

The bus coupling module responds to all instructions by transferring the status register 248 as an event (exception "Copy job memory into target memory". If the job memory is allocated, no event is initiated for the status register).

The instruction functions are generally handled by the transfer program, thereby allowing automatic operation.

Documentation update

The PROCONTROL system enables the operator to ascertain and display the actual system configuration from a control system operator station.

This identification is realized for the modules of station-bus, as there are input, output, control and coupling modules by means of the respective module program.

Furthermore the operator can inform himself, from the control system operator station, about the allocation of the IO-bus to IO-bus modules.

To this end, the bus coupling module keeps a so-called bus allocation list which contains an entry for every function unit projected or connected to the IO-bus.

The bus allocation list only serves to document the current IO-bus allocation to input and output modules; more detailed information is specific to the input and output modules and therefore included in additional lists.

The entry contains the corresponding IO-bus address with address extension and any other information by which the current configuration with input and output modules is documented.

Basically, the bus allocation list serves for purposes of diagnosis and documentation update. Data output takes place according to the marshalling list in the user memory.

The following information is provided by the entries.

Output modules:

- IO-bus output module neither available nor projected under this IO-bus address.
- Output module available, but not projected.
- Output module projected, but not available.
- Output module projected and available.

The presence of modules is confirmed by the acknowledgement signal.

Input modules:

- During initialization no IO-bus input module available under this IO-bus address.
- Input module available, but was connected up only after initialization.
- Input module was available during initialization, but no longer transfers data.
- Input module was present during initialization and transfers data.

DOCUMENTATION UPDATE OF IO-BUS INPUT MODULES

The allocation of the IO-bus to input modules is recorded by the bus coupling module in the following two lists, which are both necessary for unambiguous documentation updating of input modules.

- Bus allocation list
- Specification code list

While the existence of an input module is documented by the bus allocation list, information on the transmitter type and the version is given by the specification code list; the version can only be given if specification telegrams are transferred by the input module.

Special case:

81 EB10

No versions can be distinguished here since the module transfers no specification telegrams.

SR modules, WF modules and output modules at the IO-bus

Although these modules do not transfer specification telegrams (address extension = 0), their module type code is entered in the specification code list.

The address extension informs the bus coupling module whether an IO-bus input module transfers specification telegrams.

- Address extension = 0:

Input module transfers no specification telegrams (81 EB10).

The bus coupling module presumes automatically that the input module transfers binary values.

All output modules have address extension 0.

- Address extension = 1:

Input module transfers data and specification telegrams. (All other IO-bus input modules)

The specification telegrams have the following structure:

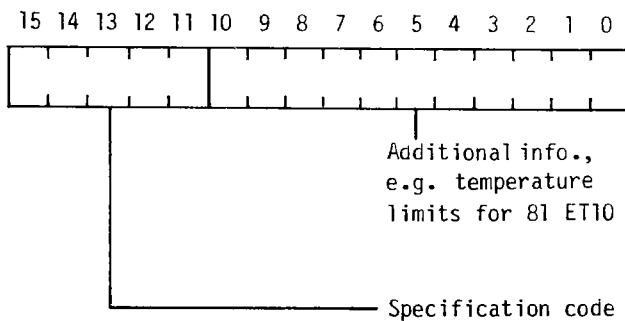

Bits 11-15 of the specification telegrams transferred by the IO-bus modules are entered in the specification code list.

The specification code corresponds to the type of transmitter described in the module descriptions of the IO-bus modules, and serves to update documentation and to tell the processing program how the relevant value is to be processed.

Specification codes of the individual IO-bus input modules:

15	14	13	12	11	10	9	8	7	6	5	4	3	2	1	0
0	0	0	0	0											
0	0	0	0	0	1										
0	0	0	0	1	0										
0	0	0	0	1	1										
0	0	1	0	0											
0	0	1	0	1											
0	0	1	1	0											
0	0	1	1	1											
0	1	0	0	0											
0	1	0	0	1											
0	1	0	1	0											
0	1	0	1	1											
0	1	1	0	0											
0	1	1	0	1											
0	1	1	1	0											

- 0: not used (station-bus modules)
- 1: 81 ET10/R0100, thermocouple NiCr-Ni
- 2: 81 ET10/R0100, thermocouple Fe-CuNi
- 3: 81 ET10/R0100, thermocouple PtRh-Pt
- 4: not used
- 5: 81 ET10/R0200, thermocouple NiCr-Ni
- 6: 81 ET10/R0200, thermocouple Fe-CuNi
- 7: 81 ET10/R0200, thermocouple PtRh-Pt
- 8: 81 EA10/R0100, analog signals 0 mA ... 20 mA
- 9: 81 EA10/R0200, analog signals 4 mA ... 20 mA
- 10: 81 EA10/R0300, analog signals 0 V ... 10 V
- 11: 81 EW10/R0100/R0200/R0300/R0400, PT100
- 12: 81 EW10/R0500, potentiometric transmitter
- 13: 81 ET10/R0100, thermocouple Cu-CuNi *
- 14: 81 ET10/R0100, thermocouple Cu-CuNi *

* When this code is set, the bus coupling module outputs an error annunciation (no linearization list available for Cu-CuNi).

15 14 13 12 11 10 9 8 7 6 5 4 3 2 1 0

--	--	--	--	--	--	--	--	--	--	--	--	--	--	--	--

0	1	1	1	1
---	---	---	---	---

15: 81 EZ10/R1010/R1210, counter word width 32 bits

1	0	0	0	0
---	---	---	---	---

16: 81 EZ10/R1010/R1210, counter word width 16 bits

1	0	0	0	1
---	---	---	---	---

17: 81 EB11/R0200,
Binary signals with binary value output

1	0	0	1	0
---	---	---	---	---

18: not used

1	0	0	1	1
---	---	---	---	---

19: 81 EB11/R0100,
Binary signals without binary value output

1	0	1	0	0
---	---	---	---	---

20: 81 AB10 (projected) *

1	0	1	0	1
---	---	---	---	---

21: 81 AA10 (projected) *

1	0	1	1	0
---	---	---	---	---

22: 83 SR10/R0100 control module (projected) *

1	0	1	1	1
---	---	---	---	---

23: 83 SR10/R0200 control module (projected) *

1	1	0	0	0
---	---	---	---	---

24: 81 EA11/R0100, analog signals 0 mA ... 20 mA

1	1	0	0	1
---	---	---	---	---

25: 81 EA11/R0200, analog signals 4 mA ... 20 mA

1	1	0	1	0
---	---	---	---	---

26: 81 EA11/R0300, analog signals 0 V ... 10 V

1	1	0	1	1
---	---	---	---	---

27: 83 SR11/R0200 control module (projected) *

1	1	1	0	0
---	---	---	---	---

28: 87 WF10 control room coupling module (proj.) *

1	1	1	0	1
---	---	---	---	---

29: not used

1	1	1	1	0
---	---	---	---	---

30: not used

1	1	1	1	1
---	---	---	---	---

31: not used

* Although these modules do not transfer specification telegrams, these codes are reserved for them.

DOCUMENTATION UPDATE OF IO-BUS OUTPUT MODULES

The allocation of the IO-bus to output modules is recorded by the bus coupling module in the following two lists, which are both necessary for unambiguous documentation updating of output modules.

- Bus allocation list
- Marshalling list

Since output modules, unlike input modules, cannot be identified on the basis of a transferred or not transferred specification telegram, the documentation update for the output modules is carried out using the marshalling list in connection with the bus allocation list which contains the current allocation to output modules.

The information projected in the marshalling list for the documentation update gives the desired status.

It is now determined, by reference to the bus allocation list, whether an output module actually acknowledges reception of data under the specified IO-bus addresses.

DOCUMENTATION UPDATE OF THE BUS COUPLING MODULE

The bus coupling module is updated by an entry at register address 210; it is here identified by decimal figure "6".

Annunciation functions

Disturbances can be signalled by the bus coupling module in the following ways:

- Visual disturbance annunciation on the module by the light-emitting diode on the front which emits a steady light in the event of a disturbance.
- Annunciation via bus line SST of the station-bus.

The annunciation functions on the module and to the station-bus are initiated by the diagnostic procedure described below.

Any hardware and software errors in the modules and the connected IO-bus are detected by cyclic diagnosis.

Two diagnosis registers are available for error specification:

- Diagnosis register 246: Standard diagnosis register
- Diagnosis register 211: IO-bus-specific diagnosis register, in which module-specific errors associated with the IO-bus are entered.

For status messages, a status register is available:

- Status register 248: Standard status register

ANNUNCIATIONS ON THE MODULE

Three red and one green light-emitting diodes are arranged on the module front.

- Light-emitting diode ST

The red light-emitting diode ST emits steady light when the module identifies an incorrect function internally or in its area.

- Light-emitting diode STEA

The red light-emitting diode STEA emits steady light, when a disturbance is detected on the IO-bus or inside the IO-bus-specific part of the bus coupling module, which prevents data communication via the IO-bus.

The red light-emitting diode STEA emits flashing light for approx. 4 seconds after the supply voltage has been connected; by this, the bus coupling module indicates that the IO-bus starts to get ready for work.

- Light-emitting diode SIM

The red light-emitting diode SIM emits steady light when the RAM-Pack 83 RPO1 is active or when at least one output value is simulated.

- Light-emitting diode UD

The green light-emitting diode UD emits steady light when the operating voltage UD is present to the module.

ANNUNCIATION FUNCTIONS TO THE STATION-BUS

For disturbance annunciation on the station-bus, the general disturbance signal is output on the station-bus via bus line SST.

In response to this signal, the diagnosis registers are read by the control system operator station for evaluation purposes.

DIAGNOSTIC PROCEDURES

The diagnostic cycle interrupts the processing cycle in progress if a period of 200 ms to 400 ms has elapsed since the last diagnostic cycle.

The following module-specific operations are performed, and the results are filed in the diagnosis registers:

- Functional testing of the IO-bus including the IO-bus adaption of the bus coupling module.

- Refreshing of the bus allocation list and of the corresponding auxiliary lists in steps.

- Evaluation of disturbances, annunciation and entry in the diagnosis registers.

The bus coupling module can generate 2 diagnosis telegrams which are filed in the shared memory under register addresses 246 and 211.

The diagnosis registers can be read out via the control system operator station; they contain information on the status of the bus coupling module and the IO-bus.

Data contents of the diagnosis register under register address 211:

- The data register provides information on the status of data communication on the IO-bus, the IO-bus itself and the IO-bus adaption.

Data contents of the diagnosis register under register address 246:

- The diagnosis register provides information on the status of the data communication with the station-bus and on the internal status.

- The diagnosis register contains the standard diagnostic data of the station-bus modules with module address GA = 1 ... 58.

Data contents of the status register under register address 248:

- The status register contains the standard status messages of the station-bus modules with module address GA = 1 ... 58.

Format of the diagnosis telegram under register address 246:

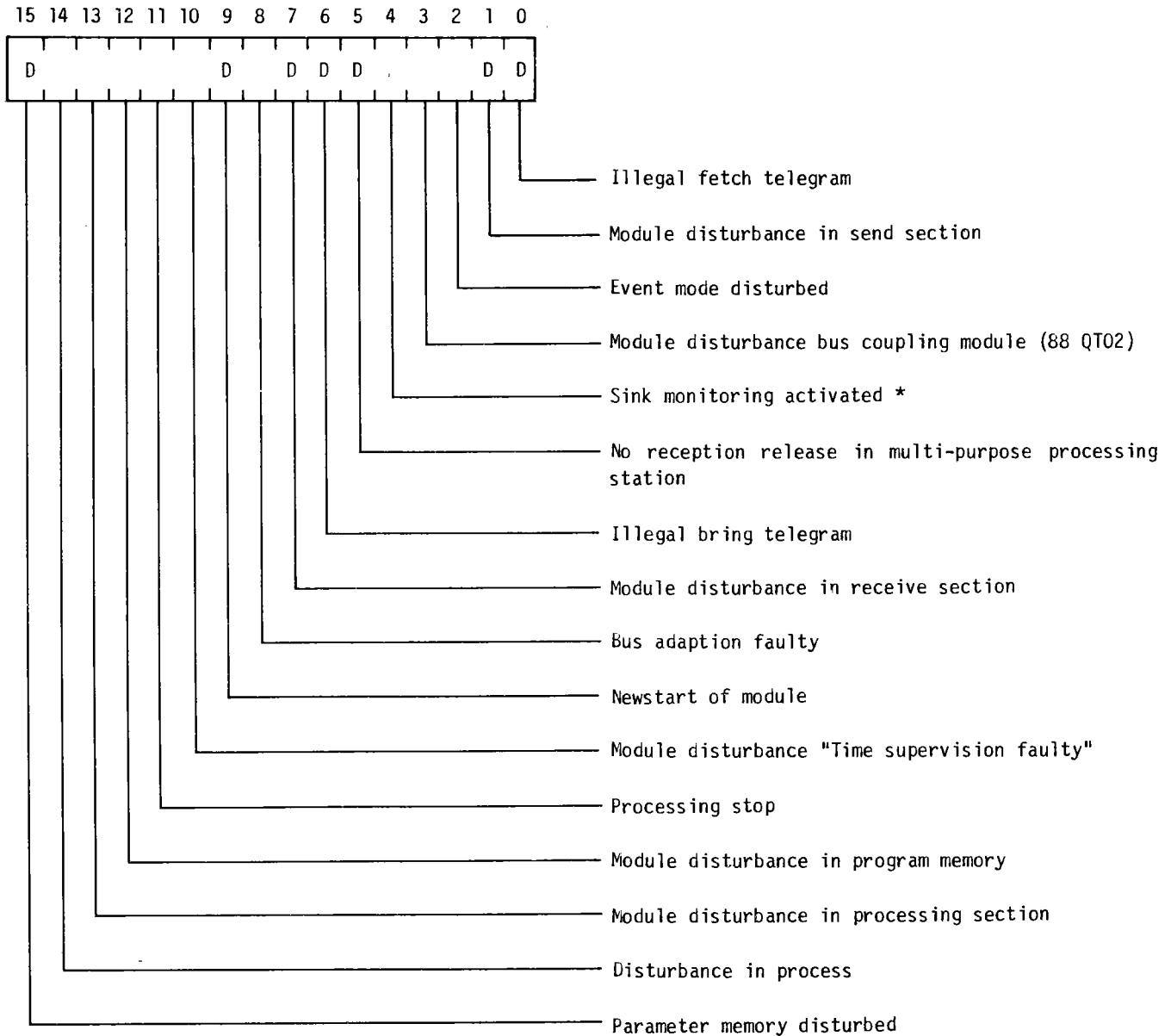

The bit positions marked with "D" transfer dynamic diagnosis signals.

Dynamic: Signal is present until the next one is transferred, even if the cause of the signal has disappeared.

Static: Signal is present only for the duration of its cause.

If bit 3 of diagnosis register 246 is set, diagnosis register 211 contains the relevant specification of the disturbance.

* The diagnosis signal "Sink time monitoring" is also set when a telegram is output directly. For instance, if the input module at the IO-bus whose data are to be output again to the IO-bus, fails.

The affected module is indicated by error code 14 in diagnosis register 211.

Format of the diagnosis telegram under register address 211:

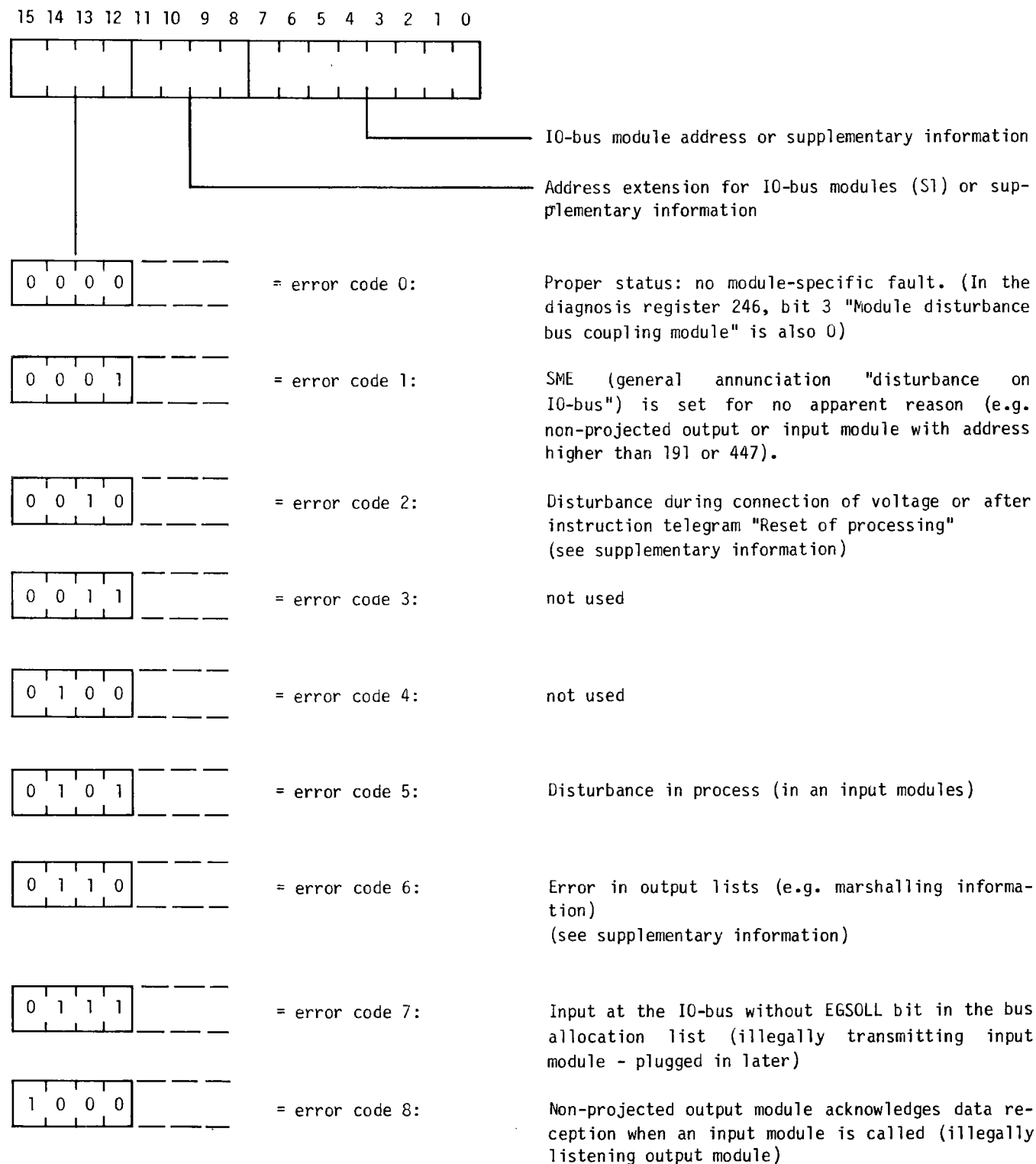

15 14 13 12 11 10 9 8 7 6 5 4 3 2 1 0



IO-bus module address or supplementary information

Address extension for IO-bus modules (S1) or supplementary information

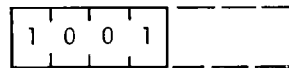

= error code 9:

Input module transfers specification telegram with non-plausible supplementary information, e.g. illegal measuring range in 81 ET10

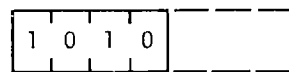

= error code 10:

Input module transfers specification telegram with undefined specification code

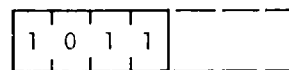

= error code 11:

Allocation of an IO-bus address to a projected output module and an input module (both modules with same address extension)

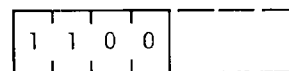

= error code 12:

Double allocation of an IO-bus address to input modules with different address extensions

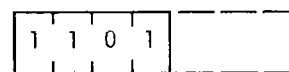

= error code 13:

No acknowledgement of data reception in the case of a projected output module (see description control switch S2:1)

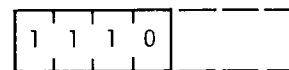

= error code 14:

No IO-bus telegrams (disturbed input module)



= error code 15:

IO-bus or 88 QT02 IO-bus adaption disturbed (see supplementary information)

The structure of the diagnosis telegram under register address 211 varies according to the error code.

In connection with the corresponding error code, mostly the address of the affected IO-bus function unit is transferred in bit 0 to bit 11 of the diagnosis telegram.
(If several function units are disturbed, the highest function unit address is used).

Error codes 2, 6 and 15 are exceptions. Here the diagnosis telegram contains supplementary information instead of the IO-bus module address and the address extension.

With error code 2 set, the diagnosis telegram under register address 211 has the following meaning:

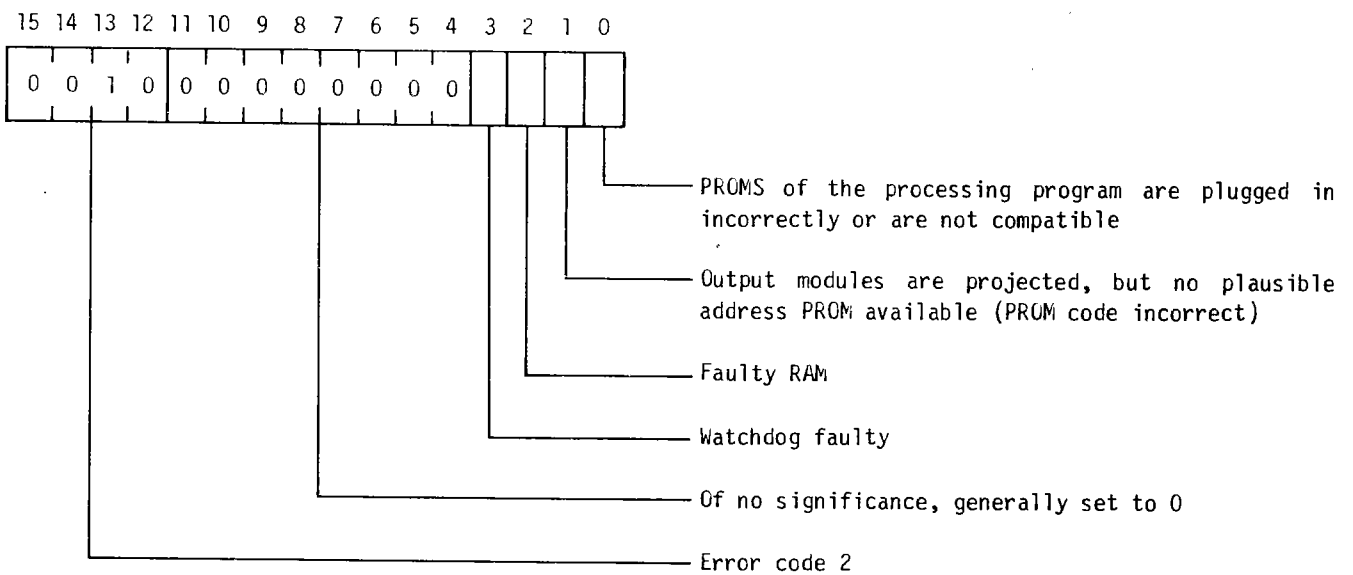

In connection with error code 6, the diagnosis telegram under register address 211 has the following meaning:

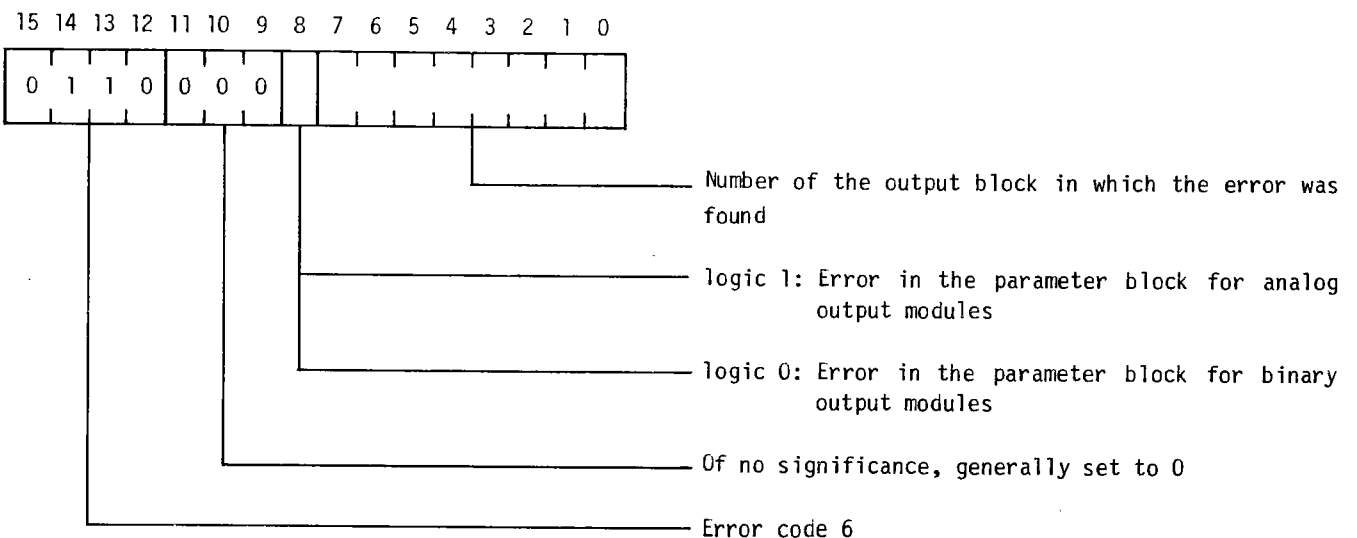

With error code 15 set, the diagnosis telegram under register address 211 has the following meaning:

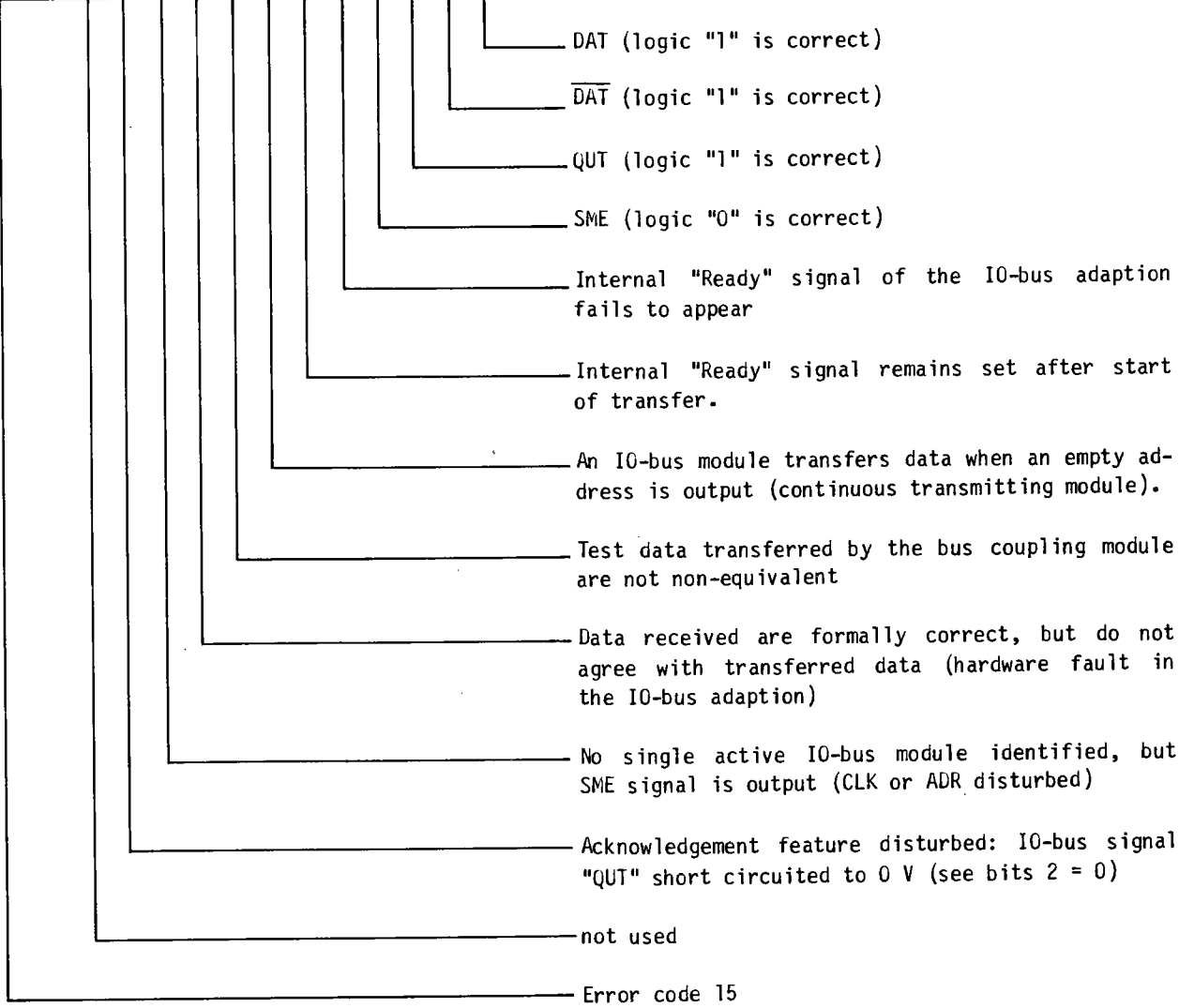
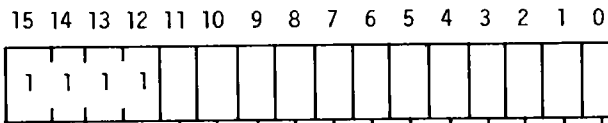

Format of the status telegram under register address 248:

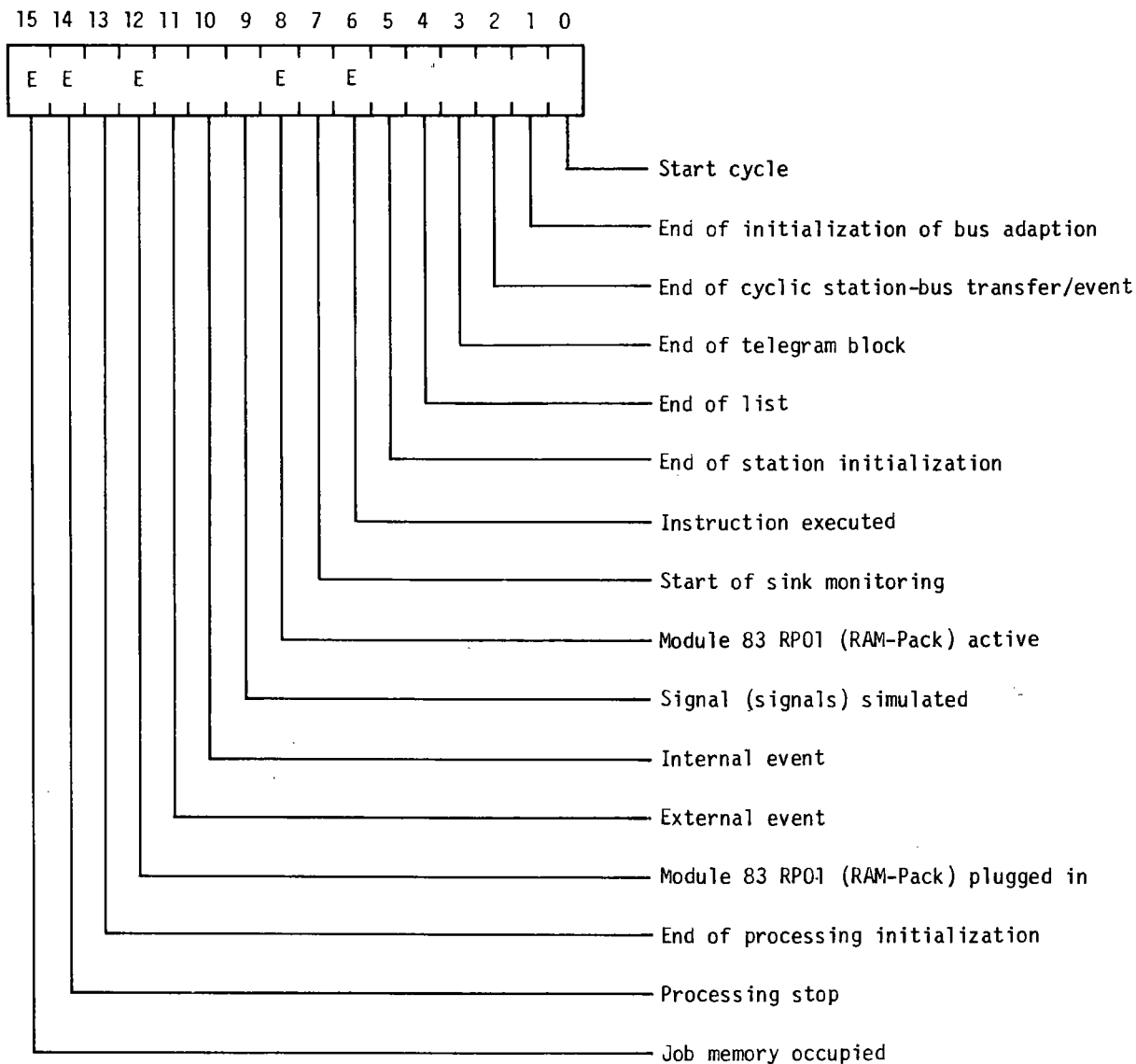

The bit positions marked with "E" are transferred as event.

Setting of the module

Two configuration switches and 1 pushbutton switch are available on the module.

Both configuration switches S2 and S3 are provided on the printed circuit board (2) (lower printed circuit board).

The protect mounted reset pushbutton switch S1 can be operated through a cut-out in the module front.

It is marked by RST imprinted on it.

MEANING OF RESET PUSHBUTTON SWITCH

By operation of the reset pushbutton switch S1 arranged on the module front, the bus allocation list is updated completely, e.g. after plugging in or withdrawal of one or more input modules.

MEANING OF CONFIGURATION SWITCHES

Only the contacts S2.1 to S2.4 of the 8-pole configuration switch are wired. Setting of the contacts S2.5 to S2.8 is optional.

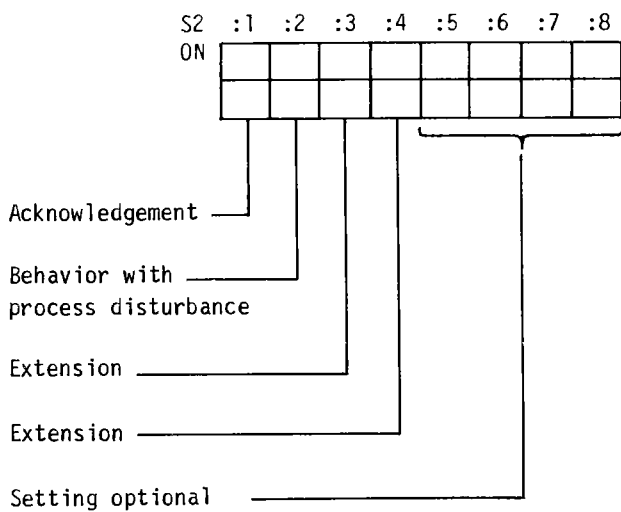

The contacts S2:2 to S2:4 are intended for module extensions. The contacts S2:5 to S2:8 are not wired on printed circuit board.

The switch contact S2:1 can be used to decide whether the acknowledgement signals of the IO-bus output modules are to be evaluated or not.

The switch has to be set to position OFF to allow identification of the IO-bus output modules from the central operating desk.

Acknowledgement signals are evaluated:

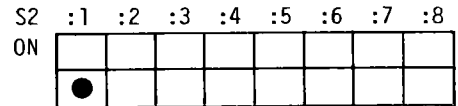

Acknowledgement signals are not evaluated:

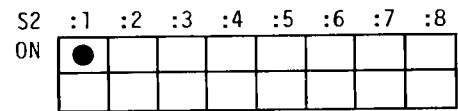

Switch contact S2:2 can be used to vary the behaviour in the event of disturbances in the process affecting analog values.

Disturbance in the process affecting analog values is signalled, limit value calculation is not performed:

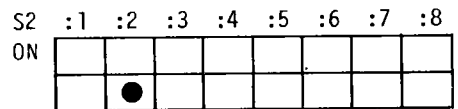

Disturbance in the process affecting analog values is not signalled, limit value calculation is performed:

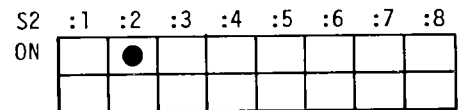

The contacts of switch S2 provided for module extension have to be transferred to position OFF:

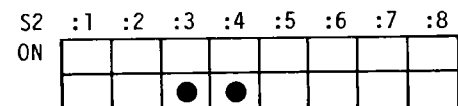

Switch S3 is in the following position:

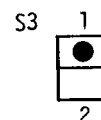

Functional diagram

MODULE VERSION 88 QT02-E/R1013

Terminal designations: the module consists of 2 printed circuit boards (see "Mechanical design").

Printed circuit board (1) with connector X3 incorporates the processor and memory units as well as the standard interface SS to the station-bus.

Printed circuit board (2) incorporates the control function for the IO-bus. It is fitted with connectors X1 and X2, with connector X2 providing the standard interface SEA to the IO-bus and connector X1 providing the standard interface SRP to RAM-Pack 83 RP01.

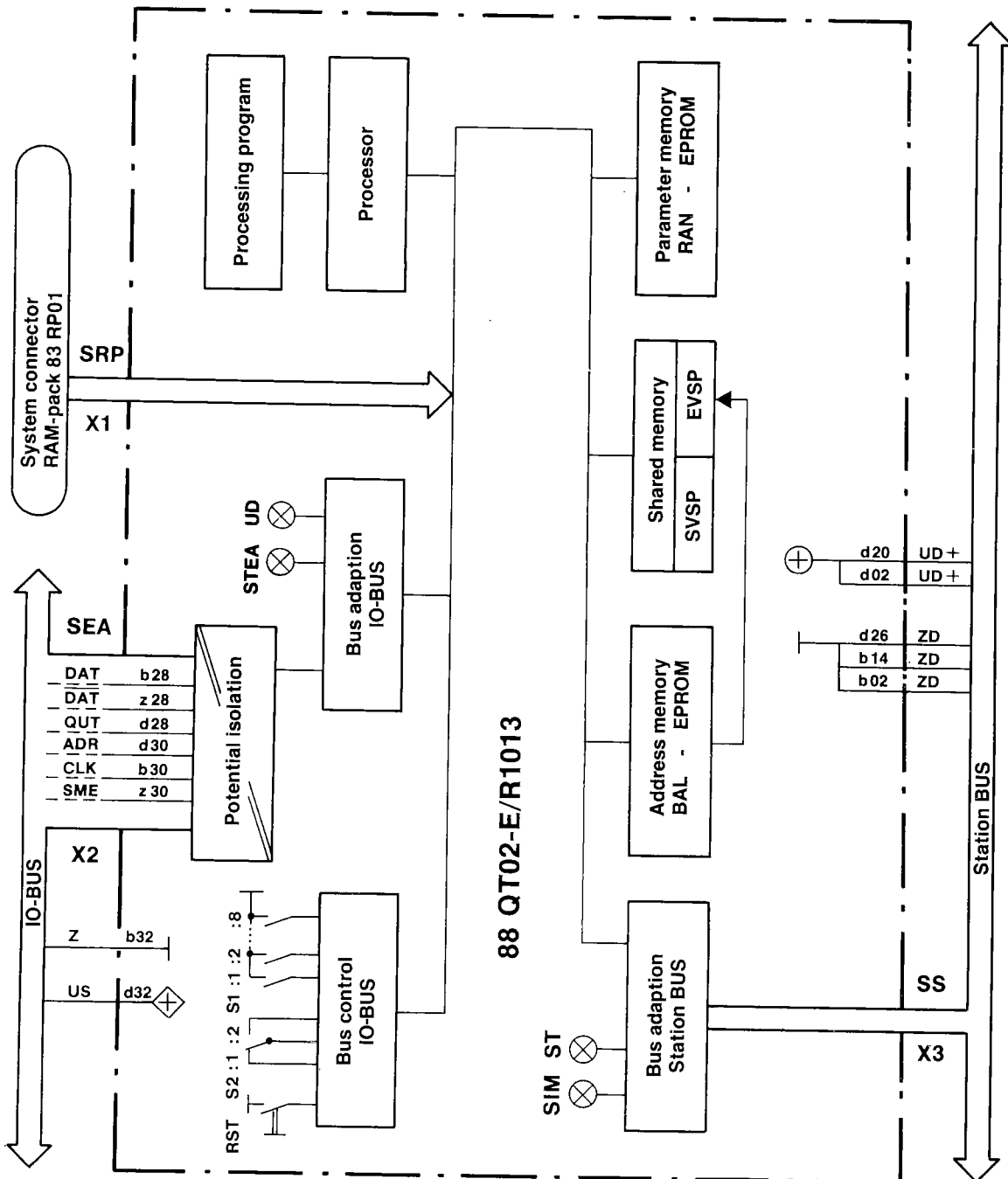

Connection diagram

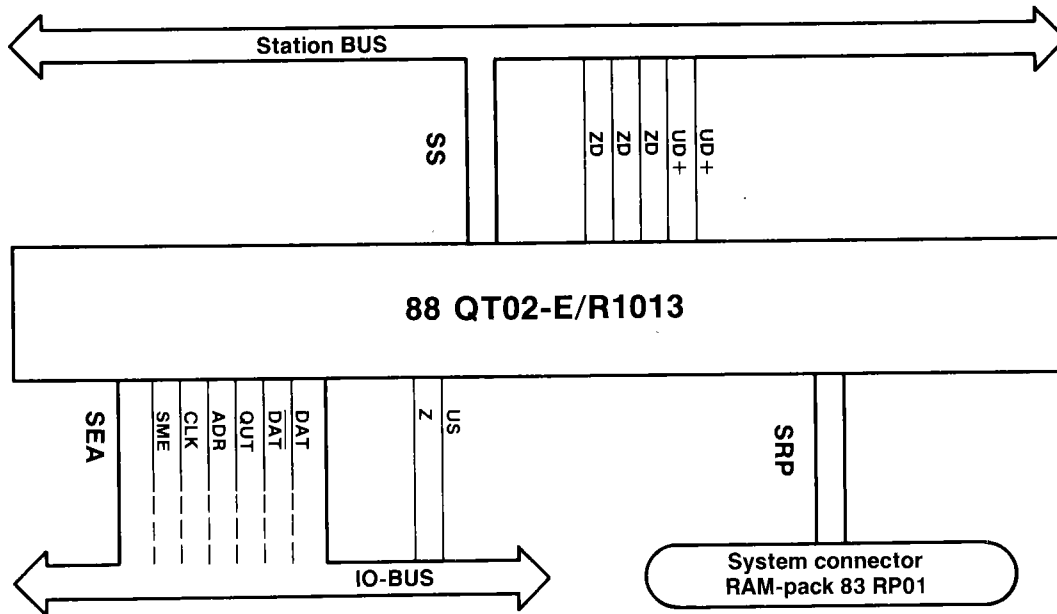

Mechanical design

Board size: 6 U, 2 T, 160 mm deep

View of connector side:

Connector: to DIN 41 612

1 x for station-bus connection
48-pole,
edge-connector type F
(connector X3)

1 x for IO-bus connection
48-pole,
edge-connector type F
(connector X2)

Plug: 1 x for RAM-Pack 83 RP01
25-pole, GRV1908151P125
(connector X1)

Weight: approx. 0.71 kg



Both printed circuit boards are connected mechanically and electrically with each other.

POSITIONS OF THE SWITCHES, CONNECTORS AND VISUAL
DISPLAYS ON THE MODULE FRONT

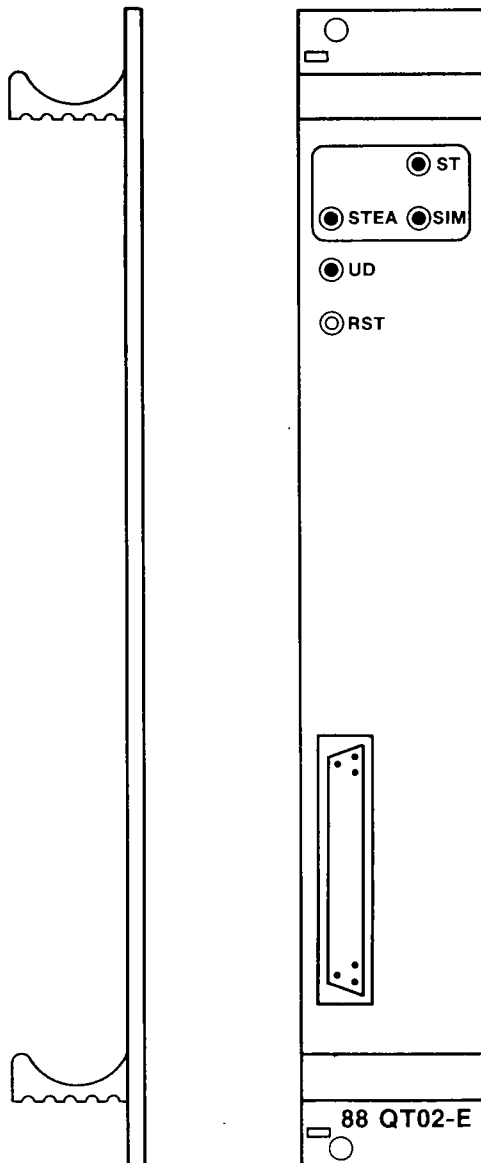

- ST Disturbance in the area of the bus coupling module
- STEA Disturbance in data communication with the IO-bus
(emits flashing light for about 4 s while the ready status is being established)
- SIM Simulation of IO-bus outputs or RAM-Pack active
- UD Operating voltage check
- RST Reset pushbutton for updating of the bus allocation list (S1)

Connection for RAM-Pack 83 RP01

POSITIONS OF THE PLUG-IN MEMORY MODULES AND PLUG-IN JUMPERS ON PRINTED CIRCUIT BOARD (1)

Printed circuit board (1) is the standard printed circuit board for station-bus adaption version R1400.

The printed circuit board incorporates processor units for execution of the module-specific tasks with corresponding memory areas, in particular the send and receive shared memories.

The plug-in jumpers on the printed circuit board can be seen on the diagram below.

The plug-in jumpers have to be installed in accordance with the operating principles description GKWE 705 196 "Bus adaption for station-bus" depending on the components used.

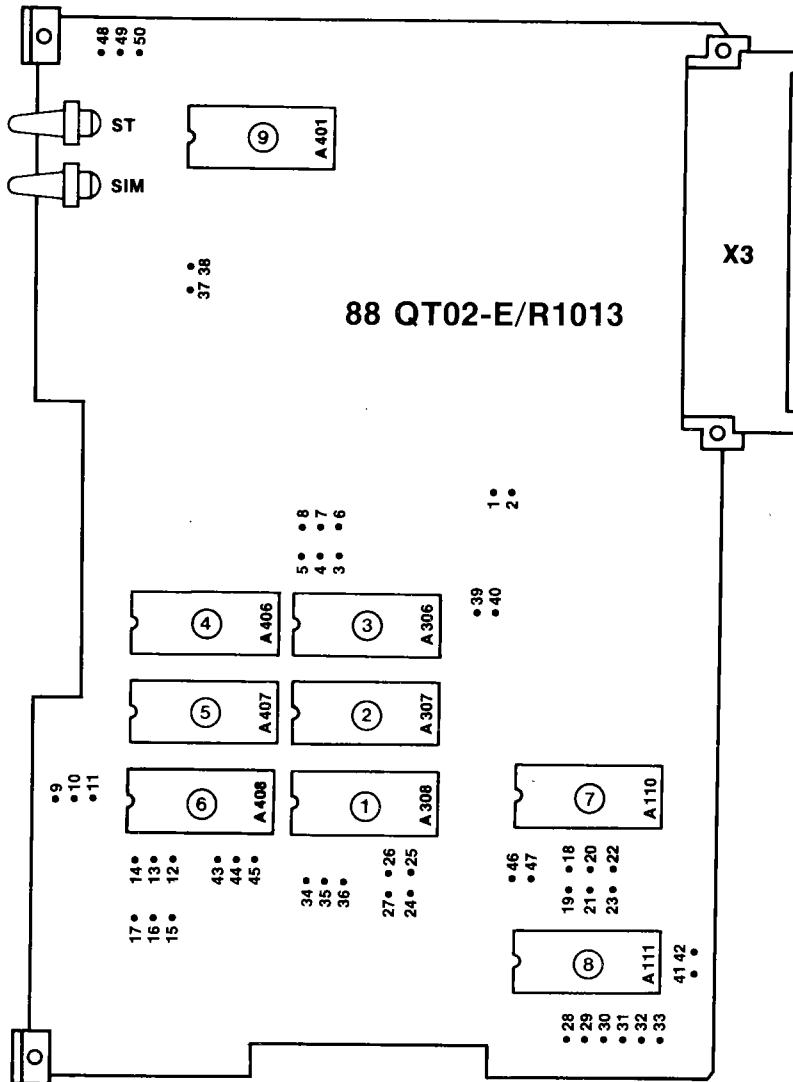

Memory module	Order number (component)	Order number (PROM programmed)
① = A308 (EPROM) Bus program	GJT110034P1	GJR2350801PXXXX
② = A307 (EPROM) Processing program	GJT110034P1	GJR2350802PXXXX
③ = A306 (EPROM) Processing program	GJT110034P1	GJR2350803PXXXX
④ = A406 (EPROM) Processing program	GJT110034P1	GJR2350804PXXXX
⑤ = A407 (EPROM) User memory	GJT110034P1	Customer specific * (Marshalling list - RAN **) (Limit value list - GRE **)
⑥ = A408 (RAM)	----	----
⑦ = A111 (RAM)	----	----
⑧ = A110 (RAM)	----	----
⑨ = A401 (EPROM) User memory	GJT110034P1	Customer specific * (Bus address list - BAL **)

Note: The mounting positions of the components is specified by an imprint on the printed circuit board.
XXXX = position number corresponding to the appropriate revision.

* If no lists are available, an unprogrammed PROM with list header must be plugged in.

** The abbreviations relate to the operating modes of the PDAG through which access can be gained to the lists.

POSITIONS OF THE PLUG-IN MEMORY MODULES, JUMPERS AND SWITCHES ON PRINTED CIRCUIT BOARD (2)

The printed circuit board incorporates the standard interface to the IO-bus SEA with IO-bus adaptation and control.

Location of the bridge on the printed circuit board:

Following jumpers are wired: 1001
1002
1003

Memory module:	Order number: (component)	Order number: (PROM programmed)
⑩ = A309 (RAM)	-----	-----

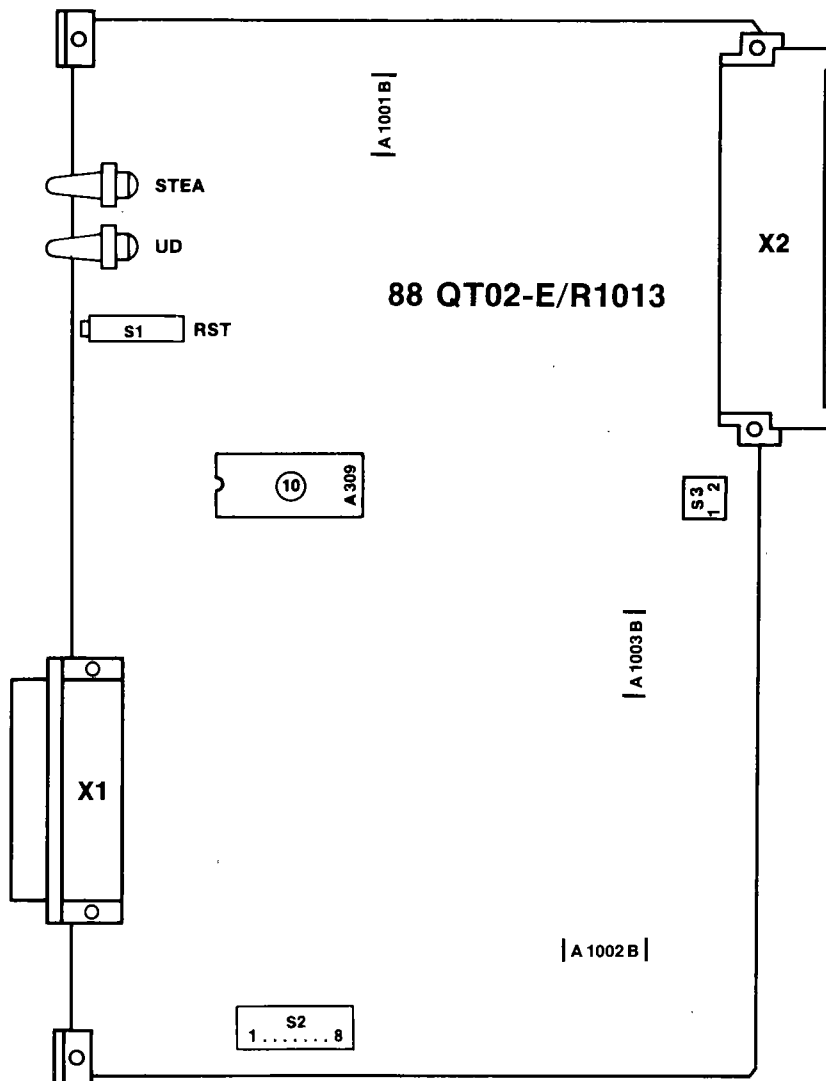

Technical data

In addition to the system data, the following values apply :

POWER SUPPLY STATION BUS SECTION

Operating voltage station-bus section, UD:	5 V
Current consumption of station-bus section, ID:	1.5 A
Power dissipation P_{vtyp} :	7.5 W
Reference potential station-bus section, ZD:	0 V

POWER SUPPLY IO-BUS SECTION

Rated voltage:	19.5 V ... 30 V
Operating voltage of IO-bus section, US:	24 V
Current consumption of IO-bus section, IS:	36 mA
Power dissipation P_{vtyp} :	0.9 W
Reference potential IO-bus Z:	0 V

Adding of the individual values for power dissipation P_{vtyp} gives the total power dissipation of the module.

MODULE INTERFACES

- SRP - Standard interface RAM-Pack 83 RP01, connector X1
- SEA - Standard interface IO-bus, connector X2
- SS - Standard interface station-bus, connector X3

PERMISSIBLE TEMPERATURE RANGES

Operating temperature:	0 °C ... 70 °C
Storage temperature:	-40 °C ... 85 °C

ORDERING DATA

1. Complete module:
 Type designation: 88 QT02-E/R1013 Order number: GJR2342500R1013
2. Memory module: see "Mechanical design".

Technical data are subject to change without notice!



ABB Kraftwerksleittechnik GmbH

P. O. Box 100351, D-68128 Mannheim
Phone (0621) 381 2712, Telefax (0621) 381 4372
Telex 462 411 107 ab d