

---

# Electromagnetic Flowmeter EcoMaster Hygienic FXL4000-DL23

## Operating Instructions

D184B135U02

06.2008

Rev. A

### Manufacturer:

**ABB Automation Products GmbH**

Dransfelder Straße 2

D-37079 Göttingen

Germany

Tel.: +49 551 905-534

Fax: +49 551 905-555

CCC-support.deapr@de.abb.com

© Copyright 2008 by ABB Automation Products GmbH

Subject to change without notice

This document is protected by copyright. It assists the user with the safe and efficient operation of the device. The contents may not be copied or reproduced in whole or in excerpts without prior approval of the copyright holder.

<b>1</b>	<b>Safety</b>	<b>6</b>
1.1	General Safety Information	6
1.2	Intended use	6
1.3	Improper use	7
1.4	Technical limit values	7
1.5	Allowed Fluids	8
1.6	Warranty provision	8
1.7	Labels and symbols	8
1.7.1	Name Plate / Factory Tag	9
1.8	Operator liability	12
1.9	Personnel qualification	12
1.10	Returning devices	12
1.11	Disposal	13
1.11.1	Information on WEEE directive 2002/96/EC (Waste Electrical and Electronic Equipment)	13
1.12	Transport safety information	13
1.13	Installation safety information	13
1.14	Electrical installation safety information	14
1.15	Operating safety information	14
1.16	Safety information for maintenance and inspection	14
<b>2</b>	<b>Design and function</b>	<b>15</b>
2.1	Measuring principle	15
2.2	Design	16
2.3	Device design	16
<b>3</b>	<b>Transport</b>	<b>16</b>
3.1	Inspection	16
3.2	General information on transport	16
<b>4</b>	<b>Installation</b>	<b>17</b>
4.1	General information on installation	17
4.2	Installation Requirements	17
4.2.1	Electrode axis	17
4.2.2	In- and outlet pipe sections	17
4.2.3	Vertical connections	17
4.2.4	Horizontal connections	17
4.2.5	Free inlet or outlet	18
4.2.6	Strongly contaminated fluids	18
4.2.7	Installation of pumps	18
4.2.8	Reducers	18
4.3	Mounting the meter tube	19
4.4	Torque information	20

4.4.1	Wafer unit model DL23W .....	20
4.4.2	Variable process connections for model DL23 .....	20
4.5	Rotating the display .....	21
<b>5</b>	<b>Electrical connection .....</b>	<b>22</b>
5.1	Connection Examples for Peripherals.....	23
5.1.1	Variant 1 (without display) or variant 3 (with display) .....	23
5.1.2	Variant 2 (without display) or variant 4 (with display) .....	23
5.1.3	Variant 5 (with display).....	23
5.2	Ground.....	24
5.2.1	General information on ground connections .....	24
5.2.2	Flowmeter primary with wafer connection.....	24
5.2.3	Ground with conductive PTFE grounding plate .....	26
5.2.4	Flowmeter primary with variable process connection .....	26
<b>6</b>	<b>Startup Operation .....</b>	<b>26</b>
6.1	Preliminary checks prior to start-up.....	26
6.2	Commissioning the unit.....	27
6.2.1	Switching on supply power.....	27
6.2.2	Device configuration.....	27
6.3	Software history.....	30
<b>7</b>	<b>Parameterization.....</b>	<b>31</b>
7.1	Entering data in “short form”.....	31
7.2	Data entry .....	32
<b>8</b>	<b>Error messages .....</b>	<b>36</b>
8.1	Error states and alarms .....	36
8.2	Error messages during operation and with data entry .....	36
<b>9</b>	<b>Maintenance / Repair.....</b>	<b>37</b>
9.1	Maintenance for the flowmeter .....	37
9.2	Cleaning .....	38
9.3	Gaskets .....	38
9.4	Replacing the transmitter .....	38
<b>10</b>	<b>Spare parts list.....</b>	<b>39</b>
10.1	Fuses on the transmitter electronic unit .....	39
10.2	Contact information at ABB Service for spare parts .....	40
10.3	Spare parts for the transmitter .....	40
<b>11</b>	<b>Technical data.....</b>	<b>41</b>
11.1	Measuring accuracy .....	41
11.1.1	Reference conditions per EN 29104 .....	41
11.1.2	Maximum Measurement Error.....	41
11.2	Flowmeter sensor.....	41
11.2.1	General specifications.....	41

---

11.2.2	Material load for variable process connections.....	42
11.2.3	Material load for wafer configuration.....	42
11.3	Transmitter .....	43
11.3.1	General specifications.....	43
<b>12</b>	<b>Appendix .....</b>	<b>44</b>
12.1	Permits and certifications .....	44
12.2	Additional documents .....	47
12.3	Overview of technical design and setting parameters .....	48
<b>13</b>	<b>Index .....</b>	<b>50</b>

## 1 Safety

### 1.1 General Safety Information

The “Safety” chapter provides an overview of the safety aspects to be observed for the operation of the device.

The device is built based on state-of-the-art technology and is operationally safe. It was tested and left the factory in a proper state. The requirements in the manual as well as the documentation and certificates must be observed and followed in order to maintain this state for the period of operation.

The general safety requirements must be complied with completely during operation of the device. In addition to the general information, the individual chapters of the manual contain descriptions about processes or procedural instructions with specific safety information.

Only the observance of all safety information enables the optimal protection of personnel as well as the environment from hazards and the safe and trouble-free operation of the device.

### 1.2 Intended use

This device is intended for the following uses:

- To transmit fluid, pulpy or pasty substances with electrical conductivity.
- To measure the flowrate of the operating volume

The following items are included in the intended use:

- Read and follow the instructions in this manual.
- Observe the technical ratings; refer to the section “Technical limit values”.
- Use only allowed liquids for measurement; refer to the section “Allowed fluids”.

### 1.3 Improper use

The following uses of the device are prohibited:

- Operation as a flexible adapter in piping, e.g., to compensate for pipe offsets, pipe vibrations, pipe expansions, etc.
- Use as a climbing aid, e.g., for assembly purposes.
- Use as a support for external loads, e.g., as a support for pipes, etc.
- Material gain, e.g., by painting over the name plate or adding parts by welding / soldering.
- Material loss, e.g., by drilling the housing.

Repairs, alterations and enhancements or the installation of replacement parts is only permissible as far as described in the manual. Further actions must be verified with ABB Automation Products GmbH. Excluded from this are repairs performed by ABB-authorized specialist shops.

### 1.4 Technical limit values

The device is designed for use exclusively within the stated values on the model plate and within the technical limit values specified in the data sheets.

The following technical limit values must be observed:

- The permissible operating pressure (PS) in the permissible temperature (TS) may not exceed the pressure-temperature ratings.
- The maximum operating temperature may not be exceeded.
- The permitted operating temperature may not be exceeded.
- The housing protection system must be observed.
- The flowmeter sensor may not be operated in the vicinity of powerful electromagnetic fields, e.g., motors, pumps, transformers, etc. A minimum spacing of approx. 1 m (3.28 ft) should be maintained. For installation on or to steel parts (e.g., steel brackets), a minimum spacing of approx. 100 mm (3.94 inch) should be maintained (based on IEC801-2 and IECTC77B).

**1.5 Allowed Fluids**

When measuring fluids, the following points must be observed:

- Fluids may only be used if, based on state-of-the-art technology or the operating experience of the user, it is assured that chemical and physical properties of the components coming into contact with the fluids (signal electrodes, ground electrodes, liners and, possibly, process connections, protective plates or protective flanges) are not affected during the operating life.
- Fluids with unknown properties or abrasive fluids may only be used if the operator can perform regular and suitable tests to ensure the safe condition of the device.
- Observe the information on the name plate.

**1.6 Warranty provision**

A use contrary to the device’s stipulated use, disregarding of this manual, the use of under-qualified personnel as well as unauthorized alterations excludes the manufacturer of liability from any resulting damages. The manufacturer’s warranty expires.

**1.7 Labels and symbols**



**Danger – <Serious damage to health / risk to life>**  
 One of these symbols in conjunction with the “Danger” warning indicates an imminent danger. If it is not avoided, death or serious injury will result.



**Warning – <Bodily injury>**  
 The symbol in conjunction with the “Warning” message indicates a possibly dangerous situation. If it is not avoided, death or serious injury could result.



**Caution – <Slight injuries>**  
 The symbol in conjunction with the “Caution” message indicates a possibly dangerous situation. If it is not avoided, slight or minor injury can result. May also be used for property damage warnings.



**Notice – <Property damage>!**  
 The symbol indicates a possibly damaging situation. If it is not avoided, the product or something in its area can be damaged.



**Important**  
 The symbol indicates operator tips or especially useful information. This is not a message for a dangerous or damaging situation.



### 1.7.1 Name Plate / Factory Tag

The factory tag or name plate can be found at the following locations on the unit housing:

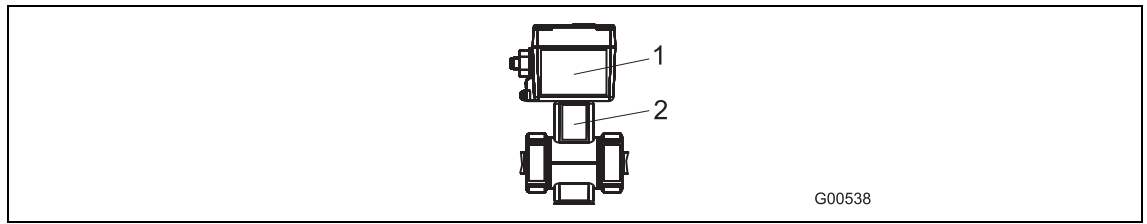

Fig. 1

1 Name plate

2 Factory tag

#### 1.7.1.1 Identifying the device design

1. Identifying the model:

The model number of the device (see no. 1 in the description of the name plates) can be found on the name plate. The connection diagram is included in the section "Electrical connection". Technical data, material load curves, etc., are organized by model in the section "Technical data".

2. Identifying the transmitter design:

The transmitter design can be identified from the name plate.

3. Identifying the software version:

The software version can be displayed when the transmitter is switched on.

1.7.1.2 Name plate

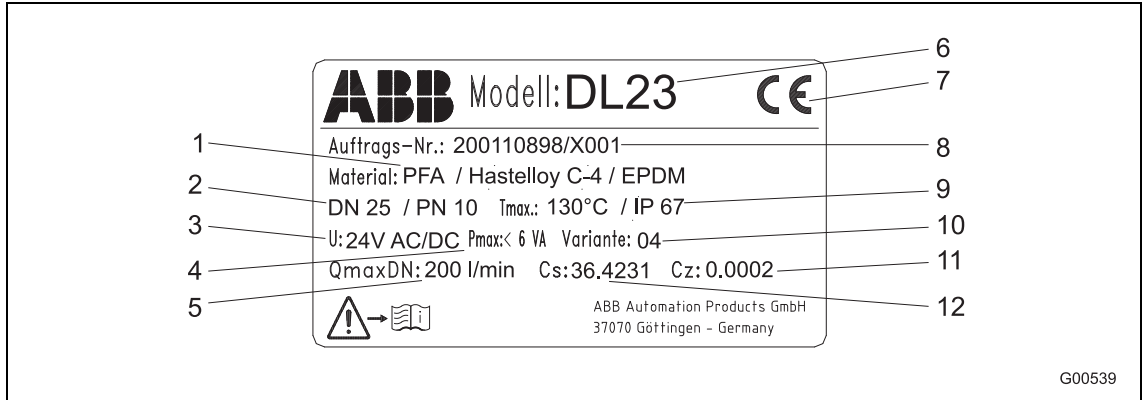

Fig. 2

- 1 Measuring tube lining / Electrode material / Gasket
- 2 Nominal size / Nominal pressure
- 3 Supply power
- 4 Power
- 5 Max. flowrate at v = 10 m/s
- 6 Model no. of device
- 7 CE mark (EC conformity)
- 8 Order no.
- 9 Max. fluid temperature / Protection class
- 10 Variant (see table below)
- 11 Cz calibration factor "zero point"
- 12 Cz calibration factor "range"

Variant	Description
Variant 01	Pulse / contact output
Variant 02	Pulse / contact output + current output
Variant 03	Pulse / contact output + display
Variant 04	Pulse / contact output + current output + display
Variant 05	Pulse / contact output + contact input + display

**1.7.1.3 Factory Tag**

The factory tag is located on the flowmeter sensor housing. If the pressure equipment is subject to the PED (see section 3 para. 3 PED 97/23/EC), two labels are required:

**Pressure equipment subject to PED**

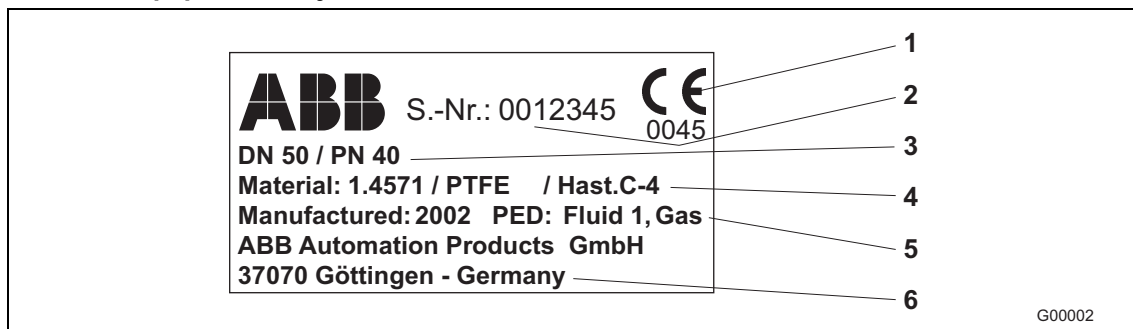

Fig. 3

- |  |  |
|--|--|
| <ul style="list-style-type: none"> <li>1 CE mark (with number of labeled location) to confirm the device meets the requirements of pressure equipment directive 97/23/EC.</li> <li>2 Serial number for identification of the pressure equipment by the manufacturer.</li> <li>3 Nominal size and nominal pressure rating of pressure equipment.</li> </ul> | <ul style="list-style-type: none"> <li>4 Flange material, liner material and electrode material (wetted parts).</li> <li>5 Year of manufacture and specification of fluid group as per the pressure equipment directive (PED). Fluid group 1 = hazardous liquids, gaseous.</li> <li>6 Manufacturer of the pressure equipment.</li> </ul> |
|--|--|

**Pressure equipment outside the applicable range of the PED**



Fig. 4

The factory tag contains most of the specifications included on the plate described above with the following differences:

- There is no CE mark because the pressure equipment, as per section 3 para. 3 of the PED, is outside the applicable range of the pressure equipment directive 97/23/EC.
- The reason for the exception is specified in section 3 para. 3 of the PED. The pressure equipment is categorized as SEP (= sound engineering practice).



**Important**

If the factory tag is not present, the device is not in compliance with directive 97/23/EC. The exception applies for water, power and connected equipment accessories in accordance with guideline 1/16 of sec. 1 para. 3.2 of the pressure equipment directive.

### 1.8 Operator liability

Before the use of corrosive and abrasive measuring fluid, the operator must clarify the resistance of all parts that come into contact with the fluid to be measured. ABB will gladly support you with the selection, however, cannot accept any liability.

The operators must strictly observe the applicable national regulations in their countries with regards to installation, function tests, repairs, and maintenance of electrical devices.

### 1.9 Personnel qualification

The installation, commissioning and maintenance of the device may only be carried out through trained specialist personell authorized by the plant operator. The specialist personnel must have read and understood the manual and comply with its instructions.

### 1.10 Returning devices

Use the original packaging or a suitably secure packaging for returning the device for repair or for recalibration. Include the properly filled out return form (see attachment) with the device.

According to EC guidelines for hazardous materials, the owner of hazardous waste is responsible for its disposal or must observe the following regulations for its shipping:

All delivered devices to ABB Automation Products GmbH must be free from any hazardous materials (acids, alkali, solvents, etc.).

Rinse out and neutralize hazardous materials from all hollow spaces such as between meter tube and housing. These activities must be confirmed in writing using the return form.

## 1.11 Disposal

ABB Automation Products GmbH actively promotes environmental consciousness and has an operational management system in accordance with DIN EN ISO 9001:2000, EN ISO 14001:2004 and OHSAS 18001. Our products and solutions should have minimum impact on the environment and persons during manufacture, storage, transport, use and disposal.

This includes the environmentally friendly use of natural resources. Through its publications ABB conducts an open dialog with the public.

This product/solution is manufactured from materials that can be reused by specialized recycling companies.

### 1.11.1 Information on WEEE directive 2002/96/EC (Waste Electrical and Electronic Equipment)

This product/solution is not subject to the WEEE directive 2002/96/EC and relevant national laws (e.g., ElektroG in Germany).

Dispose of the product/solution directly in a specialized recycling facility and do not use the municipal garbage. Only privately used products may be disposed of in the municipal garbage according to the WEEE directive 2002/96/EC. Proper disposal prevents negative effects on people and the environment, and supports the reuse of valuable raw materials.

If it is not possible to dispose of old equipment properly, ABB Service can accept and dispose of returns for a fee.

## 1.12 Transport safety information

Observe the following instructions:

- Depending on the device, the center of gravity may not be in the center of the equipment.

## 1.13 Installation safety information

Observe the following instructions:

- The flow direction must correspond to the direction indicated on the device, if labeled.
- Comply with the maximum torque for all flange connections.
- The devices must be installed without mechanical tension (torsion, bending).
- Install wafer units with coplanar counter flanges.
- Only install devices for the intended operating conditions and with suitable seals.
- Secure the flange bolts and nuts against pipeline vibrations.

### 1.14 Electrical installation safety information

The electrical connection may only be performed by authorized specialists according to the electrical plans.

Comply with electrical connection information in the manual. Otherwise, the electrical protection can be affected.

Ground the measurement system according to requirements.

### 1.15 Operating safety information

During operation with hot fluids, contact with the surface may result in burns.

Aggressive fluids may result in corrosion and abrasion of the parts that come into contact with the medium. As a result, pressurized fluids may escape prematurely.

Due to wear on the flange seal or process connection gaskets (e.g., aseptic threaded pipe connections, Tri-Clamp, etc.), a pressurized medium may escape.

When using internal flat gaskets, these can become embrittled through CIP/SIP processes.

### 1.16 Safety information for maintenance and inspection



#### **Warning - Potential damage to parts!**

The electronic components of the printed circuit board can be damaged by static electricity (observe ESD guidelines).

Make sure that the static electricity in your body is discharged before touching electronic components.

When the housing is open, EMC protection is limited.

Corrective maintenance work may only be performed by trained personnel.

- Depressurize the device and adjoining lines or containers before removing the device.
- Check whether hazardous materials are used as materials to be measured before opening the device. Residual amounts of hazardous material may still be present in the device and could escape when the device is opened.
- As far as provided in the scope of the operational responsibility, check the following items through a regular inspection:
  - the pressure-carrying walls / lining of the pressure device
  - the measurement-related function
  - the leak tightness
  - the wear (corrosion)

## 2 Design and function

### 2.1 Measuring principle

Measurements performed by the electromagnetic flowmeter are based on Faraday's law of induction. A voltage is generated in a conductor when it moves through a magnetic field.

This principle is applied to a conductive fluid in the measuring tube through which a magnetic field is generated perpendicular to the flow direction (see schematic).

The voltage induced in the fluid is measured by two electrodes located diametrically opposite each other. This signal voltage  $U_E$  is proportional to the magnetic induction  $B$ , the electrode spacing  $D$  and the average flow velocity  $v$ .

Considering that the magnetic induction  $B$  and the electrode spacing  $D$  are constant values, a proportionality exists between the signal voltage  $U_E$  and the average flow velocity  $v$ . From the equation for calculating the volume flowrate, it follows that the signal voltage is linearly proportional to the volume flowrate:  $U_E \sim q_v$ .

The induced voltage is converted by the transmitter to standardized, analog and digital signals.

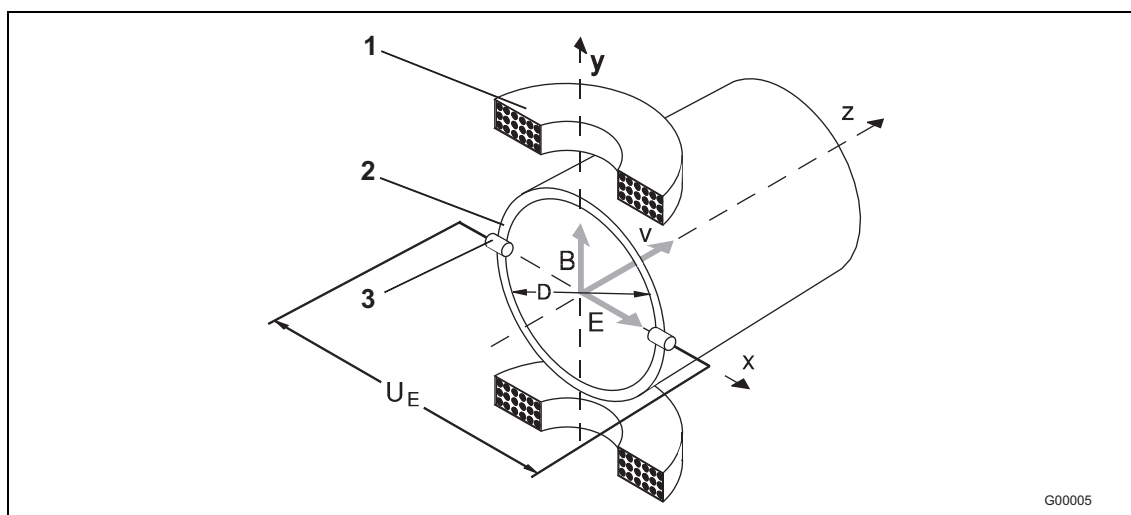

Fig. 5: Electromagnetic flowmeter schematic

- 1 Magnet coil
- 2 Measuring tube in electrode plane
- 3 Signal electrode
- $U_E$  Signal voltage
- $B$  Magnetic induction
- $D$  Electrode spacing
- $v$  Average flow velocity
- $q_v$  Volume flow

$$U_E \sim B \cdot D \cdot v$$

$$q_v = \frac{D^2 \pi}{4} \cdot v$$

$$U_E \sim q_v$$

**2.2 Design**

An electromagnetic flowmeter system consists of a flowmeter primary and a transmitter. In the compact design, the flowmeter and transmitter comprise a single unit.

**2.3 Device design**

The  $\mu$ P transmitter and flowmeter primary comprise a single mechanical entity.

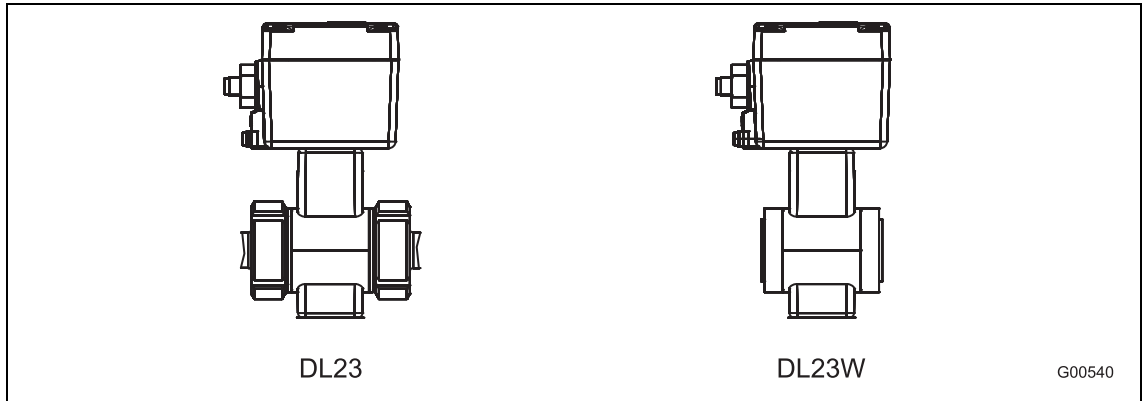

Fig. 6

The compact design is available in stainless steel housing.

- Model FXL4000-DL23 / -DL23W

**3 Transport**

**3.1 Inspection**

Check the devices for possible damage that may have occurred during transport. Damages in transit must be recorded on the transport documents. All claims for damages must be claimed without delay against the shipper and before the installation.

**3.2 General information on transport**

Observe the following when transporting the device to the measurement site:

- The center of gravity may not be in the center of the device.



## 4 Installation

### 4.1 General information on installation

The following points must be observed for the installation:

- The meter tube must always be completely full.
- The flow direction must correspond to the identification if present.
- The maximum torque for all flange connections must be complied with.
- The devices must be installed without mechanical tension (torsion, bending).
- Wafer design flowmeters with coplanar counter flanges may only be installed with suitable seals.
- Use only gaskets made from a compatible material for the fluid and fluid temperatures.
- Gaskets must not extend into the flow area since possible turbulence could affect the accuracy of the devices.
- The pipelines may not exert any unallowable forces or torques on the device.
- Do not remove the plugs in the connectors until you are ready to install the electrical cable.
- Make sure the gaskets for the housing cover are seated properly. Carefully seal the cover. Tighten the cover fittings.
- Do not expose the transmitter to direct sunlight or provide for appropriate sun protection where necessary.
- When selecting the installation site, make sure that moisture cannot penetrate the terminal housing or transmitter compartment.
- Make sure the signal cable connectors are plugged in and tightened properly to ensure IP 67 protection class.

### 4.2 Installation Requirements

#### 4.2.1 Electrode axis

Electrode axis (1) as level as possible or rotated max. 45°.

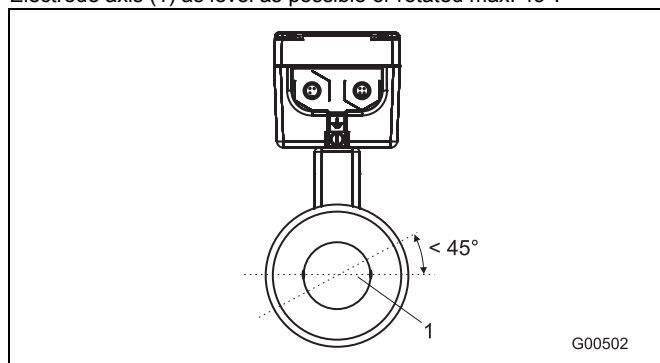

Fig. 7

#### 4.2.2 In- and outlet pipe sections

Straight inlet section	Straight outlet section
≥ 3 x DN	≥ 2 x DN

DN = Flowmeter primary size

- Do not install fittings, manifolds, valves, etc., directly in front of the meter tube (1).
- Butterfly valves must be installed so that the valve plate does not extend into the flowmeter primary.
- Valves or other turn-off components should be installed in the outlet pipe section (2).
- For compliance with the measuring accuracy, observe the inlet and outlet pipe sections.

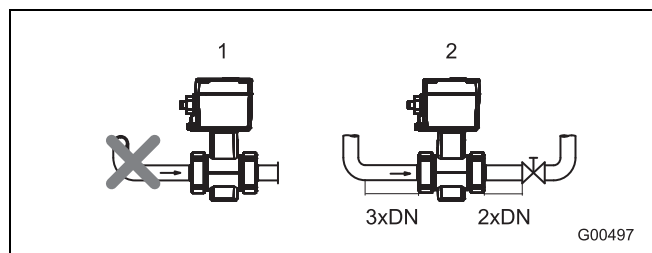

Fig. 8

#### 4.2.3 Vertical connections

- Vertical installation for measurement of abrasive fluids, flow preferably from below to above, with max. flow velocity: 3 m/s.

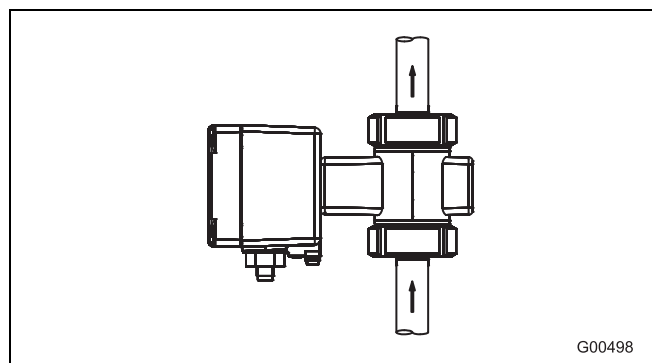

Fig. 9

#### 4.2.4 Horizontal connections

- The meter tube must always be completely full.
- Provide for a slight incline of the connection for degassing.

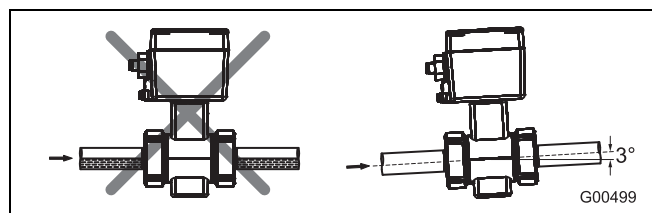

Fig. 10

## Installation

### 4.2.5 Free inlet or outlet

- Do not install the flowmeter at the highest point or in the drain-off side of the pipeline. The flowmeter runs empty and air bubbles can form (1).
- Provide for a siphon fluid intake for free inlets or outlets so that the pipeline is always full (2).

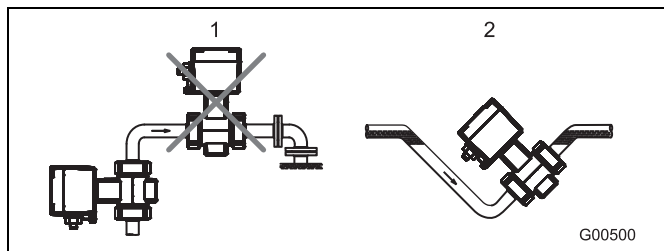

Fig. 11

### 4.2.6 Strongly contaminated fluids

- For strongly contaminated fluids, a bypass connection according to the figure is recommended so that operation of the system can continue to run without interruption during the mechanical cleaning.

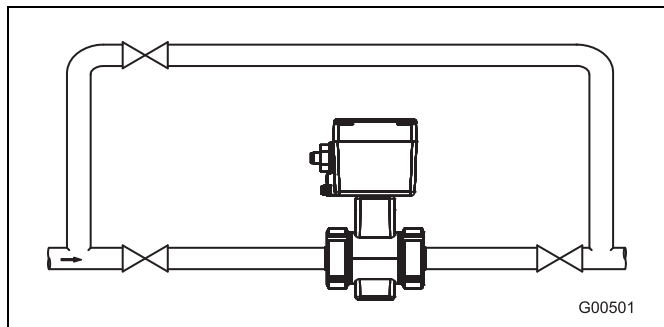

Fig. 12

### 4.2.7 Installation of pumps

- For flowmeter primaries that are installed near pumps or other vibration-generating equipment, the use of mechanical snubbers is mandatory.

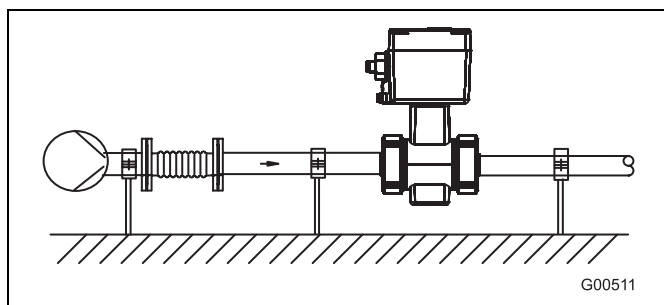

Fig. 13

### 4.2.8 Reducers

Determine the pressure drop due to use of flanged reducers (1):

- Calculate the diameter ratio  $d/D$ .
- Determine the flow velocity based on the flow range nomograph (Fig. 15).
- Read the pressure drop on the Y-axis in Fig. 15.

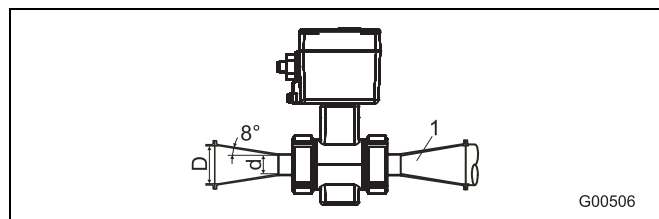

Fig. 14

- $D$  = Inside diameter of the pipeline  
 $d$  = Inside diameter of the flowmeter  
 $v$  = Flow velocity (m/s)  
 $\Delta p$  = Pressure drop (mbar)

### Nomograph for pressure drop calculations

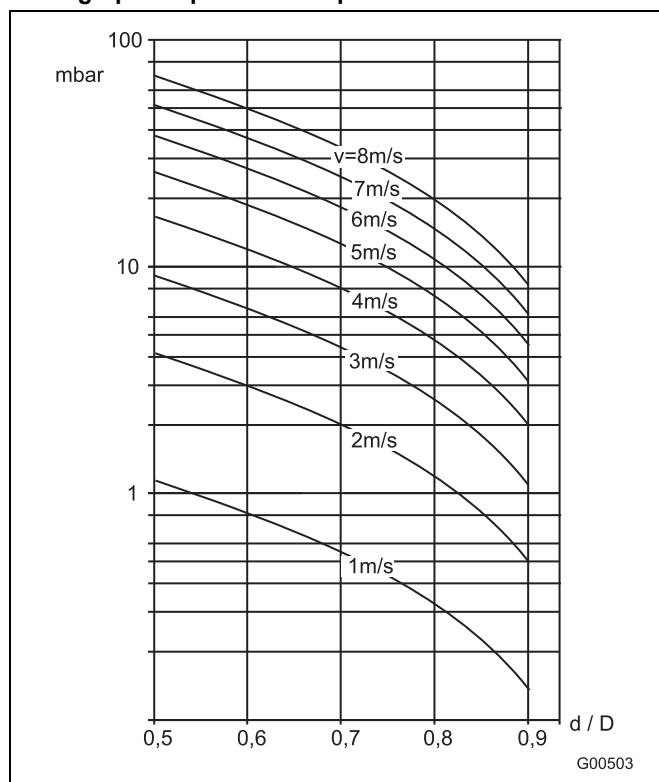

Fig. 15

**4.3 Mounting the meter tube**

The meter can be installed at any location in a pipeline under consideration of the installation conditions.



**Warning - Potential damage to device!**

Use of graphite with the process connection gaskets is prohibited. In some instances, an electrically conductive coating may form on the inside of the measuring tube.

Vacuum shocks in the pipelines should be avoided to prevent damage to the liners. Vacuum shocks can destroy the meter.

1. Remove protective plates, if present, to the right and left of the measuring tube. To prevent possible leakage, make sure that the liner on the flange is not cut or damaged.
2. Position the meter tube coplanar and centered between the pipes.
3. Install gaskets between the surfaces of the device and counter flange.



**Important**

For best results, make sure the flowmeter primary gaskets fit concentrically with the measuring tube.

4. Use the appropriate screws for the holes as per the section "Torque information".
5. Slightly grease the threaded nuts.
6. Tighten the nuts in a crosswise manner as shown in the figure. Observe the torque values specified under "Torques".

First tighten the nuts to 50% of maximum torque, then to 80% and finally on the third time tighten to the maximum. Do not exceed the max. torque.

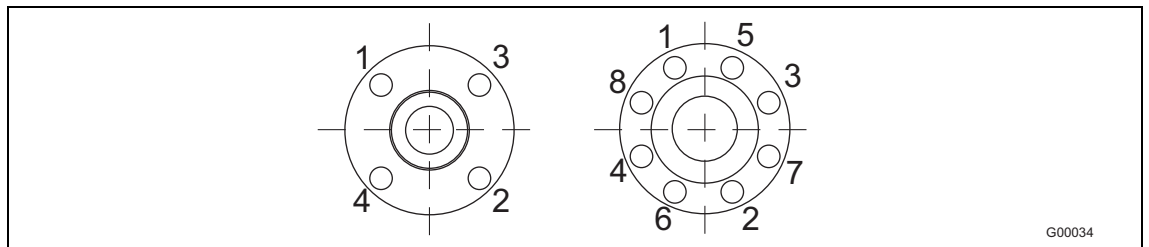

Fig. 16

4.4 Torque information

4.4.1 Wafer unit model DL23W

Meter size DN		Pressure PN	Screws	Maximum tightening torque in Nm
mm	Inch			
10	3/8" 1)	40	4 x M12	7
		CL150	4 x M12	upon request
		CL300	4 x M12	upon request
15	1/2"	40	4 x M12	7
		CL150	4 x M12	upon request
		CL300	4 x M12	upon request
20	3/4"	40	4 x M12	11
		CL150	4 x M12	upon request
		CL300	4 x M16	upon request
25	1"	40	4 x M12	15
		CL150	4 x M12	upon request
		CL300	4 x M16	upon request
32	1 1/4"	40	4 x M16	26
		CL150	4 x M12	upon request
		CL300	4 x M16	upon request
40	1 1/2"	40	4 x M16	33
		CL150	4 x M12	upon request
		CL300	4 x M20	upon request
50	2"	40	4 x M16	46
		CL150	4 x M16	upon request
		CL300	8 x M16	upon request
65	2 1/2"	16	8 x M16	30
		CL150	4 x M16	upon request
80	3"	16	8 x M16	40
		CL150	4 x M16	upon request
100	4"	16	8 x M20	67
		CL150	8 x M16	upon request

1) Connection flange ASME = DN15 (1/2")

4.4.2 Variable process connections for model DL23

Meter size DN		Maximum tightening torque in Nm
mm	inch	
10	3/8"	8
15	1/2"	10
20	3/4"	21
25	1	31
32	1 1/4"	60
40	1 1/2"	80
50	2	5
65	2 1/2"	5
80	3	15
100	4	14

4.5 Rotating the display

Depending on the installation position, the display can be rotated to enable horizontal readings.

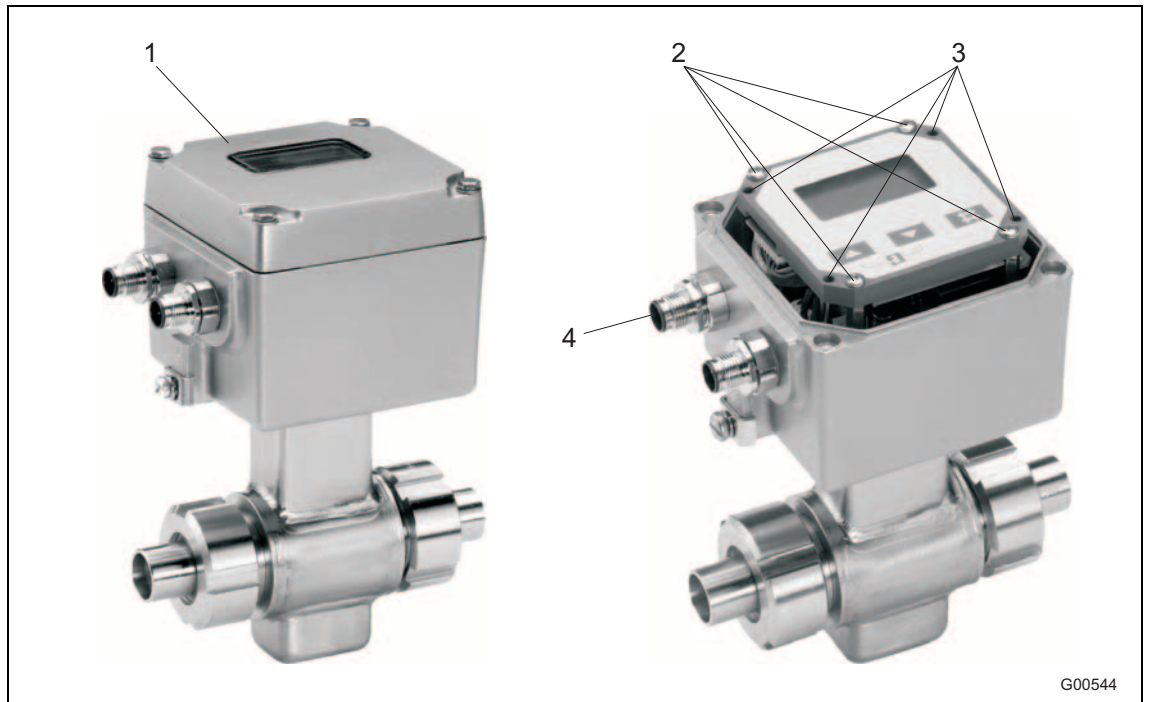

Fig. 17: Display unit



**Warning - Potential damage to parts!**

The electronic components of the printed circuit board can be damaged by static electricity (observe ESD guidelines).

Make sure that the static electricity in your body is discharged before touching electronic components.

When the housing is open, EMC protection is limited.

1. Switch off supply power (e.g., remove the left plug (4)).
2. Screw off housing cover (1).
3. Remove Phillips screws (2).
4. Replace Phillips screws (3).
5. Pull off the display, rotate 90° to the left or right and reinstall.
6. Tighten screws for display and then attach housing cover with screws.
7. If the flow direction indicators in the display do not match the actual flow direction, the parameter “Directional display” should be changed from “normal” to “inverse”.



**Important**

Do not place the housing cover on the inspection glass (risk of scratching).

Check that the gaskets are properly seated when sealing the housing cover. Otherwise, the protection class IP 67 is not maintained.

## 5 Electrical connection

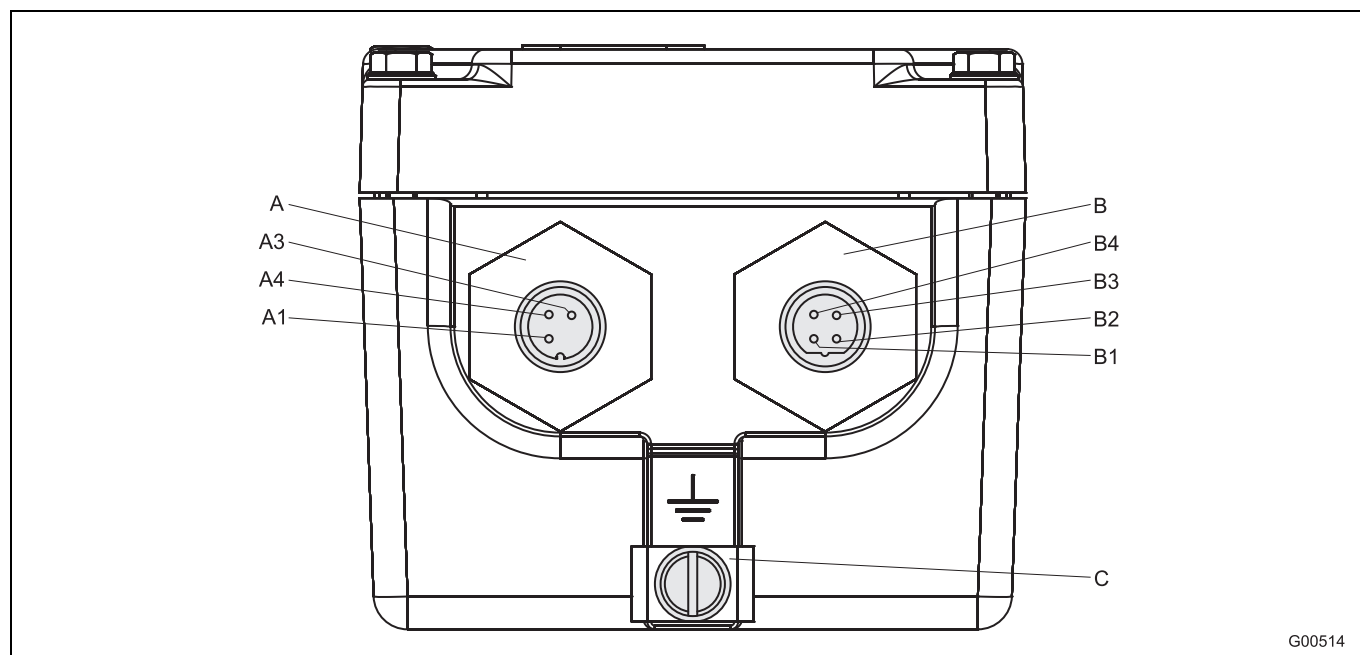

Fig. 18

A Plug for supply power, via 3-pin connector / A-coded (model: Lumberg RKWT4-3-224)

A1 brown, supply power + 24 V AC / DC

A3 blue, supply power GND

A4 black, functional ground

B Plug for signal input/output (assignments are order-specific), connected via 4-pin connector / B-coded (model: Lumberg RKWT4B-225)

C Functional ground



### Important

If a functional ground is connected to the plug (A4) along with the supply power (left plug), the line connected to point C must have the same potential as A4.

If this cannot be ensured, connect the ground to a single point only, either in the plug (A4) or externally on the meter (point C). It is recommended that you connect a functional ground at point C.

Connecting cables / color coding	Variants 01, 03	Variants 02, 04	Variant 05
<b>B1 (brown)</b>	-	Current output (+)	Contact input (+)
<b>B2 (white)</b>	Pulse / contact output (+)	Pulse / contact output (+)	Pulse / contact output (+)
<b>B3 (blue)</b>	-	Current output (-)	Contact input (-)
<b>B4 (black)</b>	Pulse / contact output (-)	Pulse / contact output (-)	Pulse / contact output (-)

**5.1 Connection Examples for Peripherals**

Wiring colors for the following connection examples

- B1 = brown
- B2 = white
- B3 = blue
- B4 = black

**5.1.1 Variant 1 (without display) or variant 3 (with display)**

(pulse output, passive, optocoupler or contact output, passive, optocoupler)

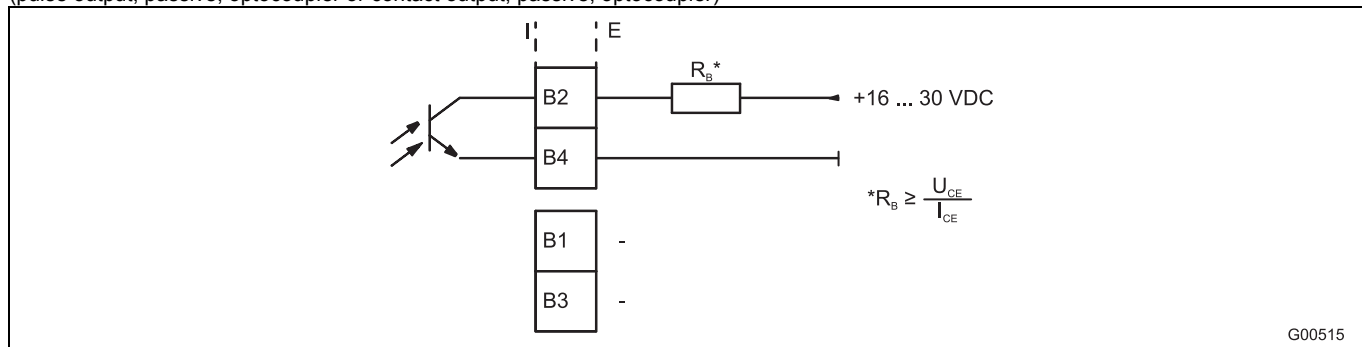

Fig. 19: I = internal, E = external

**5.1.2 Variant 2 (without display) or variant 4 (with display)**

(pulse output, passive, optocoupler and current output 0/4 ... 20 mA or current output, passive, optocoupler and current output 0/4 ... 20 mA)

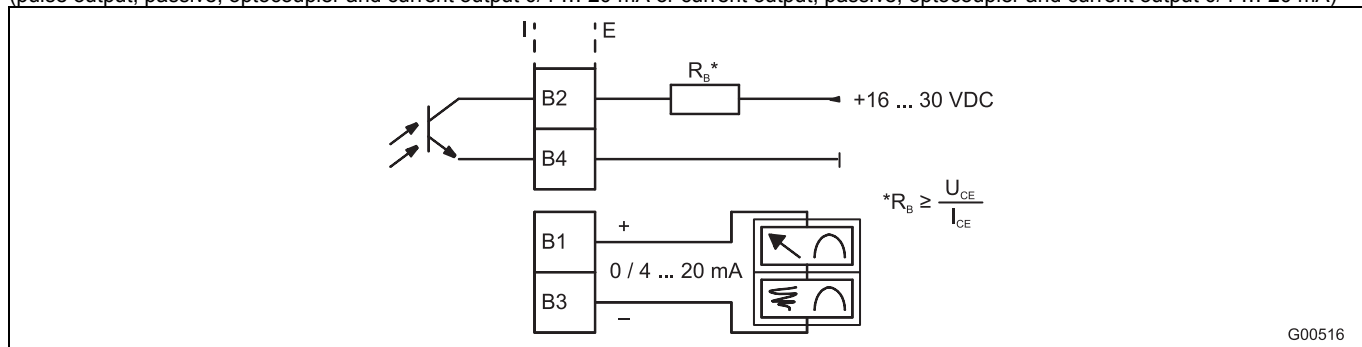

Fig. 20: I = internal, E = external

**5.1.3 Variant 5 (with display)**

(pulse output, passive, optocoupler and contact input, passive, optocoupler or contact output, passive, optocoupler and contact input, passive, optocoupler)

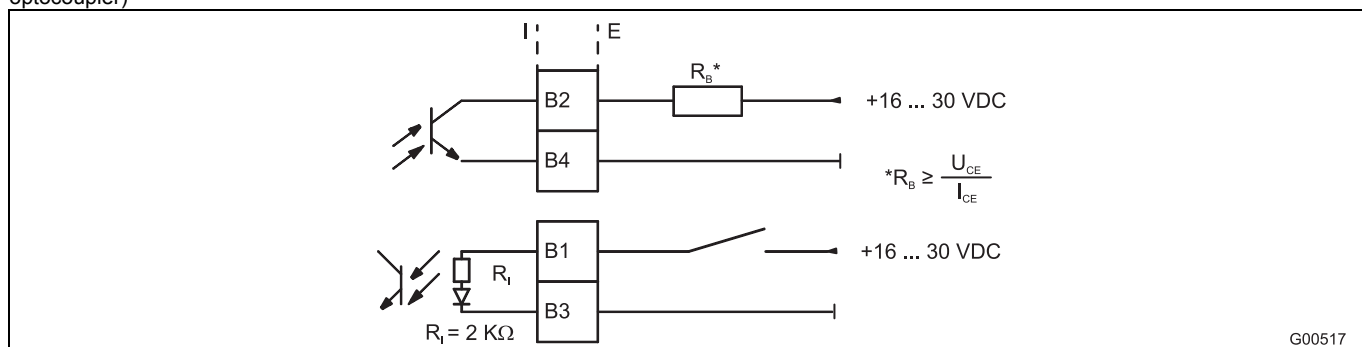

Fig. 21: I = internal, E = external

## 5.2 Ground

### 5.2.1 General information on ground connections

Observe the following items when grounding the device:

- Use the supplied green/yellow cable as a ground wire.
- Connect the ground screw for the flowmeter primary (on the transmitter housing) to the station ground.
- For plastic pipes or pipes with insulating lining, the ground is provided by the grounding plate or grounding electrodes.
- When stray potentials are present, install a grounding plate at the front and back of the flowmeter primary.
- For measurement-related reasons, the potentials in the station ground and in the pipeline should be identical.
- An additional ground via the terminals is not required.



#### Important

If the flowmeter primary is installed in plastic or earthenware pipelines, or in pipelines with an insulating lining, transient current may flow through the grounding electrode in special cases. In the long term, this may destroy the flowmeter primary, since the ground electrode will in turn degrade electrochemically. In these special cases, the connection to the ground must be performed using grounding plates.

### 5.2.2 Flowmeter primary with wafer connection

#### 5.2.2.1 Metal pipe with fixed flanges

1. Insert M6 x 12 threads (1) in the flanges for the pipeline.
2. Secure the ground straps (2) with screws, spring washers and shims as shown in the figure.
3. Use a copper wire (min. 2.5 mm<sup>2</sup>) to establish the ground connection between the flowmeter primary and an appropriate grounding point.

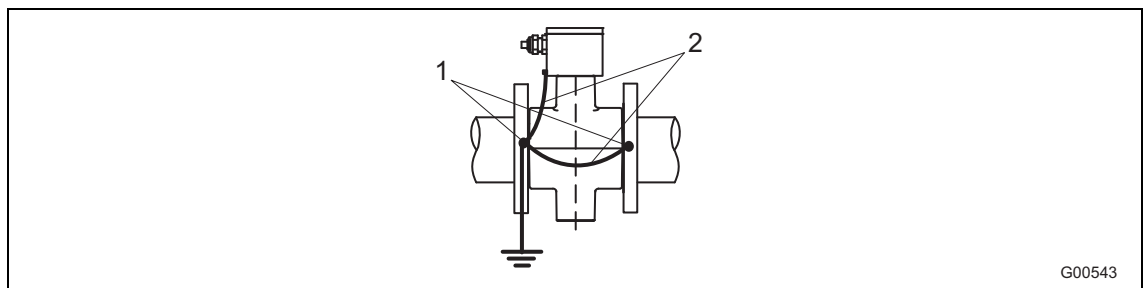

Fig. 22: Wafer design



**5.2.2.2 Metal pipe with loose flanges**

1. Solder the threaded nuts (1) M6 to the pipeline.
2. Secure the ground straps (2) with nuts, spring washers and shims as shown in the figure, and connect to the flowmeter primary with ground connection (3).
3. Use a copper wire (min. 2.5 mm<sup>2</sup>) to establish the ground connection (3) to an appropriate grounding point.

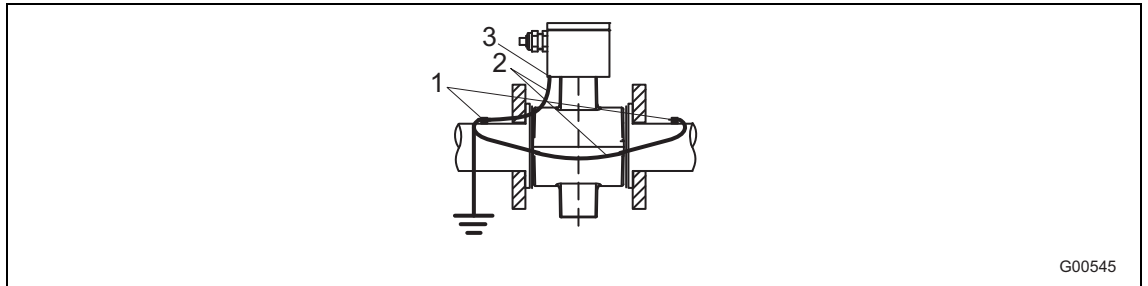

Fig. 23: Wafer design

**5.2.2.3 Non-metallic pipes or pipes with insulating liner**

For plastic pipes or pipes with insulating lining, the ground for the measuring agent is provided by the grounding plate as shown in the figure below or via grounding electrodes that must be installed in the device (option). If grounding electrodes are used, the grounding plate is not necessary.

1. Install the flowmeter primary with grounding plate (2) in the pipeline.
2. Connect the terminal lug for the grounding plate (3) and ground connection on the flowmeter primary (1) with the grounding strap.
3. Use a copper wire (min. 2.5 mm<sup>2</sup>) to establish the ground connection (1) to a suitable grounding point.

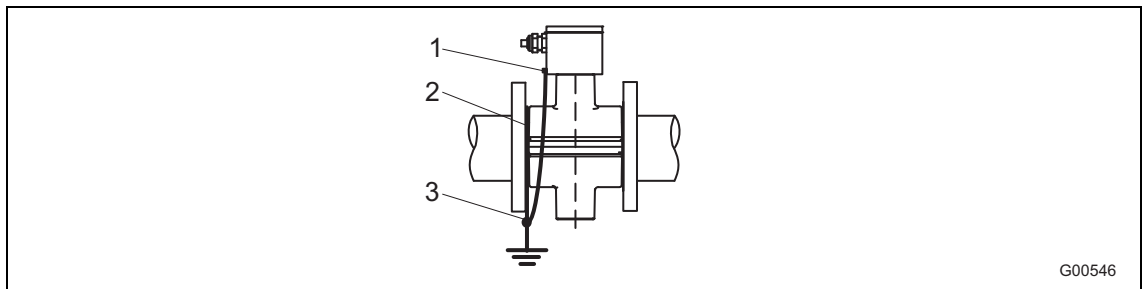

Fig. 24: Wafer design

### 5.2.3 Ground with conductive PTFE grounding plate

For devices with a meter size between DN 10 ... 100, grounding plates made of conductive PTFE are available. These are installed similar to conventional grounding plates.

### 5.2.4 Flowmeter primary with variable process connection

Ground the stainless steel model as shown in the figure. The measuring agent is grounded via the adapter (1) and an additional ground is not required.

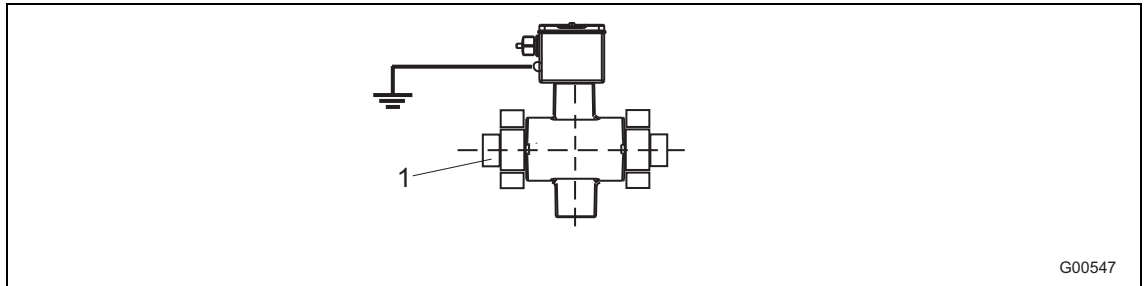

Fig. 25

## 6 Startup Operation

### 6.1 Preliminary checks prior to start-up

The following points must be checked before commissioning:

- The supply power must be switched off.
- The supply power must match information on the name plate.
- The pin assignment must correspond to the connection diagram.
- The unit must be grounded.
- The temperature limits must be observed.

**6.2 Commissioning the unit**

**6.2.1 Switching on supply power**

After switching on the supply power, the display (if in use) shows the current flowrate after a few seconds.

**6.2.2 Device configuration**

The device can be factory calibrated to customer specifications upon request. If no customer information is available, the device is delivered with factory settings.

**6.2.2.1 Configuring the device design without display**

1. Switch off supply power (e.g., remove the supply power plug (4)).
2. Open the housing cover by unscrewing the four screws (see **Fig. 17: Display unit**).
3. Install the display unit (see Fig. 26: Design without display) and attach with four screws (see **Fig. 17: Display unit**).
4. Switching on supply power.
5. Configuring the transmitter (see section 6.2.2.2 "Configuring the design with display").
6. Switching off supply power.
7. Remove the display unit.
8. After configuring the transmitter, carefully seal the housing.
9. Make sure the gaskets for the cover are seated properly. Otherwise, the protection class IP 67 is not maintained.
10. Switching on supply power.

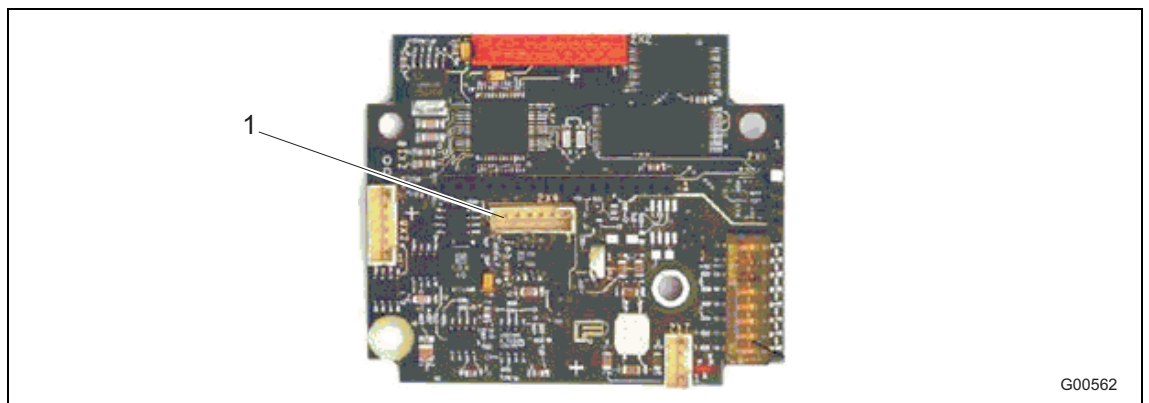

Fig. 26: Design without display

- 1 Port for the display unit

### 6.2.2.2 Configuring the design with display

A user-friendly menu with plaintext displays makes it easy to configure the transmitter. The cover must be opened to operate the device.

#### Flow range table

Nominal size	Flow range in l/min infinitely adjustable between	
	minimum (0.5 m/s)	maximum (10 m/s)
10	0.2 l/min	4 l/min
15	0.4 l/min	8 l/min
20	1.0 l/min	20 l/min
25	1.5 l/min	30 l/min
32	2.25 l/min	45 l/min
40	5 l/min	100 l/min
50	7.5 l/min	150 l/min
65	10 l/min	200 l/min
80	20 l/min	400 l/min
100	30 l/min	600 l/min

Nominal size	Flow range in USgal/min infinitely adjustable between	
	minimum (0.5 m/s)	maximum (10 m/s)
10	0.6 US gal/min	12 US gal/min
15	1.3 US gal/min	36 US gal/min
20	2.0 US gal/min	40 US gal/min
25	2.6 US gal/min	53 US gal/min
32	5.3 US gal/min	106 US gal/min
40	7.9 US gal/min	159 US gal/min
50	13.2 US gal/min	264 US gal/min
65	26.4 US gal/min	528 US gal/min
80	39.6 US gal/min	793 US gal/min
100	52.8 US gal/min	1057 US gal/min

**Display format**

The display is graphics enabled. It has a 97 x 32 pixel format.

**Process display**





The process display shows the current flow reading in the first line and the unit in the second line.

The totalizer status is displayed in the lower line in liters or US gallons. In the event of an alarm or other error, the display changes and an error message appears in plaintext.

>V	122.5
	l/min
>V	3256 l

**Data entry**

When entering data, the transmitter remains online, i.e., current and pulse outputs show the current operating mode. The functions of the individual keys are explained in the following:

	CLEAR	Toggle between operating mode and menu.
	↓	Use the arrow keys to scroll in the menu.
	↑	
	ENTER	Press both arrow keys at once to ENTER the selection. ENTER supports two functions: <ul style="list-style-type: none"> <li>• Turn on/off Programming protection.</li> <li>• Retrieve parameter to be changed and save the new value.</li> </ul>

There are two different methods of entering data:

- Numeric entry
- Entry from specified table



**Important**

When entering data, the values are checked for plausibility and, if necessary, rejected with an appropriate message.

## 6.3 Software history

Software D200B002U01		
Software Version	Type of changes	Documentation/ Enhancements
A.34	Original software	Upgrade the current transmitter software for DL43F / DL53 with model DL23.

## 7 Parameterization

### 7.1 Entering data in "short form"

Purpose	with keypad	Display information
Starting point "Process information"		-> V <b>233,55</b> l/min -> V 3,225 l
Example: End value in measurement range change Q <sub>max</sub>	#	Any parameter can appear here
Search for "Program protection" parameter	↓	"Program protection" on
"Program protection"	↵	"Program protection" off

Purpose	with keypad	Display information
Search for "Q <sub>max</sub> " parameter	Arrow keys ↓	-> V <b>233,55</b> l/min -> V 3,225 l
Alter "Q <sub>max</sub> " parameter	ENTER ↵	Q <sub>max</sub> - l/min
		Q <sub>max</sub> 6 2 0 l/min
	6 x ↑ 6	
	↓	
Input sequence of numbers wanted	2 x ↑ 2	
	↓	
Fix new "Q <sub>max</sub> " value	ENTER ↵	Q <sub>max</sub> 6 2 0 l/min

Purpose	with keypad	Display information
Search for "Current output" sub-menu	Arrow keys ↓	Sub-menu Current output
Alter "Current output" parameter	ENTER ↵	Current output 0 ... 20 mA
Alter current output from 0 ... 20 mA to 4 ... 20 mA	ENTER ↵	Current output 0 ... 20 mA
Search for current output "4 ... 20 mA" wanted in table	Arrow keys ↓	Current output 4 ... 20 mA
Fix new current output	ENTER ↵	Current output 4 ... 20 mA

Exit from Q <sub>max</sub> parameter. Search for "Program protection"	↓	"Program protection" off
Switch on "Program protection"	↵	"Program protection" on
Starting point "Process information"	#	-> V <b>233,55</b> l/min -> V 3,225 l

7.2 Data entry

Submenu/parameter	Input type	Comments
<div style="border: 1px solid black; padding: 2px;">Prog. Protection ----- Off</div> <div style="text-align: center; margin-top: 5px;">↓</div> <div style="display: flex; justify-content: space-around; align-items: center;"> <div style="border: 1px solid black; padding: 2px;">Prog. Protection ----- Off</div> <div style="border: 1px solid black; padding: 2px;">Prog. Protection ----- On</div> </div>	table format	<p><b>On / Off</b> When Prog. Protection is switched off, parameters can be changed.</p> <p>Exit the submenu via <span style="border: 1px solid black; padding: 0 5px;">#</span></p>
<div style="border: 1px solid black; padding: 2px;">Language ----- English</div> <div style="text-align: center; margin-top: 5px;">↓</div> <div style="display: flex; justify-content: space-around; align-items: center;"> <div style="border: 1px solid black; padding: 2px;">Language ----- English</div> </div>	table format	<p>German / English / French / Spanish <i>(German is the default.)</i></p> <p>Use the arrow keys to select the desired language.</p> <p>Click to confirm <span style="border: 1px solid black; padding: 0 5px;">↵</span></p>
<div style="border: 1px solid black; padding: 2px;">Nominal size ----- DN 15</div>	For information only	DN 10 to DN 100 see name plate
<div style="border: 1px solid black; padding: 2px;">QmaxDN ----- 100 l/min</div>	For information only	Highest value that can be set for the selected size Flow range end value (=10 m/s). Specified automatically based on size.
<div style="border: 1px solid black; padding: 2px;">Qmax ----- 60 l/min</div>	numerical	Flow range end value for forward and reverse flow (QmaxDN is the default). Min. flow range 0 ... 0.5 m/s, Max. flow range 0 ... 10 m/s, Selected the unit in the "Unit" submenu.
<div style="border: 1px solid black; padding: 2px;">Unit ----- l/min</div>	table format	l/s; l/min; l/h; gal/s; gal/min; gal/h (The default value is l/min)
<div style="border: 1px solid black; padding: 2px;">Damping ----- 5.0 s</div>	numerical	Configurable between 5 and 40 seconds. The damping corresponds to the response time of the 20 mA output for 0 ... 99% flowrate change ( <i>The default value is 5 s</i> ).
<div style="border: 1px solid black; padding: 2px;">Low flow cut-off ----- 1 %</div>	numerical	Range 0 ... 10% of the configured flow range. Applicable for display and all outputs. If the flowrate is below the low flow cut-off setting, the flow is not measured. Switching hysteresis for the low flow cutoff: 1 % (The default is 1% for low flow)
<div style="border: 1px solid black; padding: 2px;">Prog. input ----- Ext. cut-off</div>	table format	<p>"External output switch-off" or "External counter reset" or "No function". This menu appears only if the function is available, i.e. the option must be ordered. The 20 mA output is no longer required.</p> <p><b>Note</b> If "variant 05" appears on the name plate, this function is available. (The default for "Prog. Input" is "No function")</p>



Submenu/parameter	Input type	Comments
<div style="border: 1px solid black; padding: 5px; margin-bottom: 10px;">Prog. output Pulse</div> <div style="text-align: center;">↓</div> <div style="border: 1px solid black; padding: 5px; margin-bottom: 10px;">Pulse</div> <div style="text-align: center;">↓</div> <div style="border: 1px solid black; padding: 5px; margin-bottom: 10px;">Pulse width 600 ms</div> <div style="text-align: center;">↓</div> <div style="border: 1px solid black; padding: 5px; margin-bottom: 10px;">MAX alarm 105 %</div> <div style="text-align: center;">↓</div> <div style="border: 1px solid black; padding: 5px;">MIN alarm 0 %</div>	<p style="text-align: center;">table format</p> <div style="border: 1px solid black; padding: 5px; margin-bottom: 10px;">Prog. output Pulse</div> <div style="text-align: center;">↓</div> <div style="border: 1px solid black; padding: 5px; margin-bottom: 10px;">Prog. output Inlet/outlet signalling</div> <div style="text-align: center;">↓</div> <div style="border: 1px solid black; padding: 5px;">Prog. output General alarm</div>	<p>Configurable as pulse output or forward/reverse signaling or Min.-Alarm, Max.-Alarm, Min./Max.-Alarm, General Alarm, No Function. With pulse output, the max. pulse rate is 20 Hz. The default for "Prog. Output is always "Pulse".</p>
<div style="border: 1px solid black; padding: 5px;">Pulse 1.0 / l</div>	<p style="text-align: center;">table format</p>	<p>Configurable pulse factor (0.01 / 0.1 / 1 / 10 / 100 pulses per liter).</p>
<div style="border: 1px solid black; padding: 5px;">Pulse width 600 ms</div>	<p style="text-align: center;">For information only</p>	<p>Display only, no configuration option. The pulse width is calculated automatically based on the configured flow range end value. Pulse-pause ratio 1:1, if pulse width is within the limits of 2550 ms (max. pulse width) or 20 ms (min. pulse width). If another pulse width is desired, change the pulse factor or flow range end value (Qmax). The pulse width is calculated as follows: <math>30 / (Q_{max} \times \text{pulse factor}) = \text{pulse width in seconds}</math>, where <math>Q_{max}</math> must be set in l/min and pulse factor in pulse/liter.</p>
<div style="border: 1px solid black; padding: 5px;">MAX alarm 105 %</div>	<p style="text-align: center;">numerical</p>	<p>Configurable between 0 and 105% of configured flow range end value. The alarm message is always output in the display, it is only available as electrical signal if the following are selected in the menu: Prog. Output, Min. Alarm, Max. Alarm, Max/Min Alarm. (The default for Max. Alarm is 105%.) For pin assignments, see connection diagram.</p>
<div style="border: 1px solid black; padding: 5px;">MIN alarm 0 %</div>	<p style="text-align: center;">numerical</p>	<p>Configurable between 0 and 105% of configured flow range end value. The alarm message is always output in the display, it is only available as electrical signal if the following are selected in the menu Program Output, Min. Alarm, Max. Alarm, Min/Max Alarm. (The default for Min. Alarm is 0%.) For pin assignments, see connection diagram.</p>

Submenu/parameter	Input type	Comments
<p>The diagram shows a vertical menu structure. From top to bottom, the main menu items are: 'Current output 4-20 mA', 'Iout at alarm 21 mA', 'Reset counter', 'System zero 2.0000 Hz', and 'Flow indication Standard'. Each item has a downward arrow icon to its left. To the right of each main item is a sub-menu box. For 'Current output', the sub-menu has '4-20 mA' and '0-20 mA' options, with a downward arrow between them. For 'Reset counter', the sub-menu has 'Reset counter Yes -&gt; Enter' with a square confirmation icon to its left. For 'System zero', the sub-menu has 'manual' and 'automatic' options, with a downward arrow between them. A square confirmation icon is also present to the left of the 'Reset counter' sub-menu box.</p>	<p>table format</p> <p>table format</p> <p>table format</p>	<p>Selectable 0 ... 20 mA or 4 ... 20 mA The default for Current output is 4 ... 20 mA.</p> <p>Exit the submenu via <input type="checkbox"/> #</p> <p>or</p> <p>Click to confirm the new value <input type="checkbox"/></p> <p><b>Current output in error condition</b> With 4 ... 20 mA the following status is selectable for the current output: 0 mA; 3.6 mA; 21 mA With 0 ... 20 mA the following status is selectable for the current output: 0 mA; 21 mA The default value for I<sub>out</sub> with Alarm is 21 mA</p> <p>The totalizer in the display functions as a difference totalizer, i.e. forward and reverse totals are displayed on a meter.</p> <p>Click to reset the totalizer to zero <input type="checkbox"/></p> <p>Exit the submenu via <input type="checkbox"/> #</p> <p><b>Manual entry of zero point</b> The valve must be closed. Pipeline must be full. The fluid may not be in motion. Press ENTER to perform the automatic calibration. The limit for the zero point is 50 Hz. If the value is outside this limit, no calibration is performed.</p> <p>Exit the submenu via <input type="checkbox"/> #</p> <p><b>Normal / Inverse</b> Specify the forward flow direction for already installed device.</p>

Submenu/parameter	Input type	Comments
<div style="border: 1px solid black; padding: 2px; margin-bottom: 5px;">Display ----- Q [unit]</div> <div style="text-align: center; margin: 5px 0;">↓</div> <div style="border: 1px solid black; padding: 2px; margin-bottom: 5px;">Contrast -----</div> <div style="text-align: center; margin: 5px 0;">↓</div> <div style="border: 1px solid black; padding: 2px; margin-bottom: 5px;">Simulation ----- off</div> <div style="text-align: center; margin: 5px 0;">↓</div> <div style="border: 1px solid black; padding: 2px; margin-bottom: 5px;">DL5000      6 / 2007 ----- D699G002U01      A.34</div> <div style="border: 1px solid black; padding: 2px; margin-bottom: 5px;">Service code -----</div>	<div style="border: 1px solid black; padding: 2px; margin-bottom: 5px;"> <div style="border: 1px solid black; padding: 2px; margin-bottom: 5px;">Display ----- Q [unit]</div> <div style="text-align: center; margin: 5px 0;">↓</div> <div style="border: 1px solid black; padding: 2px; margin-bottom: 5px;">Display ----- Q [%]</div> </div> <div style="border: 1px solid black; padding: 2px; margin-bottom: 5px;"> <div style="border: 1px solid black; padding: 2px; margin-bottom: 5px;">Contrast ----- ██████████ ████████████████████</div> <div style="text-align: center; margin: 5px 0;">↓</div> </div> <div style="border: 1px solid black; padding: 2px; margin-bottom: 5px;"> <div style="border: 1px solid black; padding: 2px; margin-bottom: 5px;">Simulation ----- off</div> <div style="text-align: center; margin: 5px 0;">↓</div> <div style="border: 1px solid black; padding: 2px; margin-bottom: 5px;">Simulation ----- on</div> </div>	<p>Unit shown in the display (current flowrate and totalizer). In % or in the unit selected under the "Unit" function.</p> <p>Select ENTER to confirm or</p> <p>Exit the submenu via <span style="border: 1px solid black; padding: 2px 5px;">#</span></p> <p>Configure using the arrow keys.</p> <p><b>Flow simulation On/Off</b> E.g., to check the connected 20 mA loop or the pulse output or the forward/reverse signaling and the min. and max. alarms. Configure the flowrate using the arrow keys. Flow can be simulated in both flow directions. After switching on the simulation, enter the flowrate value in % and use ENTER to confirm. Use BACK to return to the display. "Simulation" is displayed. The unit is no longer online. The flow simulation can now be modified with the arrow keys . (More flow / Less flow). At the end of the test phase, switch off Simulation.</p> <p>Flowmeter model; date of software, part no. of software; version level</p> <p>For ABB Service only</p>

## 8 Error messages

### 8.1 Error states and alarms

State / Error	Flowrate reading / display	Notification with simulation at current output	Current output	Pulse output	Contact output
					General Alarm
1 = "AD converter/DSP"	0 %	–	Prog. Al.	0 %	Alarm
3 = "Flowrate > 105 %"	105 %	Yes	21 mA	105 %	Alarm

### 8.2 Error messages during operation and with data entry

The following tables contain error messages with additional information about the error code displayed.

Error ID and plaintext message	Priority	Description	possible reason	Error removal
Error: 1 AD converter	1	The AD converter is saturated and is not responding.	The input measuring signal is too large.	Check ground (flowmeter). Check the measuring range setting, the measuring range selected may be too small.
			The AD converter is defective.	Replace transmitter plug-in module.
Error: 3 Flowrate > 105 %	2	The maximum configured measuring range is exceeded by more than 5 %.	The flow is too large or the configured measuring range is too small.	Increase the measuring range or reduce flowrate.

## 9 Maintenance / Repair

Repair and maintenance activities may only be performed by authorized customer service personnel.

When replacing or repairing individual components, original spare parts must be used.



### **Warning - Potential damage to parts!**

The electronic components of the printed circuit board can be damaged by static electricity (observe ESD guidelines).

Make sure that the static electricity in your body is discharged before touching electronic components.

When the housing is open, EMC protection is limited.

### 9.1 Maintenance for the flowmeter

Essentially no maintenance is required for the flowmeter primary. The following items should be checked annually:

- Ambient conditions (air circulation, humidity)
- Seal integrity of the process connections
- Cable entry points and cover screws
- Operational reliability of the supply power feed, the lightning protection and the grounds

The flowmeter primary electrodes must be cleaned when the flowrate information on the transmitter changes when recording the identical flowrate volume. If the display shows a higher flowrate, the contamination is insulating. If the flowrate displayed is lower, the contamination results in a short-circuit.

For repairs to the lining, electrodes or magnet coil, the flowmeter must be returned to the head office in Göttingen.



### **Important**

When sending the flowmeter to the head office of ABB Automation Products GmbH, complete the return form in the appendix and include with device.

### 9.2 Cleaning

When cleaning the exterior of meters, make sure that the cleaning agent used does not corrode the housing surface and the seals.

### 9.3 Gaskets

Some device designs are shipped with special gaskets. These gaskets must be used and installed properly to prevent leakage.

For all other device designs, use commercially available gaskets made from material which is compatible with the fluid and prevailing temperature (PTFE, EPDM, silicon, Viton, etc.) and which conforms to FDA standards, if necessary.



#### Important

A flowmeter primary in wafer configurations is installed without gaskets directly in the pipeline.

### 9.4 Replacing the transmitter



#### Warning - Potential damage to parts!

The electronic components of the printed circuit board can be damaged by static electricity (observe ESD guidelines).

Make sure that the static electricity in your body is discharged before touching electronic components.

When the housing is open, EMC protection is limited.

The transmitter plug-in module can be replaced without loss of function for all sizes from DN 10 to DN 100.

When ordering replacement flowmeters, the order number must be provided so that the factory can program the calibration values and size for the associated flowmeter primary.

## 10 Spare parts list

### 10.1 Fuses on the transmitter electronic unit



**Warning - Potential damage to parts!**

The electronic components of the printed circuit board can be damaged by static electricity (observe ESD guidelines).

Make sure that the static electricity in your body is discharged before touching electronic components.

When the housing is open, EMC protection is limited.

**Replacing the fuse**

- Unscrew the cover and display unit (if present).

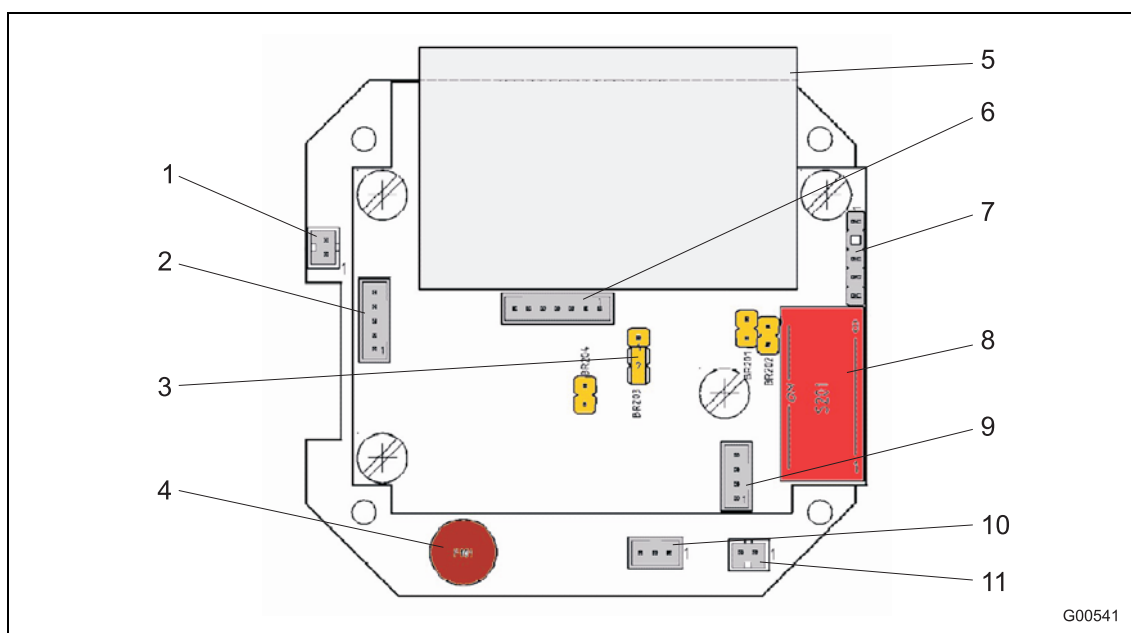

Fig. 27: Transmitter electronics

- |  |  |
|--|--|
| <ul style="list-style-type: none"> <li>1 Connection for excitation cable</li> <li>2 Electrode signal</li> <li>3 Jumper BR203: The jumper must be in this position for operation. All other jumpers must be open. They are intended for internal purposes.</li> <li>4 Fuse for supply power 500 mA T</li> <li>5 20 mA module plug-in</li> </ul> | <ul style="list-style-type: none"> <li>6 Connection for the display</li> <li>7 TTL connection</li> <li>8 DIP switch for measuring range 20 mA, damping, etc. (for model DL53 only)</li> <li>9 Connection for cable set 20 mA / signal / contact input</li> <li>10 Connection for "Supply power" cable set</li> <li>11 Connection for "Pulse output" cable set</li> </ul> |
|--|--|

	Parameter	Order number
4	Fuse for supply power on electronic plug-in unit 500 mA T	D151F003U15

## 10.2 Contact information at ABB Service for spare parts

Spare parts can be ordered from ABB Service:

### E-Mail

parts-repair-goettingen@de.abb.com

### Telephone

+49 180 5222 580

## 10.3 Spare parts for the transmitter

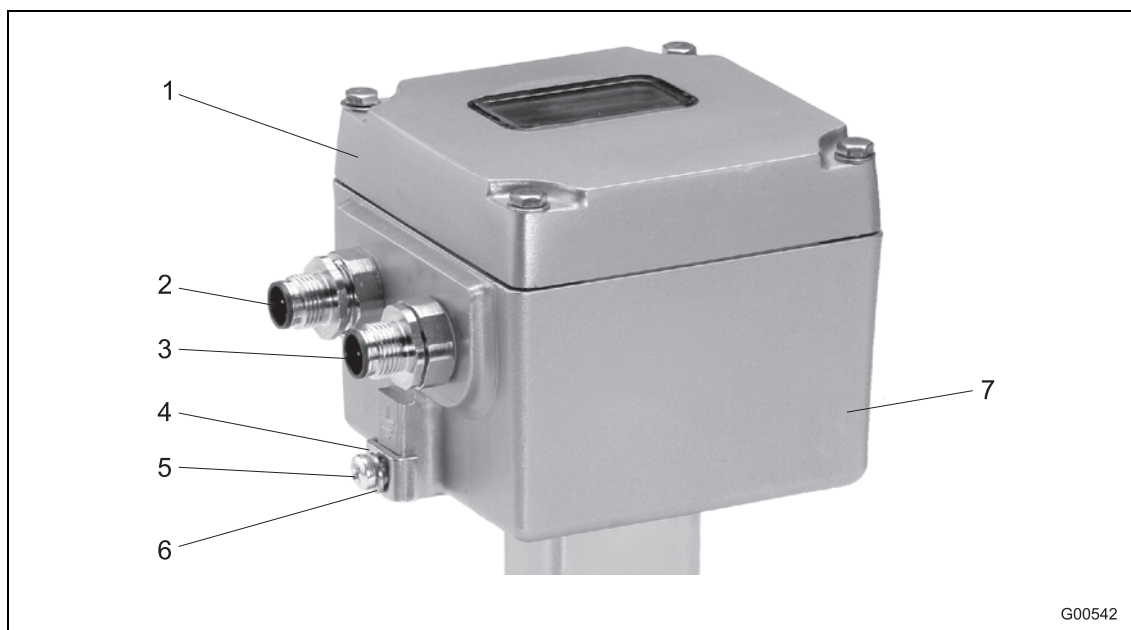

Fig. 28: Transmitter housing

No.	Parameter	Order number
1	Cover with washer and gasket, assembly W. 1.4308	D613A038U02
2	Plug with M12 x 1 cable set, supply power	D677A415U01
3	Plug with M12 x 1 cable set, current / pulse / contact output	D677A415U02
	Plug with M12 x 1 cable set, contact input / pulse / contact output	D677A415U03
4	Clamp strap DIN 46282 #6504 E MS	D108A003U01
5	Phillips screw M5.0X 8 DIN 84 SS	D002H107AU2
6	Spring washer B 5.0 DIN 127 SS	D085C023BU2
7	Connection box precision casting W. 1.4308	D323C558U03



## 11 Technical data

### 11.1 Measuring accuracy

#### 11.1.1 Reference conditions per EN 29104

Fluid temperatures	20 °C (68 °F) ± 2 K (3.6 °F)
Ambient temp.	20 °C (68 °F) ± 2 K (3.6 °F)
Auxiliary power	Line voltage per name plate $U_N \pm 1\%$ and Frequency $f \pm 1\%$
Installation Conditions	<ul style="list-style-type: none"> <li>upstream &gt; 10 x DN straight section</li> <li>downstream &gt; 5 x DN straight section</li> </ul>
Warm Up Phase	30 min

#### 11.1.2 Maximum Measurement Error

Pulse output (standard calibration):

- $Q > 0.07 Q_{\max DN} \pm 0.5\%$  of rate
- $Q < 0.07 Q_{\max DN} \pm 0.00035 Q_{\max DN}$

$Q_{\max DN}$  = maximum flowrate for the flowmeter size 10 m/s

#### Analog Output Effects

Same as pulse output plus  $\pm 0.1\%$  of rate  $\pm 0.1\%$  of full scale.

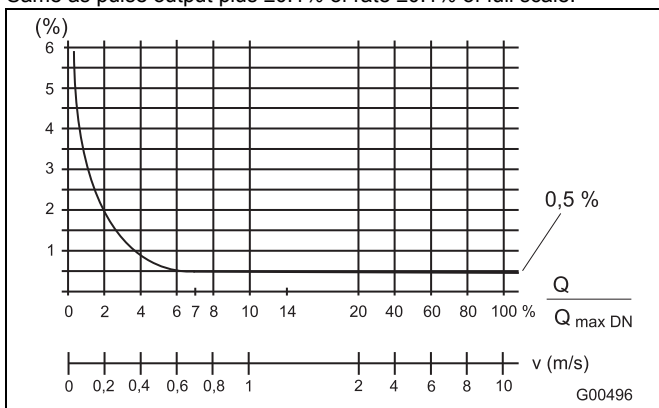

Fig. 29

### 11.2 Flowmeter sensor

#### 11.2.1 General specifications

##### Minimum Allowable Absolute Pressure

Liner	Meter size DN (3/8 ... 4")	$P_{\text{Operating}}$ mbar abs	at	$T_{\text{Operating}}$ *
PFA	10 ... 100	0		130 °C (266 °F)

\* Higher temperatures are allowed for CIP/SIP cleaning for limited time periods, see Table "Maximum Allowable Cleaning Temperature".

##### Max. Allowable Cleaning Temperature

CIP-Cleaning	Flowmeter primary liner:	$T_{\max}$	$t_{\max}$	$T_{\text{amb.}}$
Steam cleaning	PFA	150 °C (302 °F)	60 min	25 °C (77 °F)
Liquid cleaning	PFA	140 °C (284 °F)	60 min	25 °C (77 °F)

If the ambient temperature is  $> 25\text{ °C}$  ( $> 77\text{ °F}$ ), then the difference must be subtracted from the max. cleaning temperature.

$$T_{\text{Cleaning}} = T_{\max} - \Delta\text{ °C (°F)}$$

$$\Delta\text{ °C} = T_{\text{amb}} - 25\text{ °C (77 °F)}$$

##### Maximum Allowable Temperature Shock

Liner	Temp Shock max. Temp. Diff. °C (°F)	Temp. gradient °C/min
PFA	any	any

##### Max. Allowable Fluid Temperature as a Function of Ambient Temperature

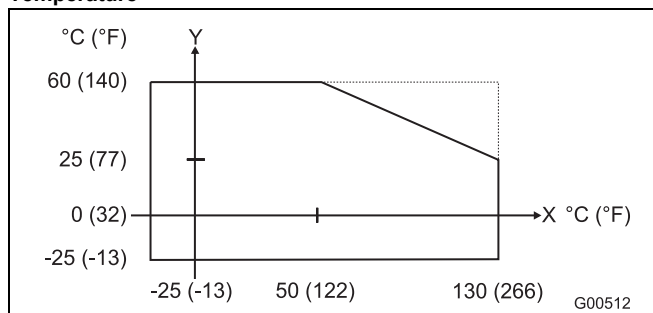

Fig. 30

x = Fluid temperature °C (°F)  
y = Ambient temperature °C (°F)

##### Ambient conditions

Ambient temp. -25 ... 60 °C (-13 ... 140 °F)  
Fluid Temperatures -25 ... 130 °C (-13 ... 266 °F)  
Storage Temperature -25 ... 70 °C (-13 ... 158 °F)

## Technical data

### Materials, Flowmeter Primary

Liner	Electrode material		Electrodes Design	
	Standard	Options	Standard	Options
PFA	1.4539	Hast.-C4, Hast.-B3 SS 1.4539 SS 1.4571 Titanium, Tantalum, Platinum- Iridium	Flat head	Pointed head

### Process Connection Materials

	Standard
Wafer design	None
Weld stubs	SS 1.4404 [304]
Threaded pipe connection	SS 1.4404 [304]
Tri-Clamp	SS 1.4404 [304]
External threads	SS 1.4404 [304]

### Materials in other components

Component	Standard	Option
Connection box	SS 1.4308	-
Meter tube	SS 1.4301	-
Connector	Housing: Brass (nickel-plated) O-Ring Gasket: FKM Contacts: Copper (gold-plated)	-
Flowmeter primary housing	Deep-drawn housing SS 1.4301 [304]	

### Gasket Material

Process Connection	Gasket Material
Wafer design	None
Weld stubs, threaded connection, Tri-Clamp, external threads	EPDM (Ethylene-Propylene) with FDA approval, silicone with FDA approval (option)
Flat gaskets	Silicone

### Protection Class per EN 60529

IP 67

### Pipeline Vibration Following EN 60068-2-6

In the range of 10 ... 55 Hz, with max. 0.15 mm deflection

In the range of 55 ... 150 Hz, with max. 2 g acceleration

## 11.2.2 Material load for variable process connections

Process connection	Meter size DN	PS <sub>max</sub> (bar)	TS <sub>min</sub>	TS <sub>max</sub>
Wafer design	10 ... 50 (3/8 ... 2")	40 (CL 300)	-25 °C (-13 °F)	130 °C (266 °F)
	65 ... 100 (2 1/2 ... 4")	16 (CL 150)		
	10 ... 40 (3/8 ... 1 1/2")	40		
Weld stubs	50, 80 (2", 3")	16	-25 °C (-13 °F)	130 °C (266 °F)
	65, 100 (2 1/2, 4")	10		
	10 ... 40 (3/8 ... 1 1/2")	40		
Threaded connection per DN 11851	50, 80 (2", 3")	16	-25 °C (-13 °F)	130 °C (266 °F)
	65, 100 (2 1/2, 4")	10		
	10 ... 50 (3/8 ... 2")	16		
Tri-Clamp per DIN 32676	65 ... 100 (2 1/2 ... 4")	10	-25 °C (-13 °F)	121 °C (250 °F)
	10 ... 100 (3/8 ... 4")	10		
	10 ... 25 (3/8 ... 1")	16		
Tri-Clamp per ASME BPE	10 ... 100 (3/8 ... 4")	10	-25 °C (-13 °F)	130 °C (266 °F)
	10 ... 25 (3/8 ... 1")	16		
External threads ISO 228	10 ... 25 (3/8 ... 1")	16	-25 °C (-13 °F)	130 °C (266 °F)

## 11.2.3 Material load for wafer configuration

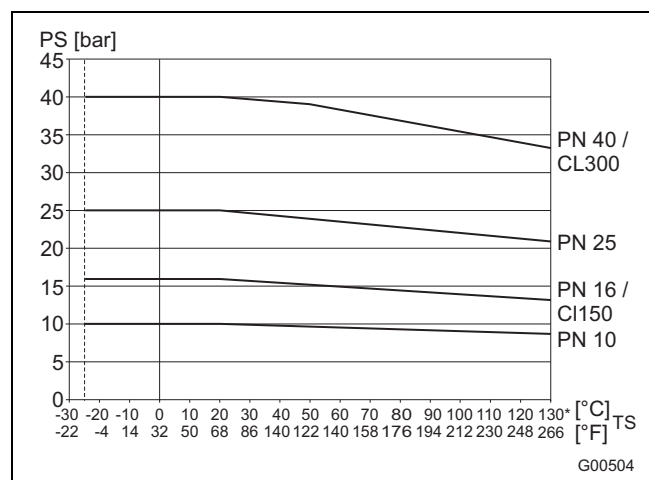

Fig. 31

\*) Higher temperatures are allowed for CIP/SIP cleaning for limited time periods, see Table "Maximum Allowable Cleaning Temperature".

### JIS 10K-B2210 Wafer Design

Meter size DN	Material	PN	TS	PS (bar)
32-100 (1 1/4 ... 4")	SS 1.4404 SS 1.4435 SS 1.4301	10	-25 ... 130 °C (-13 to 266 °F)	10

## 11.3 Transmitter

### 11.3.1 General specifications

<b>Flow range</b>	Continuously adjustable 0.5 ... 10 m/s
<b>Max. accuracy</b>	≤ 0.5 % of rate
<b>Reproducibility</b>	≤ 0.15% of measured value
<b>Minimum conductivity</b>	20 μS/cm
<b>Response time</b>	As step function 0 ... 99% (corr. to $5 \tau$ ) ≥ 5 s
<b>Supply power</b>	Low voltage AC: 16.8 ... 26.4 V Low voltage DC: 16.8 ... 31.2 V Ripple: < 5 %
<b>Magnetic field supply</b>	6¼ Hz
<b>Power</b>	≤ 6 VA / 5 W for AC/DC supply power (flowmeter primary incl. transmitter)
<b>Ambient temp.</b>	-25 ... 60 °C (-13 ... 140 °F)
<b>Electrical connection</b>	M12-Lumberg connectors for supply power and signal inputs/outputs
<b>Forward / Reverse Flow Metering</b>	Flow direction is indicated by direction arrows in the display and signaled over the optocoupler output (ext. signaling).
<b>Current output (only variants 02, 04)</b>	0/4 ... 20 mA Load < 600 Ω
<b>Pulse output, passive</b>  <b>or</b>  <b>Contact output, passive</b>  <b>selectable</b>	$16 \text{ V} \leq U_{CEH} \leq 30 \text{ V};$ $0 \text{ V} \leq U_{CEL} \leq 2 \text{ V};$ $0 \text{ mA} \leq I_{CEH} \leq 0.2 \text{ mA};$ $2 \text{ mA} \leq I_{CEL} \leq 220 \text{ mA}$  <b>Pulse output function:</b> $F_{\max} = 20 \text{ pulses/s};$ Pulse width min. 20 ms; max. 2550 ms  <b>Contact output function:</b> Forward / reverse signaling, Max-Min alarm, system alarm
<b>Contact input (only variant 5)</b>	On: $16 \text{ V} \leq U_{CEH} \leq 30 \text{ V DC}$ Off: $0 \text{ V} \leq U_{CEL} \leq 2 \text{ V DC}$ $R_i = 2 \text{ K}\Omega$  <b>Function:</b> Totalizer reset or ext. zero return.

## 12 Appendix

## 12.1 Permits and certifications

	Symbol	Description
CE mark		<p>The CE mark indicates that the device complies with the following directives and their basic safety requirements:</p> <ul style="list-style-type: none"> <li>• CE mark on the name plate of transmitter <ul style="list-style-type: none"> <li>– Conforms with EMC directive 89/336/EEC</li> </ul> </li> <li>• CE mark on the builder's plate of flowmeter primary <ul style="list-style-type: none"> <li>– Conforms with pressure equipment directive (PED) 97/23/EC</li> </ul> </li> </ul> <p>By placing the CE mark on its devices, ABB Automation Products GmbH declares its conformance with these directives.</p> <p>Pressure equipment does <b>not</b> receive a CE mark on the builder's plate, if the following conditions exist:</p> <ul style="list-style-type: none"> <li>• The max. permissible pressure (PS) is less than 0.5 bar.</li> <li>• Due to minimal safety risks (meter size <math>\leq</math> DN 25 / 1") no approval procedures are required.</li> </ul> <p>This unit was designed and manufactured in accordance with "sound engineering practices".</p>



**EG-Konformitätserklärung  
EC-Certificate of Compliance**



Hiermit bestätigen wir die Übereinstimmung der aufgeführten Geräte mit den Richtlinien des Rates der Europäischen Gemeinschaft. Die Sicherheits- und Installationshinweise der Produktdokumentation sind zu beachten.

*Herewith we confirm that the listed instruments are in compliance with the council directives of the European Community. The safety and installation requirements of the product documentation must be observed.*

Modell: EcoMaster Hygienic FXL4000-DL23  
Model:

Richtlinie: EMV Richtlinie 89/336/EWG \*  
Directive: EMC directive 89/336/EEC \*

Europäische Norm: EN 61326, 5/2004 \*  
European Standard:

\* einschließlich Nachträge  
including alterations

Göttingen, 18.06.2007

ppa.   
B. Kammann, APR-I Göttingen

BZ-13-5035, Rev.02, 10052

**ABB Automation Products GmbH**

Postanschrift:  
Dransfelder Str. 2  
D-37079 Göttingen

Besuchsanschrift:  
Dransfelder Str. 2  
D-37079 Göttingen  
Telefon +49 551 905 0  
Telefax+49 551 905 777  
Internet: <http://www.abb.com/de>

Sitz der Gesellschaft:  
Ladenburg  
Registergericht:  
Amtsgericht Mannheim  
Handelsregister:  
HRB 700229  
USt-IdNr.: DE 115 300 097

Vorsitz des Aufsichtsrates:  
Heinz-Peter Paffenholz  
Geschäftsführung:  
Christian Wendler

Bankverbindung:  
Commerzbank AG Frankfurt  
Konto: 589 635 200  
BLZ: 500 400 00



## EG-Konformitätserklärung EC-Declaration of Conformity



Hiermit bestätigen wir die Übereinstimmung des aufgeführten Gerätes mit den Richtlinien des Rates der Europäischen Gemeinschaft, welche mit dem CE-Zeichen gekennzeichnet sind. Die Sicherheits- und Installationshinweise der Produktdokumentation sind zu beachten.

*Herewith we confirm that the listed instrument is in compliance with the council directives of the European Community and are marked with the CE marking. The safety and installation requirements of the product documentation must be observed.*

Hersteller: <i>manufacturer:</i>	ABB Automation Products GmbH, 37070 Göttingen - Germany
Modell: <i>model:</i>	D_2..., D_2_W, D_4_W, SE2..., SE2_W D_2..., D_2_W, D_4_W, SE2..., SE2_W
Richtlinie: <i>directive:</i>	Druckgeräterichtlinie 97/23/EG <i>pressure equipment directive 97/23/EC</i>
Einstufung: <i>classification:</i>	Ausrüstungsteile von Rohrleitungen <i>pipng accessories</i>
Normengrundlage: <i>technical standard:</i>	AD 2000 Merkblätter
Konformitätsbewertungsverfahren: <i>conformity assessment procedure:</i>	B1 (EG-Entwurfsprüfung) + D (Qualitätssicherung Produktion) <i>B1 (EC design-examination) + D (production quality assurance)</i>
EG-Entwurfsprüfbescheinigung: <i>EC design-examination certificate:</i>	Nr. 07 202 0124 Z 052/2/0006
benannte Stelle: <i>notified body:</i>	TÜV Nord e.V. Rudolf-Diesel-Str. 5 37075 Göttingen - Germany
Kennnummer: <i>identification no.</i>	0045

Göttingen, den 21.05.2002

ppa .....  
(K.Wiskow, Personalleiter APR Göttingen)

**12.2 Additional documents**

- Data sheet (D184S076Uxx)
- Brochure (PB/ECOMASTER\_HY\_xx)

## 12.3 Overview of technical design and setting parameters

Measuring point:		TAG no.:	
Device type: EcoMaster Hygienic FXL4000-DL23			
Order no.:	Device no.:	Order no.:	
Measured medium temp.:		Power supply:	
Lining:	Electrodes:	System zero point:	
C <sub>zero</sub> :	C <sub>Span</sub> :		

Parameters		Setting range
Language:	.....	e.g., German, English, French, etc.
Nominal size:	.....	DN 10 ... DN 100
Q <sub>max</sub> :	.....	0.05 Q <sub>max</sub> DN -1 Q <sub>max</sub> DN
Pulse factor:	.....	Pulse / phys. unit
Pulse width:	.....	0, 100 ... 2000 ms
Low cut-off setting:	.....	0 ... 10% of flow range end value
Damping:	.....	5 ... 40 s
Unit Q <sub>max</sub> :	.....	e.g., l/s, l/min, l/h, etc.
Unit totalizer:	.....	e.g., l, m <sup>3</sup> , US gal, etc.
Max. alarm:	.....	%
Min. alarm:	.....	%
Contact output:	.....	Max. alarm, Min. alarm, Max./Min. alarm, general alarm, pulses, no function
Contact input:	.....	External cutoff, totalizer reset, no function
Current output:	.....	0/4 ... 20 mA
I <sub>out</sub> with alarm:	.....	0, 3.6 mA to 21 mA
1. Display line:	.....	Q (%), Q (unit)
2. Display line:	.....	Totalizer V/R
Directional display:	.....	Normal, inverse



**Statement about the contamination of devices and components**

The repair and/or maintenance of devices and components will only be performed when a completely filled out explanation is present.

Otherwise, the shipment can be rejected. This explanation may only be filled out and signed by authorized specialist personnel of the operator.

**Customer details:**

Company: \_\_\_\_\_

Address: \_\_\_\_\_

Contact person: \_\_\_\_\_

Telephone: \_\_\_\_\_

Fax: \_\_\_\_\_

E-Mail: \_\_\_\_\_

**Device details:**

Type: \_\_\_\_\_

Serial no.: \_\_\_\_\_

Reason for the return/description of the defect: \_\_\_\_\_  
 \_\_\_\_\_  
 \_\_\_\_\_**Was this device used for working with substances which pose a threat or health risk?** Yes       No

If yes, which type of contamination (please place an X next to the applicable items)

biological	<input type="checkbox"/>	corrosive/irritating	<input type="checkbox"/>	combustible (highly/extremely combustible)	<input type="checkbox"/>
toxic	<input type="checkbox"/>	explosive	<input type="checkbox"/>	other harmful substances	<input type="checkbox"/>
radioactive	<input type="checkbox"/>				

Which substances have had contact with the device?

1. \_\_\_\_\_

2. \_\_\_\_\_

3. \_\_\_\_\_

We hereby certify that the devices/parts shipped were cleaned and are free from any dangerous or poisonous materials.

\_\_\_\_\_  
City, Date\_\_\_\_\_  
Signature and company stamp

**13 Index**

<b>A</b>	
Additional documents .....	47
Allowed Fluids.....	8
Appendix .....	44
<b>C</b>	
Cleaning.....	38
Commissioning the unit .....	27
Configuring the design with display .....	28
Configuring the device design without display.....	27
Connection Examples for Peripherals .....	23
Contact at ABB Service .....	40
<b>D</b>	
Data entry .....	32
Design.....	16
Design and function .....	15
Device configuration .....	27
Device design .....	16
Disposal .....	13
<b>E</b>	
Electrical connection.....	22
Electrical installation safety information.....	14
Electrode axis .....	17
Entering data in.....	31
Error messages.....	36
Error messages during operation and with data entry .....	36
Error states and alarms .....	36
<b>F</b>	
Factory Tag.....	9
Factory Tag.....	11
Flowmeter primary with variable process connection .....	26
Flowmeter primary with wafer connection .....	24
Flowmeter sensor .....	41
Free inlet or outlet.....	18
Fuses for transmitter electronics.....	39
<b>G</b>	
Gaskets.....	38
General information on ground connections.....	24
General information on installation .....	17
General information on transport.....	16
General Safety Information.....	6
General specifications.....	41, 43
Ground .....	24
Ground with conductive PTFE grounding plate .....	26
<b>H</b>	
Horizontal connections .....	17
<b>I</b>	
Improper use.....	7
In- and outlet pipe sections.....	17
Inspection.....	16, 26
Installation.....	17
Installation of pumps .....	18
Installation Requirements .....	17
Installation safety information .....	13
Intended use .....	6
<b>L</b>	
Labels and symbols .....	8
<b>M</b>	
Maintenance / Repair.....	37
Maintenance for the flowmeter .....	37
Material load for variable process connections .....	42
Material load for wafer configuration.....	42
Maximum Measurement Error .....	41
Measuring accuracy.....	41
Measuring principle.....	15
Metal pipe with fixed flanges.....	24
Metal pipe with loose flanges.....	25
Mounting the meter tube .....	19
<b>N</b>	
Name plate.....	9, 10
Name Plate .....	9
Non-metallic pipes .....	25
<b>O</b>	
Operating safety information.....	14
Operator liability .....	12

Overview of technical design and setting parameters .....	48	Strongly contaminated fluids.....	18
<b>P</b>		Switching on supply power .....	27
Parameter description.....	32	<b>T</b>	
Parameterization.....	31	Technical data.....	41
Permits and certifications.....	44	Technical limit values.....	7
Personnel qualification.....	12	Torque information.....	20
Pipes with insulating liner .....	25	Transmitter.....	43
<b>R</b>		Transport.....	16
Reducers.....	18	Transport safety information .....	13
Reference conditions per EN 29104.....	41	<b>V</b>	
Replacing the transmitter .....	38	Variable process connections for model DL23 .....	20
Returning devices .....	12	Variant 1 (without display) or variant 3 (with display) .....	23
Rotating the display .....	21	Variant 2 (without display) or variant 4 (with display) .....	23
<b>S</b>		Variant 5 (with display) .....	23
Safety.....	6	Vertical connections.....	17
Safety information for maintenance and inspection.	14	<b>W</b>	
Software history .....	30	Wafer unit model DL23W.....	20
Spare parts for the transmitter.....	40	Warranty provision .....	8
Spare parts list.....	39	WEEE directive .....	13
Startup Operation.....	26		

---

ABB has Sales & Customer Support  
expertise in over 100 countries worldwide.

[www.abb.com/flow](http://www.abb.com/flow)

The Company's policy is one of continuous product  
improvement and the right is reserved to modify the  
information contained herein without notice.

Printed in the Fed. Rep. of Germany (06.2008)

© ABB 2008



**ABB Limited**

Oldends Lane, Stonehouse  
Gloucestershire, GL10 3TA  
UK

Tel: +44 (0)1453 826661  
Fax: +44 (0)1453 829671

**ABB Inc.**

125 E. County Line Road  
Warminster, PA 18974  
USA

Tel: +1 215 674 6000  
Fax: +1 215 674 7183

**ABB Automation Products GmbH**

Dransfelder Str. 2  
37079 Goettingen  
Germany

Tel: +49 551 905-534  
Fax: +49 551 905-555  
CCC-support.deapr@de.abb.com