

Operating instructions

600T Series

Model 653S
Electronic configurable
temperature transmitter

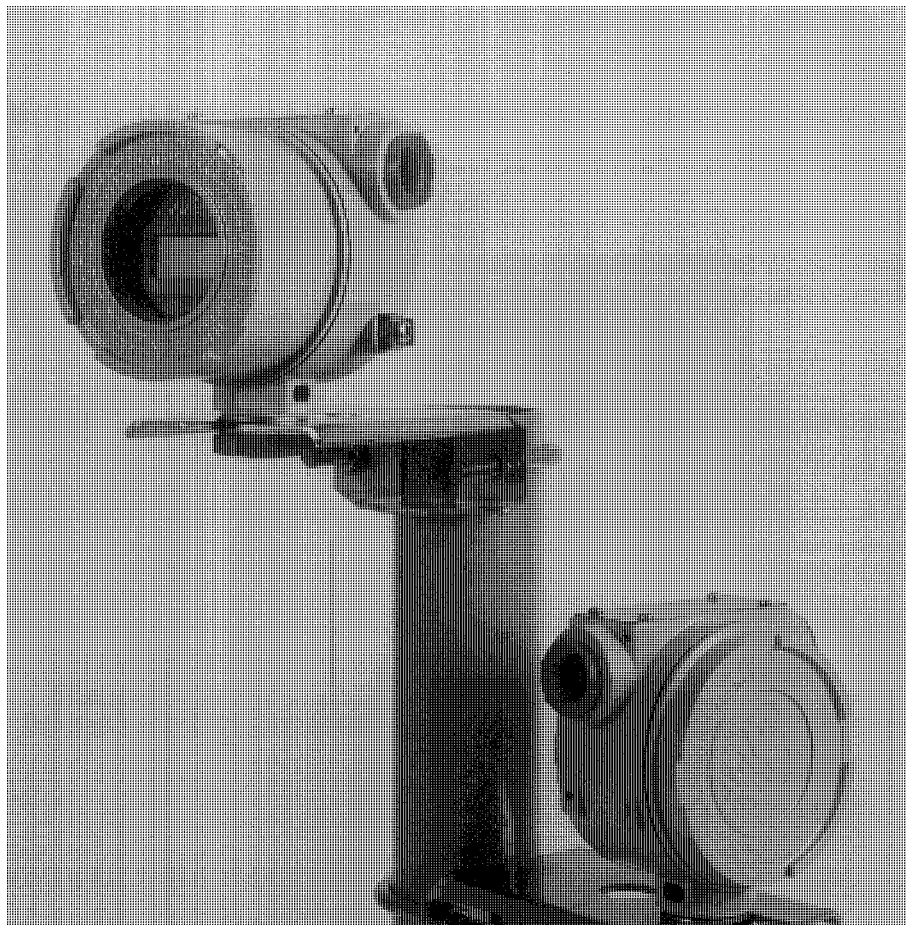

ABB

ABB INSTRUMENTATION

The Company

ABB Instrumentation is an established world force in the design and manufacture of instrumentation for industrial process control, flow measurement, gas and liquid analysis and environmental applications.

As a part of ABB, a world leader in process automation technology, we offer customers application expertise, service and support worldwide.

We are committed to teamwork, high quality manufacturing, advanced technology and unrivalled service and support.

The quality, accuracy and performance of the Company's products result from over 100 years experience, combined with a continuous program of innovative design and development to incorporate the latest technology.

The NAMAS Calibration Laboratory No. 0255(B) is just one of the ten flow calibration plants operated by the Company, and is indicative of ABB Instrumentation's dedication to quality and accuracy.

BS EN ISO 9001



St Neots, U.K. – Cert. No. Q5907
Stonehouse, U.K. – Cert. No. FM 21106

UNI EN 29001 (ISO 9001)



Lenno, Italy – Cert. No. 9/90A



Stonehouse, U.K. – Cert. No. 0255

Use of Instructions



Warning.

An instruction that draws attention to the risk of injury or death.



Note.

Clarification of an instruction or additional information.



Caution.

An instruction that draws attention to the risk of damage to the product, process or surroundings.



Information.

Further reference for more detailed information or technical details.

Although **Warning** hazards are related to personal injury, and **Caution** hazards are associated with equipment or property damage, it must be understood that operation of damaged equipment could, under certain operational conditions, result in degraded process system performance leading to personal injury or death. Therefore, comply fully with all **Warning** and **Caution** notices.

Information in this manual is intended only to assist our customers in the efficient operation of our equipment. Use of this manual for any other purpose is specifically prohibited and its contents are not to be reproduced in full or part without prior approval of Technical Communications Department, ABB Instrumentation.

Health and Safety

To ensure that our products are safe and without risk to health, the following points must be noted:

1. The relevant sections of these instructions must be read carefully before proceeding.
2. Warning labels on containers and packages must be observed.
3. Installation, operation, maintenance and servicing must only be carried out by suitably trained personnel and in accordance with the information given.
4. Normal safety precautions must be taken to avoid the possibility of an accident occurring when operating in conditions of high pressure and/or temperature.
5. Chemicals must be stored away from heat, protected from temperature extremes and powders kept dry. Normal safe handling procedures must be used.
6. When disposing of chemicals ensure that no two chemicals are mixed.

Safety advice concerning the use of the equipment described in this manual or any relevant hazard data sheets (where applicable) may be obtained from the Company address on the back cover, together with servicing and spares information.

CONTENTS

SECTION	PAGE
1 GENERAL DESCRIPTION	1
2 TRANSPORT, HANDLING AND PRODUCT IDENTIFICATION	2
3 PRINCIPLE OF OPERATION	3
4 INSTALLATION	4-5
5 ELECTRICAL CONNECTIONS	6
6 ELECTRICAL REQUIREMENTS	7
7 CONFIGURATION AND CALIBRATION	7
8 ASSEMBLING OF A TEMPERATURE SENSOR TO THE HOUSING	8
9 ADDENDUM FOR METER OPTION	9-10
10 RETURNING FORM	11

1 GENERAL DESCRIPTION

Model 653S is a field mounted temperature Smart transmitter with microprocessor based electronics.

The output signal is 4-20 mA with superimposed digital process variable for HART® communication.

It is designed to measure signals from thermocouples, resistance thermometers, or e.m.f. (mV) sources.

The temperature transmitter is available either as a compact version without temperature sensor and with standard configuration, or in a version with integrally mounted temperature sensor and specific configuration and calibration.

The electronics use non-volatile memory; additional security is given by up/down scale procedure under sensor anomalies.

This Smart transmitter provides the added capability of bidirectional digital communication with the Hand Held Communicator model KHT or with any remote transmitter interface supporting the HART® Protocol.

The communication protocol allows remote re-ranging, calibration and diagnostics without interfering with the normal 4 to 20 mA signal.

2 TRANSPORT

After final calibration, the instrument is packed in a carton (*) intended to provide protection from physical damage.

(*) Type 2 to ANSI/ASME N45.2.2-1978

2 STORAGE

The instrument does not require any special treatment if stored as despatched and within the specified ambient conditions level. There is no limit to the storage period, although the terms of guarantee remain as agreed with the Company and as given in the order acknowledgement.

2 HANDLING

The instrument does not require any special precautions during handling although normal good practice should be observed.

2 PRODUCT IDENTIFICATION

The instrument is identified by the data plates shown in the figure 1.

The Nameplate (ref. A) provides information concerning the code number, input source, power supply and output signal.

The Serial Number plate (ref. B) shows the transmitter serial number. Please refer to this number when making enquiries.

Two other plates are optionally supplied:

A wired-on type, providing the customer tag number and calibrated range.

A Safety Marking plate (ref. C) fitted when the transmitter is required to comply with hazardous area regulations e.g. flameproof or intrinsic safety protection.

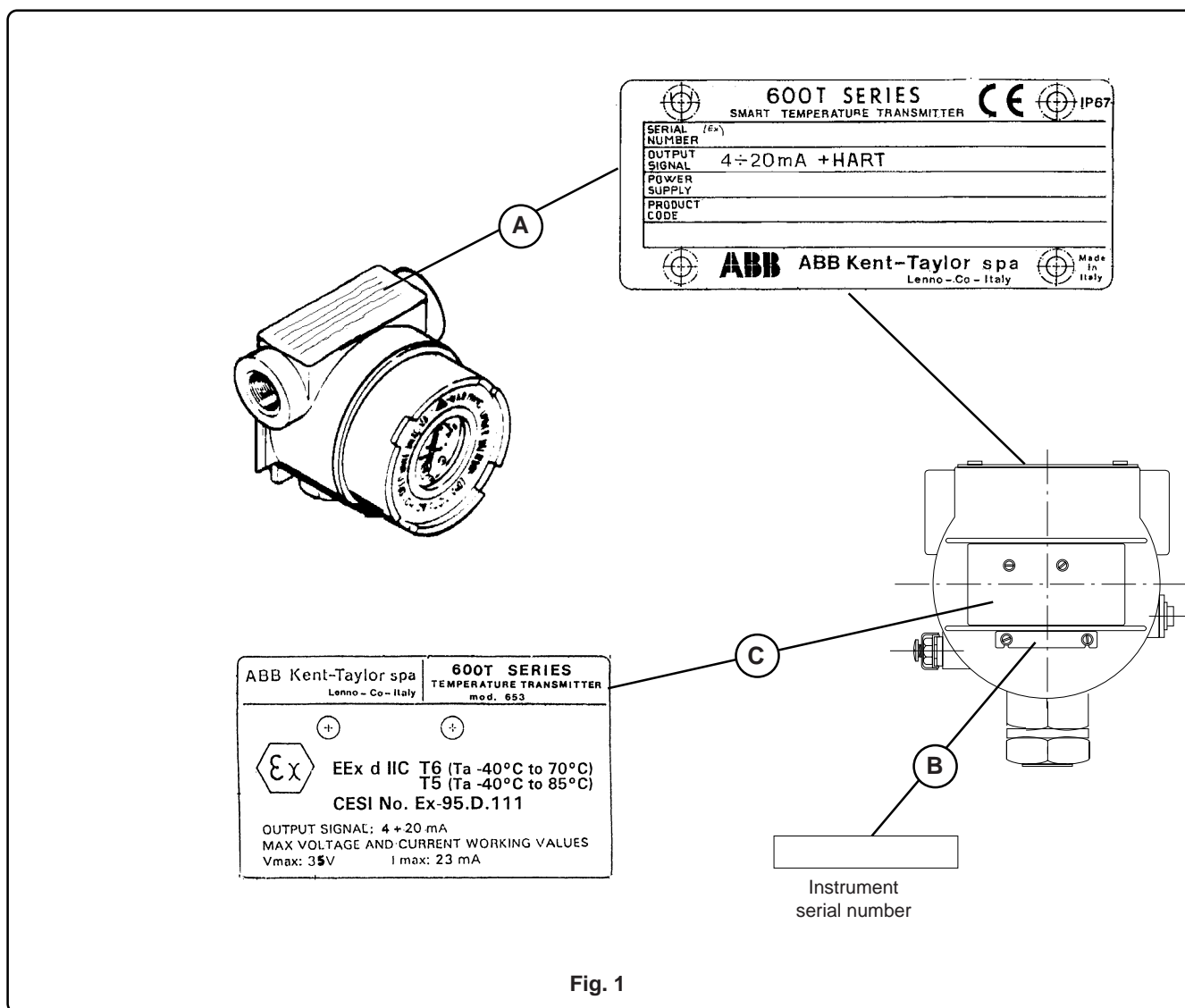

Important

The instrument serial number must always be quoted when making enquiries.

3 PRINCIPLE OF OPERATION

The instrument consists of housing containing the electronic unit including the terminal block for connecting the input signal (from thermocouple, thermoresistance, etc), the supply/output (4-20 mA) and the output meter (optional). The transmitter may be supplied with or without integral sensor, appropriately fitted to the housing.

The signal from the sensor is connected to the input circuit which automatically provides appropriate amplification for the type of sensor selected, burn out protection (up scale/down scale according to the selection) and cold junction compensation (for the THC).

Galvanic separation is provided between the input circuitry and the output to guarantee proper immunity from ground loops. The main electronic circuit includes the microprocessor with its auxiliary timing/clock circuits and PROM, the characterization EEPROM, the D/A converter and the output stage 4 ÷ 20 mA.

Modifiable data like the calibration and, generally speaking, all the data that can be changed by the user through the configurator devices are stored in a non volatile memory.

These parameters are processed by the microprocessor using a suitable algorithm to provide an accurate input/output relationship with temperature compensation.

A microprocessor provides bidirectional digital communication with the configuration device, i.e. the Hand Held Terminal "Communicator" or P.C. "Configurator", using the Hart® Protocol.

This protocol is based on the standard Bell 202 FSK (Frequency Shift Keying) with a ± 0.5 mA signal modulation superimposed on the 4 to 20 mA analog signal: as the energy balance added to the current loop is virtually zero and the frequency is very high compared to that of the process dynamic, the analog process signal remains undisturbed.

Using the configuration devices it is possible to remotely modify the configuration of the transmitter including the measuring range (see below for connection). It is also possible to read other transmitter data and diagnostic information.

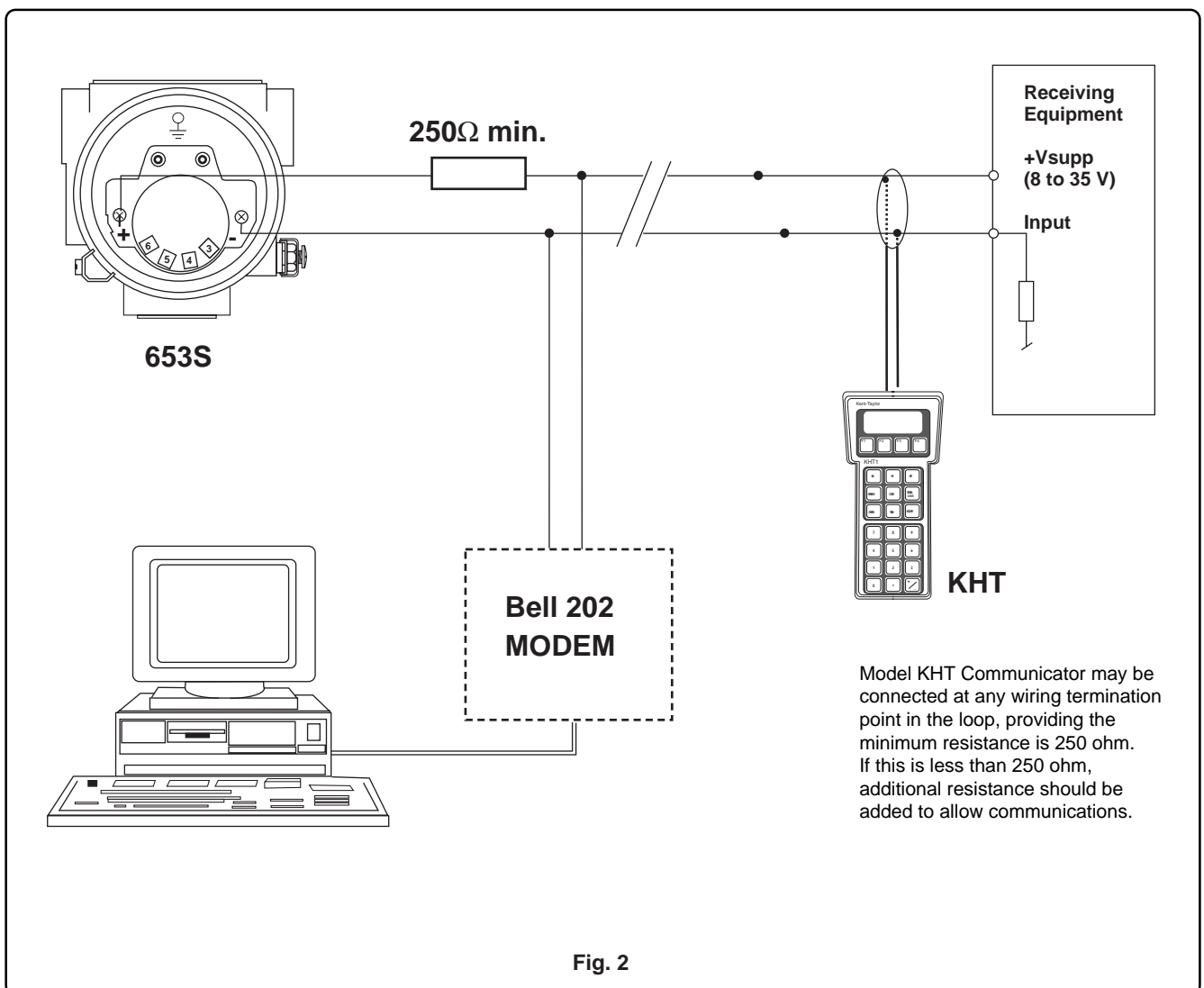

4 INSTALLATION

Electrical temperature sensors such as RTDs and thermocouples produce low-level signals proportional to the temperature. The model 653S temperature transmitter converts the low-level sensor signal into a standard 4-20 mA dc signal that is relatively insensitive to lead length and electrical noise. This current signal is then transmitted to the control room via two wires.

Figures 3 and 4 show recommended mounting for complete transmitter and sensor assemblies.

These mechanical and electrical installation considerations are intended to serve as guidelines for preparing the site and selecting transmitter options. Actual installation procedures are provided under Mechanical Installation and Electrical Installation later in this section.

The transmitter can be attached directly to the sensor as shown in Fig. 4. An optional mounting bracket (see Fig. 6 and 7) permits the transmitter to be mounted remotely from the sensors, either on a flat surface or attached to a 50 mm (2") pipe.

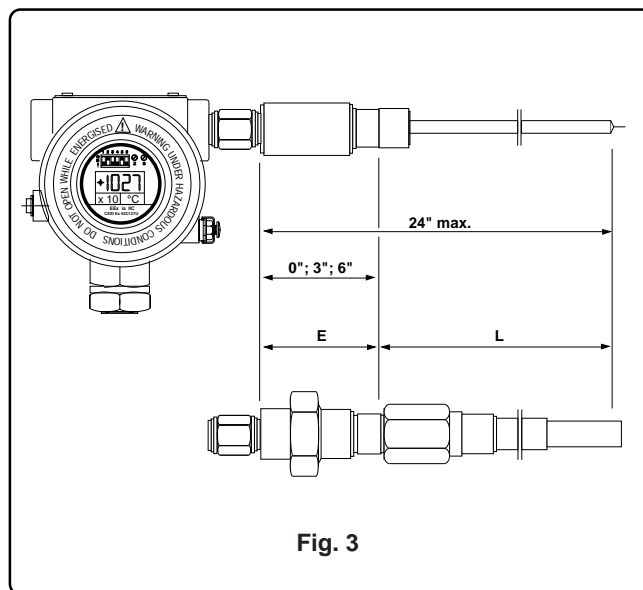

Fig. 3

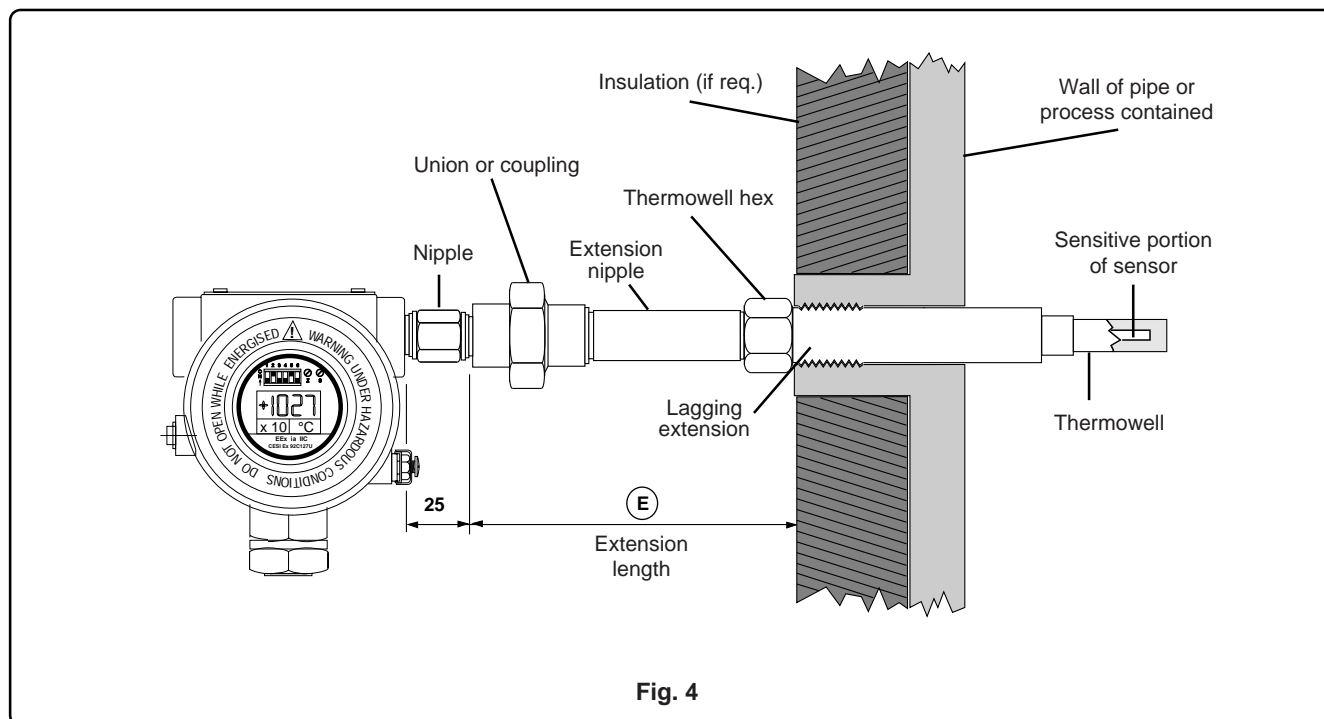

Fig. 4

Mounting stability is an important consideration. The transmitter, though rugged, may require separate support under high-vibration conditions, particularly if extensive thermowell lagging or long extension fittings are used. In such instances, pipe stand mounting using the optional mounting bracket is recommended.

The transmitter will operate within specifications for ambient temperatures in the range of -40 to $+85$ °C (-40 to $+185$ ° F).

Aside from ambient temperature variations, heat from the process is conducted from the thermowell to the transmitter housing. If the process temperature is near or beyond specification limits, thermowell lagging or an extension nipple should be used to isolate the transmitter from these high temperatures.



WARNING. Hazardous area installation

Ensure that the temperature of the transmitter and associated accessories does not exceed the values indicated on the Safety Marking Plate of the instrument, e.g., T6 (85°C) and T4 (135°C) according to the appropriate European Standards.

EXAMPLE:

Housing temperature rise for the installation illustrated is shown in Fig. 5.

Suppose the maximum ambient temperature is 40°C (104 °F) and the temperature to be measured is 540°C (1000 °F). The maximum allowable housing temperature rise is the rated specification limit (85°C) minus the existing ambient (40°C) it yields 45 K. As shown in Fig. 5, an "E" dimension of 3 inches (length recommended) will result in a housing temperature rise of 32 K; this would provide a safety factor of 13 K. A longer "E" dimension, such as 6 inches, would be desirable in order to reduce errors caused by transmitter temperature effect (rise 10 K only), although in that case, the transmitter may require extra support. Refer to the mounting information above. If a thermowell with lagging is used, the "E" dimension may be reduced by the length of the lagging.

The model 653S transmitter has been designed to resist attack by moisture and corrosives. O-ring seals protect the interior when the covers are installed. In humid environments, however, it is possible for moisture to accumulate in conduit lines.

Mount the transmitter at a high point in the conduit run, if possible. If the transmitter is mounted at a low point in the conduit run, the terminal compartments could fill with water. The transmitter should be mounted so that moisture from the conduits will not drain into the housing. In some instances a drain seal is advisable.

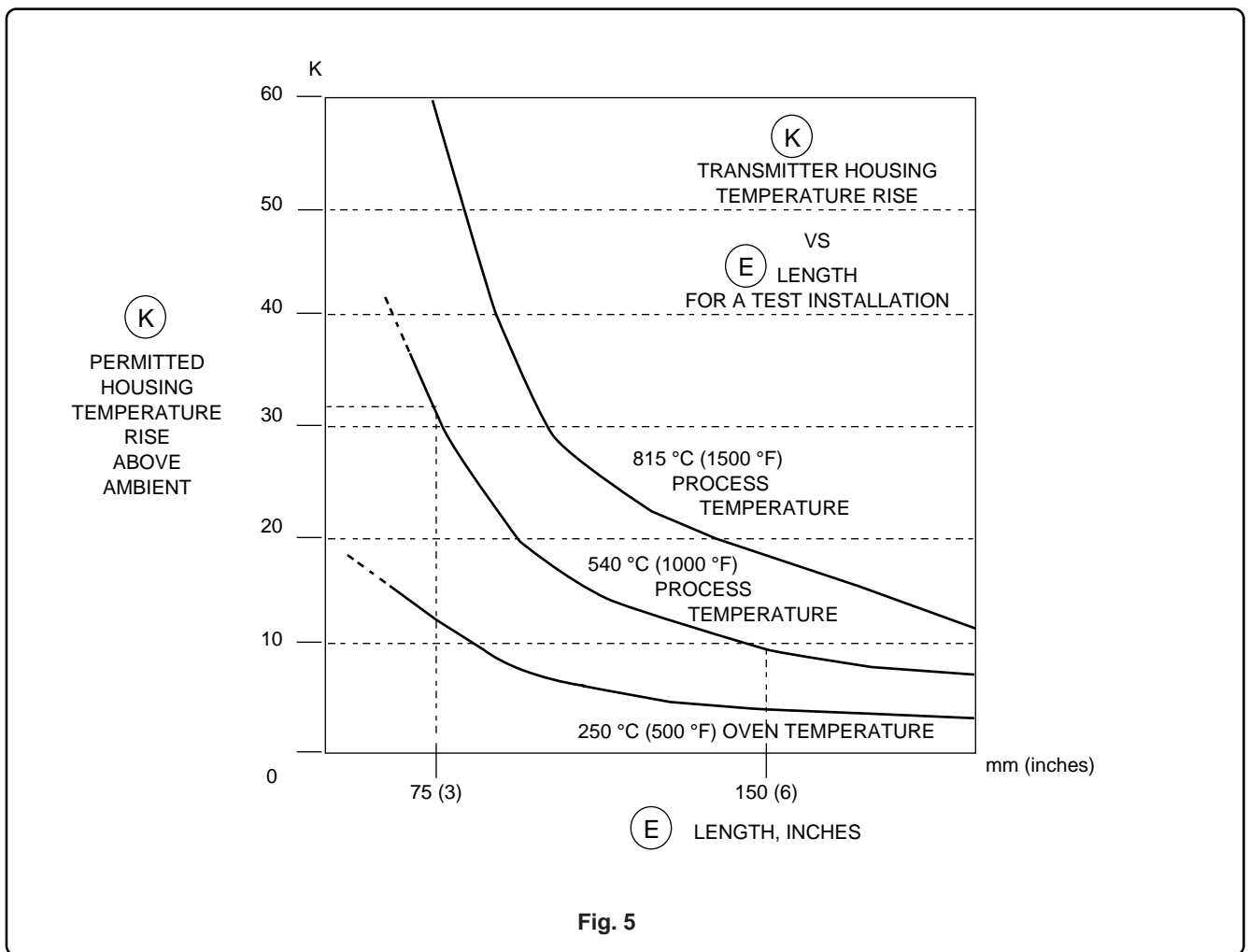

Fig. 5



WARNING. For installations in Hazardous Areas, i.e. areas with danger of fire or explosion, irrespective of the protection mode used, the installation must be carried out in accordance with local authority regulations.

5 ELECTRICAL CONNECTIONS

Two user connections are required: one to the remote sensor, the other to the signal line. Two connection ports, one for sensor the other for signal, are provided on the top of the housing, for cable glands or conduit fittings. The connection ports are protected by plastic plugs for transit purposes only.

WARNING - For Hazardous Location installations, at least five (5) threads on both conduit fittings and permanent proper metallic plug must be engaged in order for the transmitter to meet flameproof (explosion-proof) requirements.
If connections are made through one port only, the other must be stopped by a proper metallic plug to ensure the environmental protection degree and satisfy hazardous area regulations.

- Sensor connection

This connection can be accomplished by removing the cover. To ensure proper cable (from remote sensor) gland sealing use a single multi-core cable. The cores must be a maximum of 1.5 mm dia (16 AWG) each. Make the connections as indicated in fig. 8.

NOTE : for differential measurement where two input sensors are used, it is recommended a junction box with two inlets and one outlet grouping the connections to the transmitter in one single cable to ensure good sealing.

NOTE : for field strength applications over 10 V/m it is highly recommended to route the cable through solid conduit to retain EMI/RFI protection.

CAUTION Unless absolutely necessary, avoid the removal on site of the cover which gives access to the electronic circuitry. Although the electronics is fully tropicalized it should not be subjected to humidity for long periods.

- Signal connection

This connection can be accomplished by removing the cover. Make the connections to the terminal block as indicated in fig. 8. The internal output meter, when required, can be mounted simply by plugging it into the appropriate socket after the removal of the short circuit link.

WARNING - For installation in Hazardous Areas, i.e. areas with danger of fire and/or explosion, prior to making electrical connections, ensure compliance with safety information on the safety marking plate. Failure to comply with this warning can result in fire or explosion.

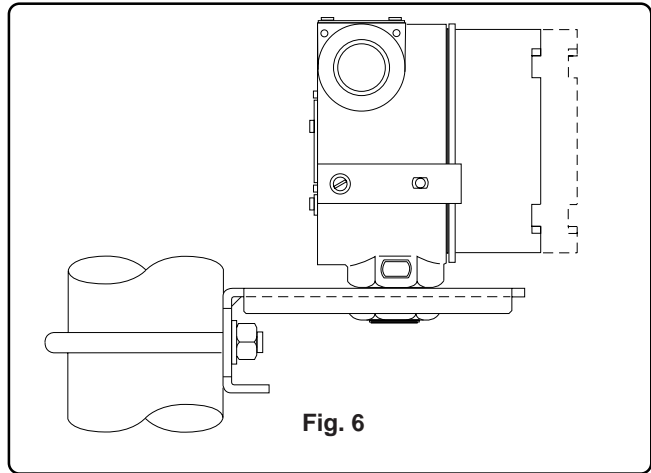

Fig. 6

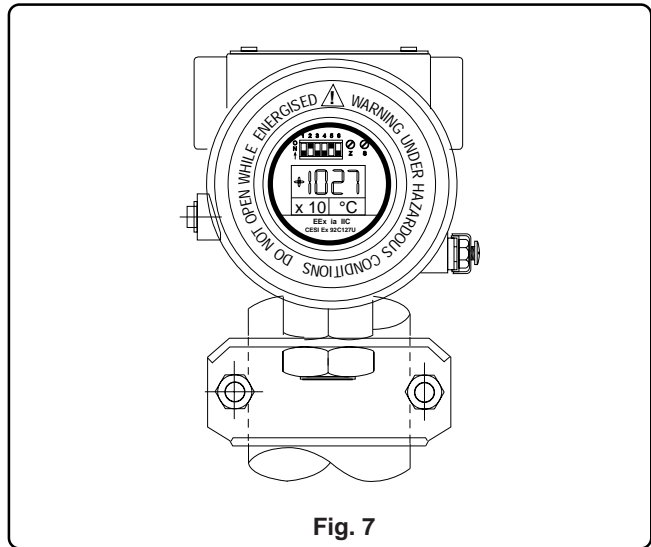
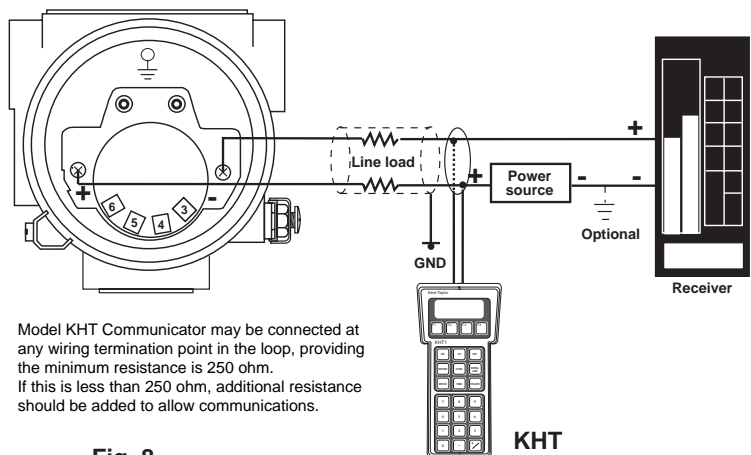

Fig. 7

The power to the transmitter is supplied over the signal wiring and no additional wiring is required. The signal wiring does not need to be shielded but the use of a twisted pair is highly recommended. Do not run the signal wiring in close proximity of power cable or high power equipment: use dedicated conduits or trays for signal wiring. Signal wiring may be ungrounded (floating) or grounded at any place in the signal loop. For intrinsically safe applications the wiring and grounding must follow the specific rules for this technique. The transmitter case may be grounded or ungrounded.

INPUT TYPE	TERMINAL CONNECTION
Termocouple and voltage	Terminal 5 = positive Terminal 4 = negative
Resistance thermometer and linear resistance	Terminal 3 and 6 = inputs Terminal 4 = 3rd wire (if any) Terminal 5 = 4th wire (if any)
Differential thermocouple	Terminal 6 = negative THC 1 and 2 Terminal 5 = positive THC 1 Terminal 4 = positive THC 2
Differential resistance thermometer	Terminal 5 and 6 = inputs RTD1 Terminal 3 and 5 = inputs RTD2

NOTE: DIFFERENTIAL MEASUREMENT COMPUTES RTD1 - RTD2 (THC1-THC2)



Model KHT Communicator may be connected at any wiring termination point in the loop, providing the minimum resistance is 250 ohm. If this is less than 250 ohm, additional resistance should be added to allow communications.

Fig. 8

6 ELECTRICAL REQUIREMENTS

The transmitter operates on a minimum voltage of 8 Vdc to a maximum of 35 Vdc and is protected against polarity inversion. The minimum voltage increases to 10 V dc when a digital LCD meter is fitted.

The total loop resistance, including optional remote indicator line (max 15 ohm), is indicated in the figure and expression below.

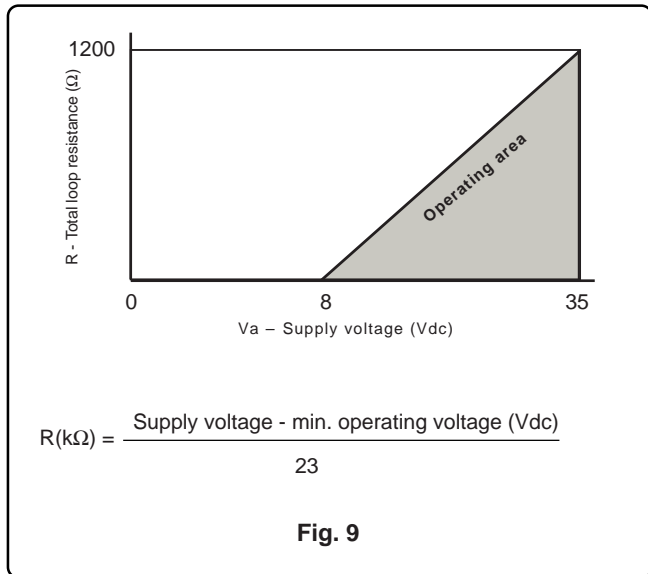

The total loop resistance is the sum of the resistance of all elements of the loop, including wiring, conditioning resistor, safety barriers and additional indicators (excluding the equivalent resistance of the transmitter).

7 CONFIGURATION AND CALIBRATION

Configuration

To change some user configurable transmitter parameters (e.g. "Range"), refer to CONF procedure as explained in the KHT (Release 4.0a) hand held communicator manual.

Calibration

Two different methods can be used to calibrate the 653S Smart Temperature transmitters:

- ii) using the Hand Held Communicator model KHT.
- iii) using the Personal Computer Configuration Software Package.

In both cases the following equipment is required:

- a) a mV signal generator (input) which should have an accuracy at least, three times better than the instrument accuracy
- b) a resistor (with accuracy as point "a")
- c) a digital multimeter (DVM), 4 digit at least
- d) a power supply unit (24 V dc nominal).

The calibration process is organized into two procedures; these may be accessed by the **4-20 Trim** dedicated functions, as described, e.g. in the KHT hand held communicator manual.

Preliminary operations

Before powering up the transmitter and commencing calibration, set up the electronics as follows:

- a) Disconnect all wires from the sensor, on the terminal block
- b) Connect the generator to the transmitter input following the instructions (the connections related to the sensor type are illustrated in fig. 8).

Note : For differential measurement, the transmitter output is positive if:

- mV / THC : input 1-3 is greater than input 1-2
- ohm / RTD : input 1-5 is greater than input 1-4

- c) Power on the transmitter, following the instructions for the minimum voltage required.

Calibration operations:

- d) Carry out the calibration procedure as explained in the KHT or Smart Configuration Program Manuals (i.e. TRIM 4 to 20 mA trim).

Note that calibration for a specified input range enhances the "Accuracy rating" performance. The value, stated in the specification sheet, refers to the standard factory calibration.

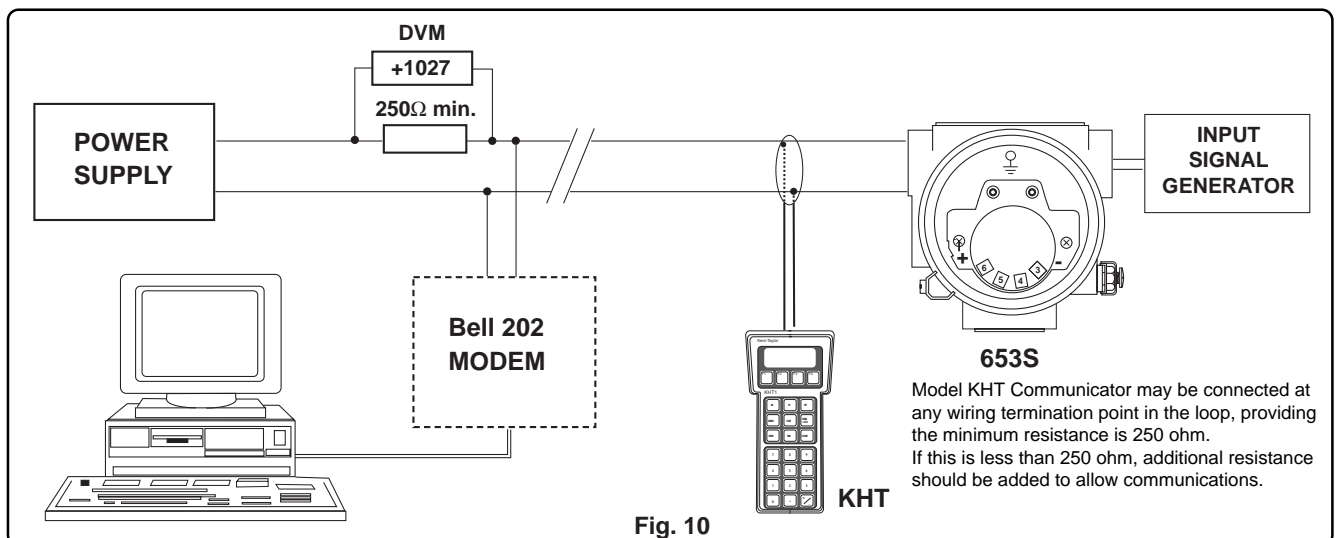

Model KHT Communicator may be connected at any wiring termination point in the loop, providing the minimum resistance is 250 ohm. If this is less than 250 ohm, additional resistance should be added to allow communications.

8 ASSEMBLING OF A TEMPERATURE SENSOR TO THE HOUSING

To fit an integral sensor to an existing 653S temperature transmitter (comprising top works complete of electronics and terminal block), proceed as follows:



Fig. 11



NOTE - Be sure that the electrical wires of the sensor are flexible (stranded) and 1 mm dia (AWG 20) max.

- 1) Remove the instrument from the mounting bracket.
- 2) Provide the sensor with a 1/2 NPT nipple and free cables of appropriate length (see fig. 11).
- 3) Insert the wires into the side hole (1/2 NPT threaded).
- 4) At the same time offer the sensor to the housing and screw in using a hexagonal spanner suitable for the 1/2 NPT nipple.
- 5) Connect the wires to the terminals, according to the sensor/ measurement type.



WARNING

For the Flameproof instrument version (EEx d) ensure, that the sensor is a flameproof type sensor as well, complying with the data of the Safety Marking plate of the transmitter.
(In case of doubt, please contact ABB Kent-Taylor).



WARNING - For installation of flame proof (EExd) instruments in Hazardous Areas, i.e. areas with danger of fire and/or explosion, do not remove any cover.
Failure to comply with this warning can result in fire or explosion.

9 ADDENDUM FOR METER OPTION

The LCD meter provides local indication of the transmitter output. The meter can be easily installed on the terminal block of the transmitter using an extended windowed cover to accommodate the meter. Fig. 12 shows the transmitter fitted with the cover for LCD meter.

The meter features a 3 1/2 digits liquid crystal display providing a direct indication of the transmitter output signal. It can display the output either in mA, percent of span, or engineering units. The zero and span adjustments and the decimal point setting switches on the meter front allow its correct calibration. A set of plastic labels, supplied with the meter, can be fitted in a recess below the indicator in order to display the multiplying factor and the engineering units in use.

For transmitters ordered with the LCD meter, the meter is installed and calibrated in the factory. The standard calibration/indication scale is 0 to 100%. If the meter is ordered and shipped separately the following instructions must be followed for mounting and calibration. The meter can be calibrated either before or after the installation.

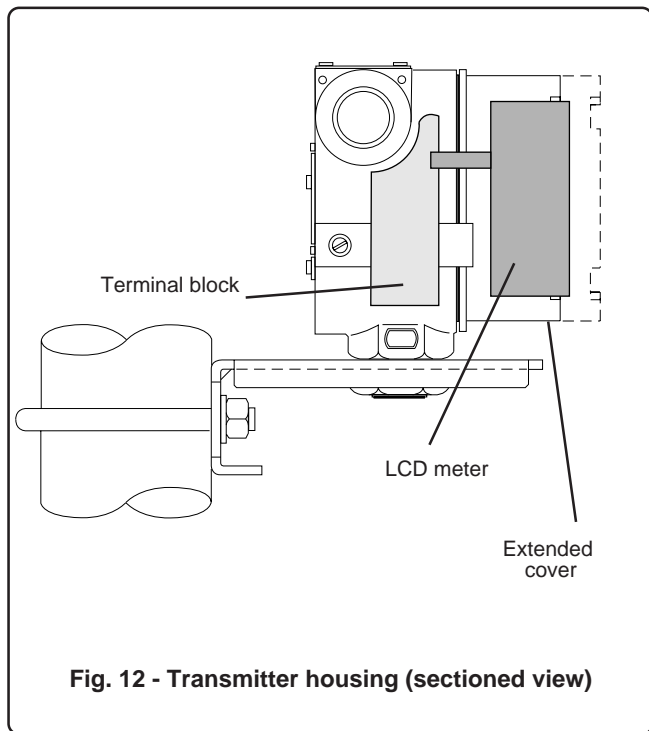

Fig. 12 - Transmitter housing (sectioned view)

Product Identification

Three labels are provided with the LCD digital meter:

- 1) in the lower part of the meter front a label indicates the type of safety protection with, if selected, the relevant certification number.
- 2) in the upper part of the reverse side, a label indicates the initial calibration range (usually 0 to 100% unless otherwise specified). If the meter is supplied already installed the label indicates the serial and tag identifier of the connected device.
- 3) in the lower part of the reverse side a label indicates the electrical limits allowed by the I.S. certification.

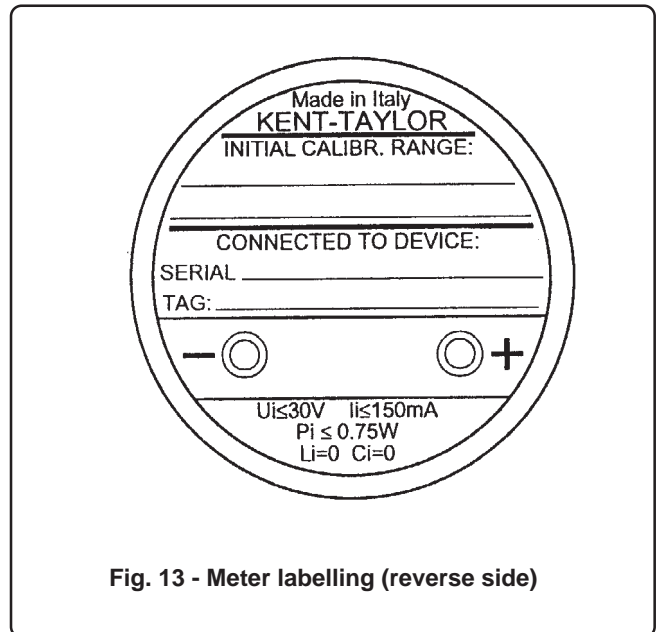

Fig. 13 - Meter labelling (reverse side)

Meter installation

To install (or to replace) the meter use the following procedure:

- 1) If the transmitter is part of a control loop, put the loop in manual.



WARNING - If the transmitter is not certified as Intrinsic Safety type (EEx-i), DO NOT REMOVE THE COVER in area classified as "HAZARDOUS LOCATIONS: CAN RESULT IN HAZARD OF FIRE AND EXPLOSION". Contact your Safety Dept. in order to establish a correct installation procedure.

- 2) Remove the cover.
- 3) Remove the link between terminal plugs.
- 4) Plug the meter (see fig. 14) and rotate as required for an viewing. The meter can rotate, in 15° steps, 270° degree clockwise and 75° counterclockwise (see fig. 15). Further rotation causes damage to the meter stop or of the "banana" connections and should be avoided. Note that considerable torque must be applied for 15° rotation.
- 5) Check that the O-ring gasket is properly in place, screw on the extended cover and tighten properly.

... 9 ADDENDUM FOR METER OPTION

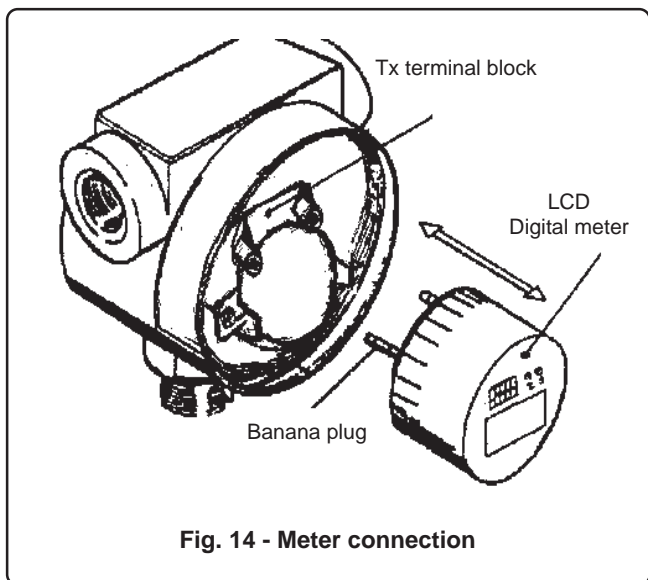
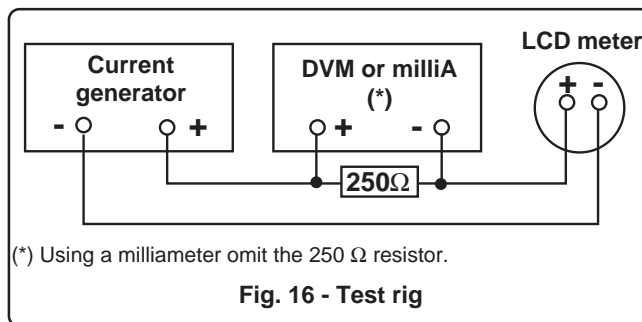

Fig. 14 - Meter connection



NOTE

If the meter should be removed, be careful to replace it immediately by another one or by the proper link provided. This operation is important for I.S. loop application, as, with the meter removed the loop continuity protection can drop a max. voltage of 4V.



(*) Using a milliammeter omit the 250 Ω resistor.

Fig. 16 - Test rig

Calibration procedure

The LCD meter can be calibrated either using a conventional current generator and an accurate milliammeter or utilizing the 653 as a current generator, in which case the meter can be calibrated after the fitting on the transmitter terminal block, using a calibrator to set the output current to the desired value. In the first case a suitable test rig should be used, as indicated in fig. 16. The accuracy of the milliammeter or of the DVM and the relevant measuring resistor (250 Ω) should be better than 0.03%.

The switches must be positioned as follows:

SW1	SW2	For ZERO adjustment, between
OFF	OFF	-1999 ÷ -1000
OFF	ON	-1000 ÷ 0
ON	OFF	0 ÷ 1000
ON	ON	1000 ÷ 1999

SW3	SW4	For SPAN adjustment, between
ON	ON	100 ÷ 1000
ON	OFF	1000 ÷ 2000
OFF	ON	2000 ÷ 3000
OFF	OFF	3000 ÷ 3998

SW5	SW6	For DECIMAL POINT position, like
ON	OFF	4.00 ÷ 19.99
OFF	ON	40.0 ÷ 199.9
OFF	OFF	400 ÷ 1999

Then proceed as follows:

- 1) Set the output current of the current generator to 4 mA on the milliammeter or 1 V. on the DVM. Alternatively, force the output of your transmitter to 4 mA.
- 2) Adjust the zero trimmer (Z) to read approximately the lower range value (LRV) on the digital meter.
- 3) Set the output current to 20 mA, on the milliammeter or 5 V. on the DVM. Alternatively force the output of the transmitter to 20 mA.
- 4) Adjust the span trimmer (S) to read approximately the upper range value (URV) on the digital meter.
- 5) Repeat the points 1) 2) to read exactly (± 0.1) the LRV.
- 6) Repeat the points 3) 4) to read exactly (± 0.1) the URV.
- 7) Complete the calibration procedure by fitting the multiplication factor label (if any) in the left recess below the display and the engineering unit label in the right recess (see fig. 15).

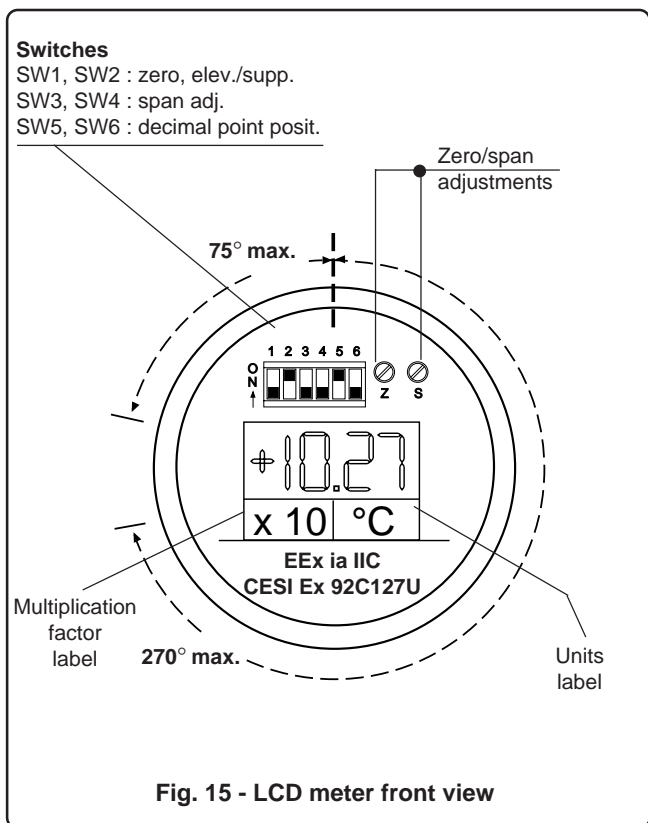

Fig. 15 - LCD meter front view



TROUBLE SHEET

WARRANTY REPAIR REPAIR ORDER

Rejection or discrepancy reports

Copy attached Not available

● IDENTIFICATION

Customer

Purchase order No.

Plant

Name of person to contact

Instrument tag No.

Model

Serial No.

● OPERATING CONDITIONS

Specify location, environmental conditions, type of service and approximate number of operating hours or date of installation if known.

[Empty box for operating conditions]

● REASON FOR RETURN

[Empty box for reason for return]

Trouble found during : Installation Commissioning Maintenance
At start up On service

Shipping information for the return of the equipment

Material returned for factory repair, should be sent to the nearest ABB Kent -Taylor Service Center, transportation charges prepaid by the Purchaser.

Please enclose this sheet duly completed to cover letter and packing list

Date Signature Originator



The Company's policy is one of continuous product improvement and the right is reserved to modify the specifications contained herein without notice.

IM/653S Rev 2

ABB Instrumentation spa

Via Statale 113
22016 Lenno (Como)
Italia
Tel. (0344) 58111
Facsimile (0344) 56278

ABB Automation Ltd.

Howard Road
St. Neots, Cambs.
England PE19 3EU
Tel. (01480) 475321,
Facsimile (01480) 217948

ABB Automation Inc.

125 East County Line Road
Warminster PA
18974-4995 USA
Tel. (215) 674-6693/6320/6777
Fax (215) 674-7184