

FPD212

Dual-chamber orifice fitting

Measurement made easy

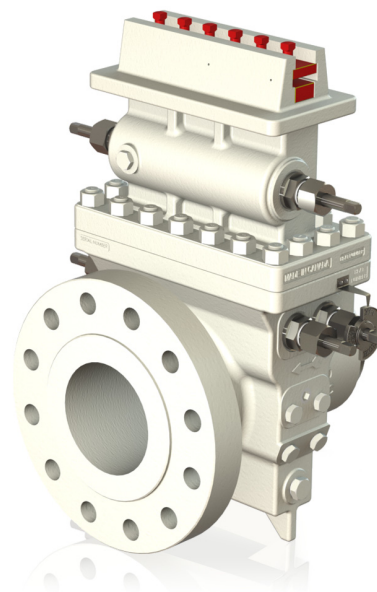

Introduction

ABB's FPD212 dual-chamber orifice fitting is a proven system for safely and quickly inspecting and changing orifice plates in conformance with strict Oil & Gas industry guidelines.

These operating instructions provide installation, operation and maintenance procedures for the FPD212 dual-chamber orifice fitting.

For more information

Further publications for the FPD212 dual-chamber orifice fitting are available for free download from www.abb.com/measurement or by scanning this code:



Contents

1 Health & Safety	3
1.1 Document symbols	3
1.2 Safety precautions	3
1.3 Potential safety hazards	3
1.4 Product recycling and disposal (Europe only)	3
1.5 Lifting and handling	4
1.5.1 Lifting / moving products in crates and on pallets	4
1.5.2 Lifting / moving meter runs	5
1.5.3 Lifting / moving orifice fittings	6
2 Operation	7
3 Key operating parts	8
4 Orifice plate – removal	9
5 Orifice plate – inspection	11
6 Orifice fitting – quick inspection and assessment	12
7 Scheduled teardown maintenance	12
8 Orifice plate – replacement	13
9 Greasing procedure	16
10 Preservation and storage	16
11 Specification	17
Notes	18

1 Health & Safety

1.1 Document symbols

Symbols that appear in this document are explained below:



DANGER – Serious damage to health / risk to life

This symbol in conjunction with the signal word 'DANGER' indicates an imminent danger. Failure to observe this safety information will result in death or severe injury.



WARNING – Bodily injury

This symbol in conjunction with the signal word 'WARNING' indicates a potentially dangerous situation. Failure to observe this safety information may result in death or severe injury.



CAUTION – Minor injuries

This symbol in conjunction with the signal word 'CAUTION' indicates a potentially dangerous situation. Failure to observe this safety information may result in minor or moderate injury. The symbol may also be used for property damage warnings.



NOTICE – Property damage

This symbol indicates a potentially damaging situation. Failure to observe this safety information may result in damage to or destruction of the product and / or other system components.



IMPORTANT (NOTE)

This symbol indicates operator tips, particularly useful information or important information about the product or its further uses. The signal word 'IMPORTANT (NOTE)' does not indicate a dangerous or harmful situation.

1.2 Safety precautions

Be sure to read, understand and follow the instructions contained within this manual before and during use of the equipment. Failure to do so could result in bodily harm or damage to the equipment.



WARNING – Bodily injury

Pressurized equipment

Installation, operation, maintenance and servicing of pressurized equipment must be performed:

- by suitably trained personnel only
 - in accordance with the information provided in this manual
 - in accordance with relevant local regulations
-

1.3 Potential safety hazards



WARNING – Bodily injury

To ensure safe use when operating this equipment, the following point must be observed:

- Orifice fittings and their components present both heavy lifting and tip-over hazards. Operators must wear suitable PPE at all times and have strategies in place for safely lifting, moving and storing orifice fittings and their components.

Safety advice concerning the use of the equipment described in this manual or any relevant Material Safety Data Sheets (where applicable) can be obtained from the Company, together with servicing and spares information.



NOTICE – Property damage

The soft-seat valve seal design does not require lubrication through the grease port. Attempting to lubricate the FPD212 orifice fitting equipped with a soft-seat inner slide valve causes the inner O-ring seal to be ejected from the dovetail groove resulting in valve failure.

1.4 Product recycling and disposal (Europe only)



IMPORTANT (NOTE) For return for recycling, please contact the equipment manufacturer or supplier for instructions on how to return end-of-life equipment for proper disposal.

1.5 Lifting and handling

This product requires mechanical lifting devices and techniques. All safety activities associated with lifting techniques and equipment must be in accordance with local laws and the receiving company's HSE policies and procedures, and shall be followed without exception. Extreme care must be exercised throughout the operation to prevent both injury to personnel and damage to the meter. Proper rigging and lifting techniques must be followed. Do not stand under suspended loads. Improper handling may cause injury and / or damage. SAFETY FIRST.

This product is delivered to its destination in a wooden crate or strapped to a wooden pallet and is easily moved using a standard forklift. There are scenarios, however, where a meter run or fitting must be moved without the aid of a frame. In both cases, care must be taken to assess the weight of the package and ensure that the machinery and lifting aids are appropriate to the items being handled. Crate, pallet and / or meter run weights are documented on the commercial invoice or packing slip accompanying the shipment.

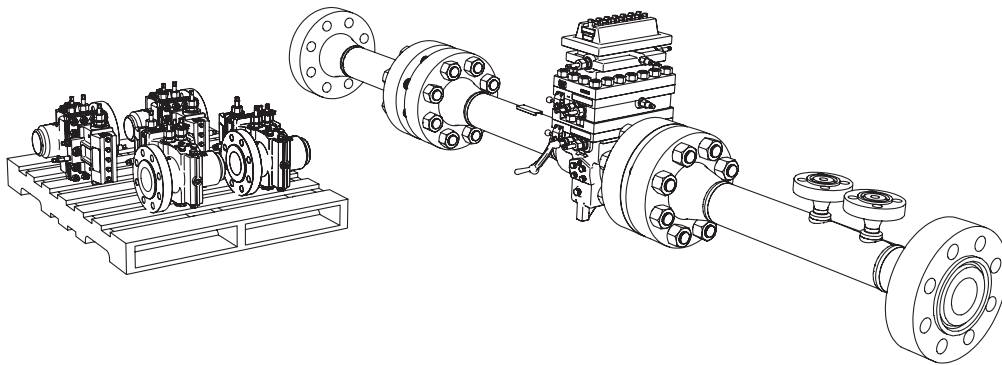
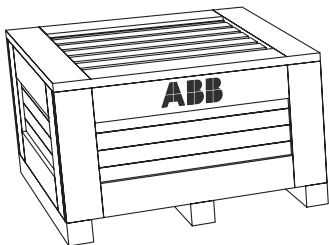

Fig. 1.1 Product packaging

1.5.1 Lifting / moving products in crates and on pallets

Select an appropriate forklift based on the weight of the package being handled. Use fork extensions if necessary.

Center the forks so the load is evenly distributed. Ensure the load is balanced and secure prior to lifting. Use extra strapping to secure unstable loads.

Drive the forks into the load as far as possible. Avoid contact with any parts of the load that may extend past the edge of the pallet. Tilt the load back slightly, then lift.

Keep the load as low as possible while traveling, keep an even pace and avoid fast starts and sudden stops.

1.5.2 Lifting / moving meter runs

Select an appropriate forklift and lifting straps based on the weight of the meter run being handled. Position the forks as narrowly as possible to create a single lifting point.

Determine the meter run's center of gravity and position the lifting straps as shown in Fig. 1.2, ensuring the meter run is balanced when lifted. Ensure the lifting straps are wrapped in opposing directions to prevent the meter run from rotating and swinging.

Slide the ends of the lifting straps over the forks, positioning them as close to the forklift body as possible, while ensuring the meter run does not make contact with the forklift.

Tilt the load back slightly, then lift. Keep the forks as low as possible while traveling, keep an even pace and avoid fast starts and sudden stops.

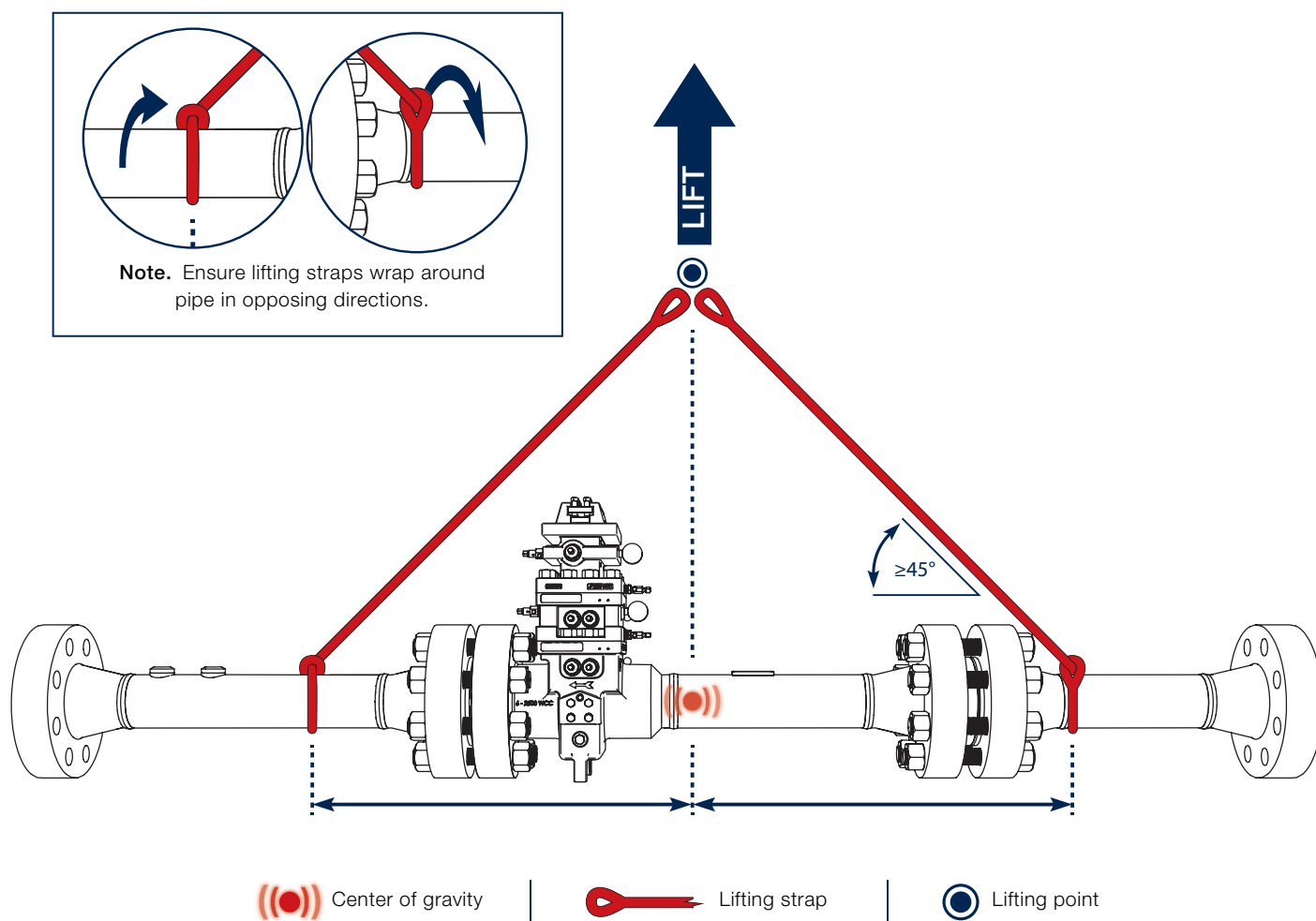

Fig. 1.2 Lifting meter runs



IMPORTANT (NOTE)

Fig. 1.2 does not reflect all configurations. Centers of gravity may not be exactly as shown.

1.5.3 Lifting / moving orifice fittings

Select an appropriate forklift and lifting strap based on the weight of the fitting being handled. Position the forks as narrowly as possible to create a single lifting point.

Wrap the lifting strap around the fitting, under the shoulder of the upper chamber as shown in Fig. 1.3.

Slide the end of the lifting strap over the forks, positioning the strap as close to the forklift body as possible while ensuring the fitting does not make contact with the forklift. Adjust as necessary.

Tilt the load back slightly, then lift. Keep the forks as low as possible while traveling, keep an even pace and avoid fast starts and sudden stops.

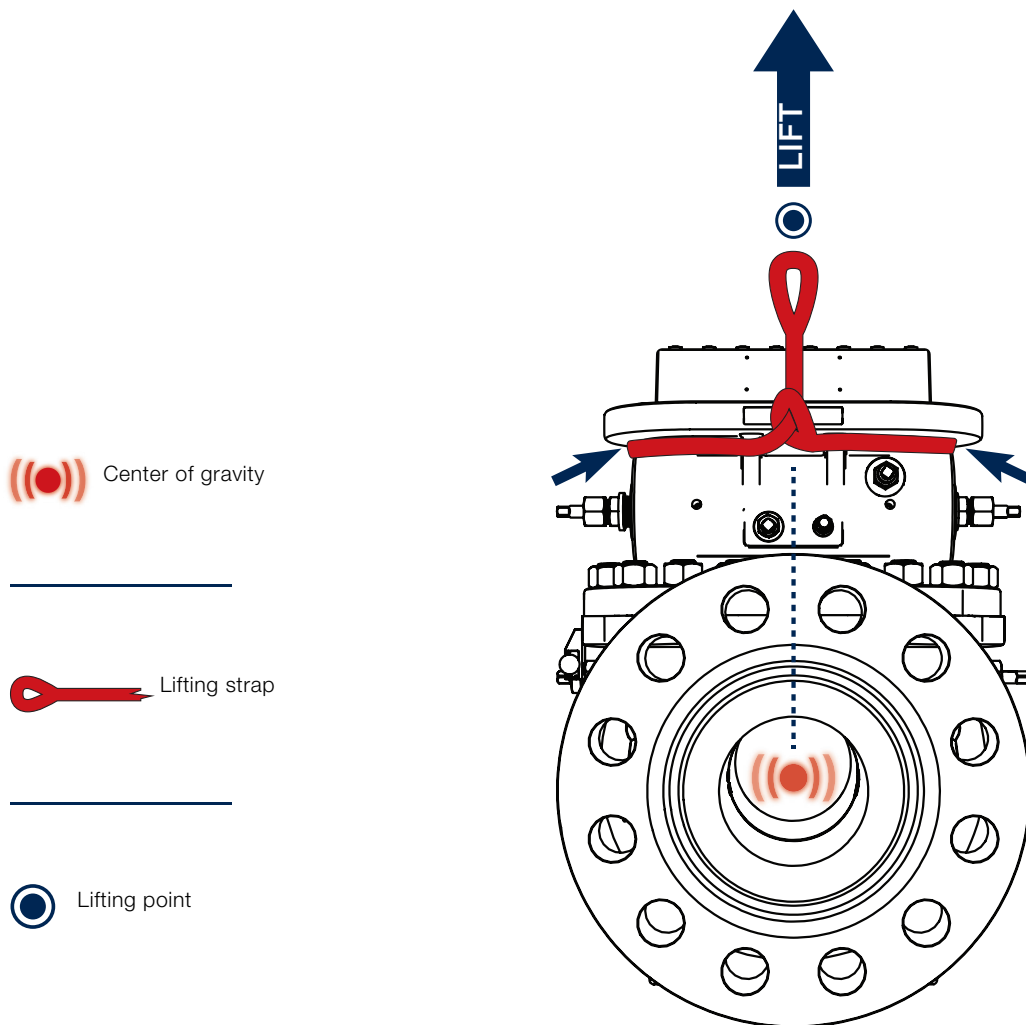

Fig. 1.3 Lifting orifice fittings

i IMPORTANT (NOTE)

Fig. 1.3 does not reflect all configurations. Centers of gravity may not be exactly as shown.

2 Operation

The FPD212 dual-chamber orifice fitting enables accurate placement of an orifice plate in a pipeline, together with easy removal and replacement, without interrupting the flow or dismantling the pipeline. The flow of a gas or liquid through the orifice plate creates the differential pressure that is measured and used to calculate the flow rate through the pipeline.

Referring to Fig. 2.1, the orifice fitting is in normal metering mode when:

- the plate carrier and orifice plate are in the lower chamber, concentric to the pipeline
- the inner slide valve is closed
- the equalizer valve is closed
- the bleed valve is closed
- the upper chamber is at atmospheric pressure
- the clamping bar is tight

Pressure sensors installed in the lower chamber's meter taps read the differential pressure across the orifice plate and transmit the readings to a flow computer or chart recorder.

Orifice plate condition is critical to accurate metering. The orifice plate must be removed and inspected for damage, general wear and particulate build-up regularly. Prior to beginning the orifice plate removal procedure, the operator must confirm that the clamping bar is tight and the bleeder valve is fully close.

During normal operation, only the lower chamber is pressurized. Atmospheric pressure in the upper chamber is necessary for proper functioning of the inner slide valve.

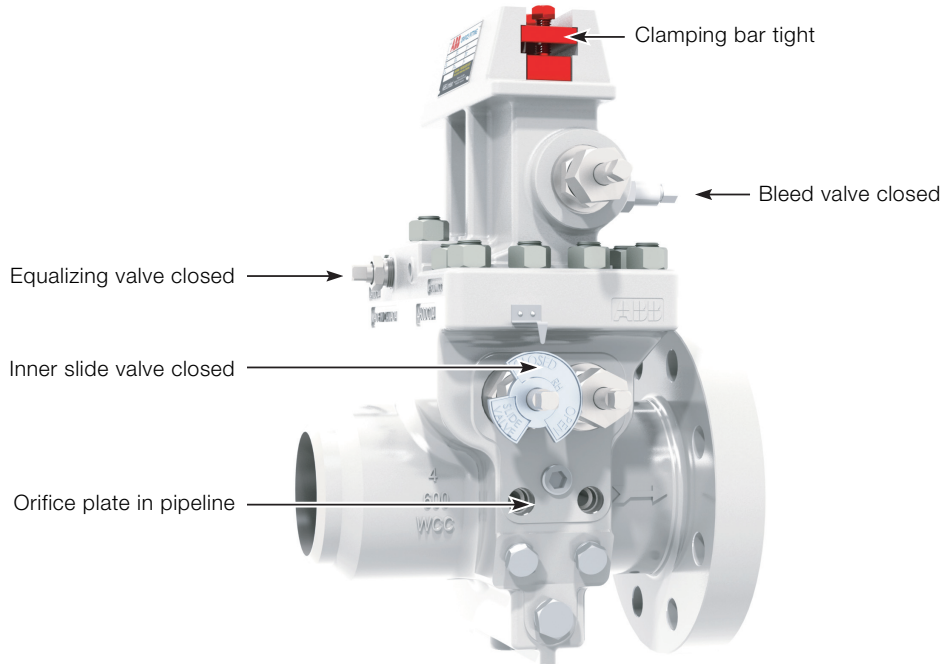
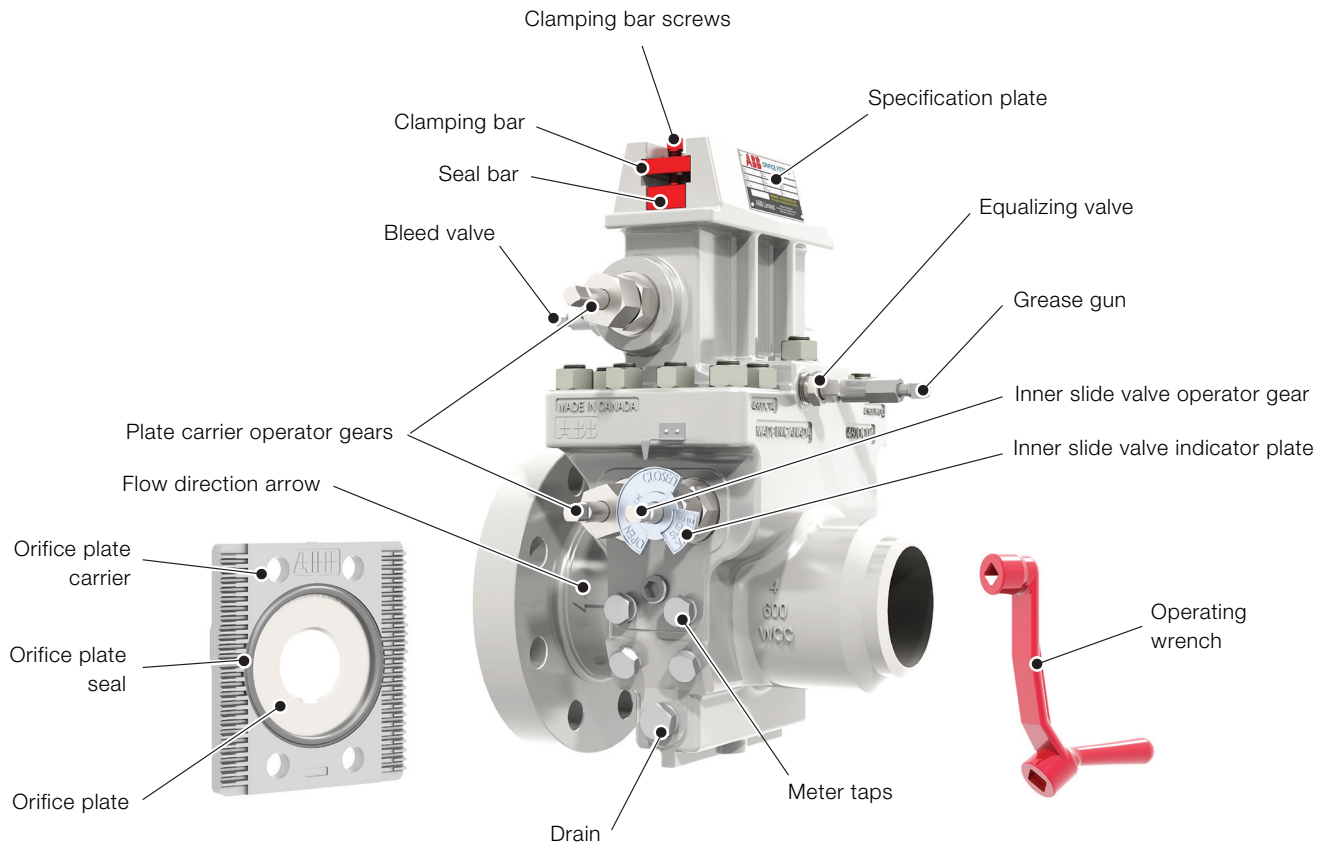

Fig. 2.1 Normal metering mode

3 Key operating parts

The FPD212 dual-chamber orifice fitting is operated by relatively few parts, all of which are controlled with the use of the included operating wrench. The spatial separation of the operating parts, together with the visual differences between them, reduce the chances of operator error.



4 Orifice plate – removal



WARNING – Bodily injury Ensure the clamping bar is tight and the bleed valve is fully closed before proceeding.

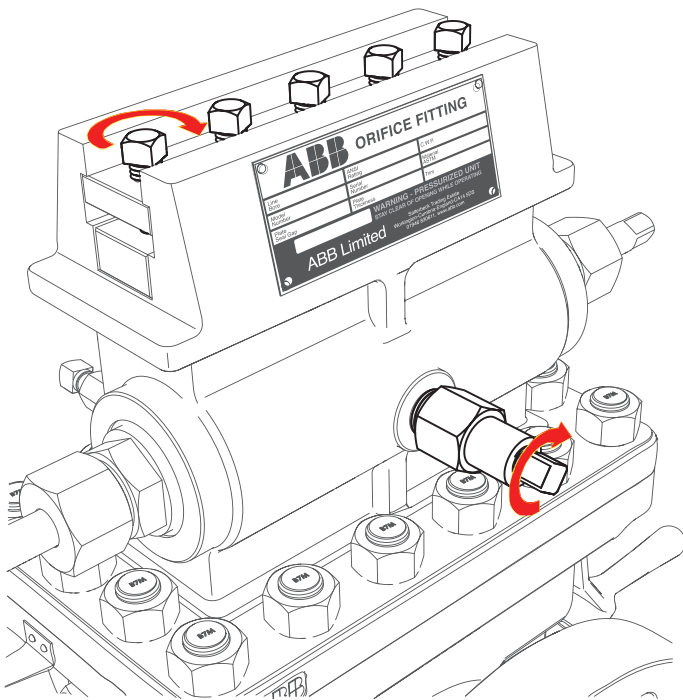

To remove the orifice plate:

1. Slowly open the equalizer valve.

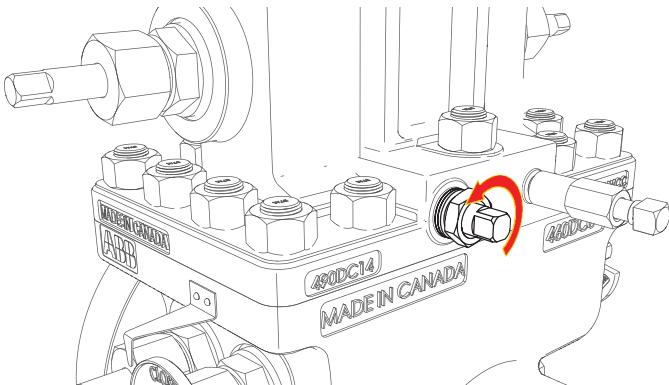

2. Open inner slide valve.

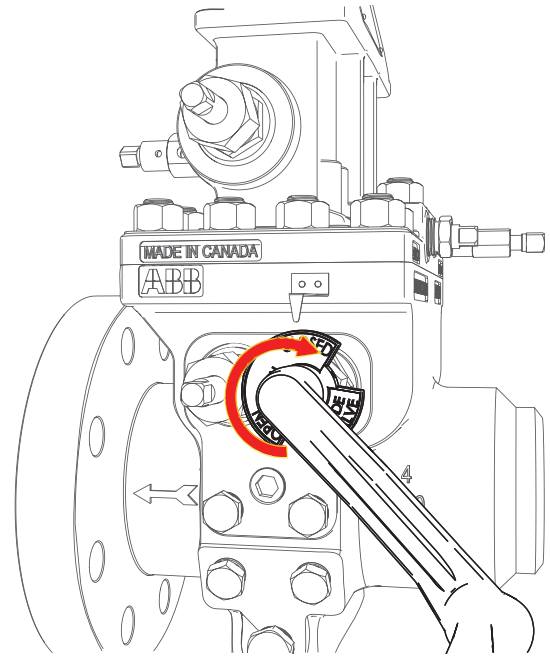

3. Raise orifice plate carrier with operator gears.

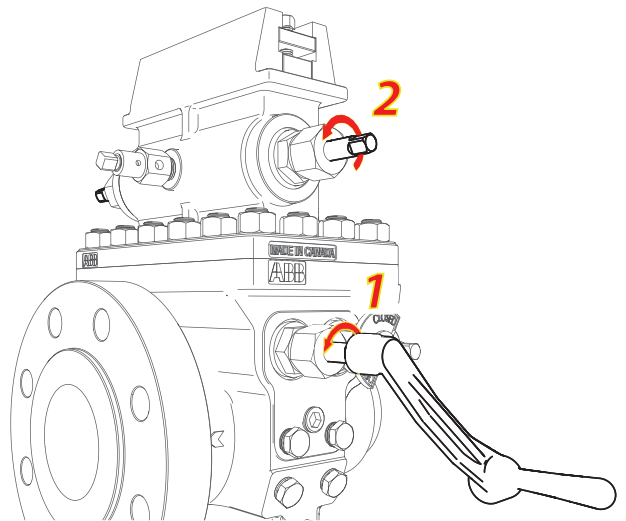

4. Close inner slide valve.

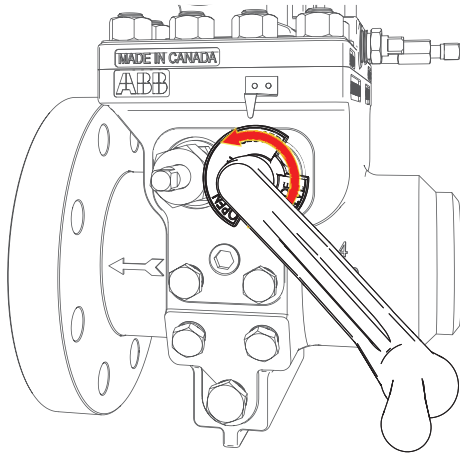

WARNING – Bodily injury Ensure inner slide valve is fully closed before proceeding.

5. Close equalizer valve.

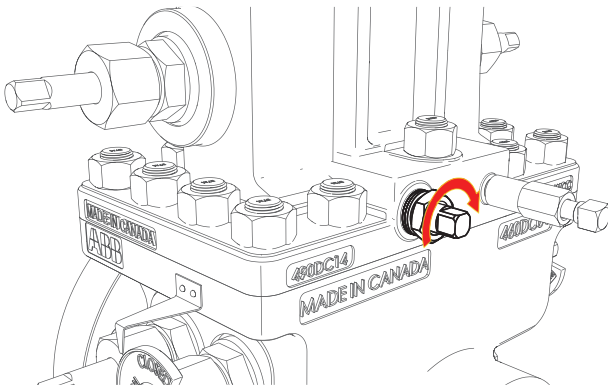

WARNING – Bodily injury Ensure equalizer valve is fully closed before proceeding.

6. Open bleed valve.

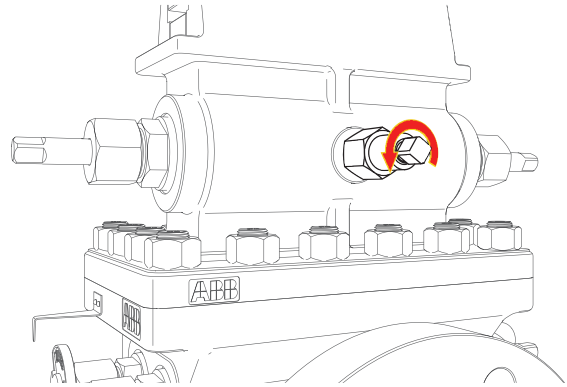

7. Perform greasing procedure – see Section 9, page 16.

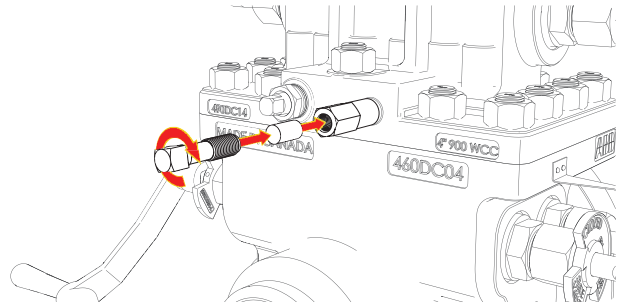

8. Loosen clamping bar.

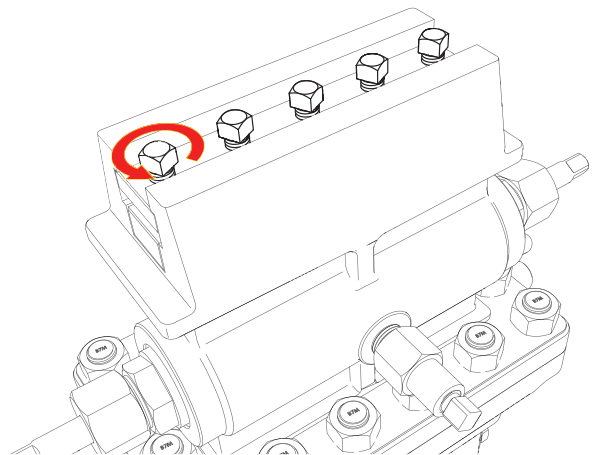

9. Dislodge seal bar with plate carrier.

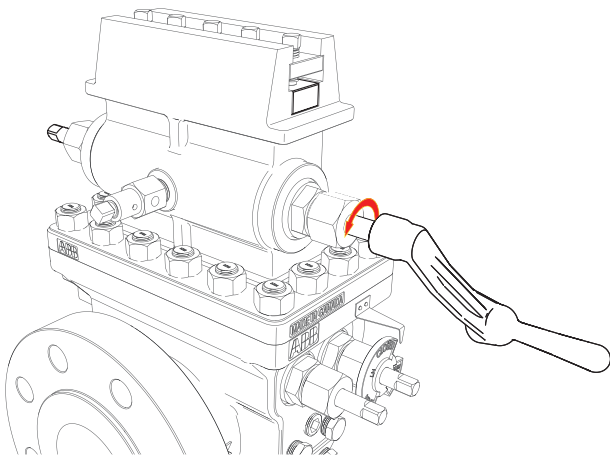

10. Remove clamping and seal bars, rotate orifice plate carrier up through opening.

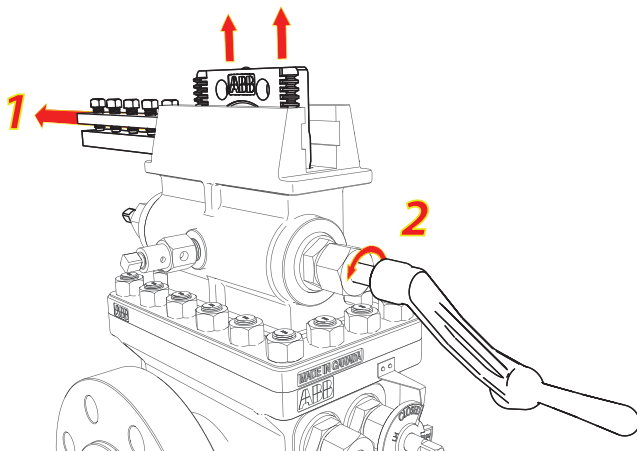

5 Orifice plate – inspection

Regular orifice plate inspections are crucial to measurement accuracy. ABB recommends that the orifice plate is removed from the orifice fitting and inspected monthly. AGA-3 / API 14.3 sections 2.4.1 and 2.4.2 outline orifice plate parameters that can be affected by service conditions. Damage, excessive wear and build-up can lead to a reduction in flow meter accuracy.

Pay particular attention to dirt, grease or ice accumulation, pitting due to corrosion, nicks, dings and other impact damage, as well as general wear and erosion of the normally sharp bore edges. Replace the orifice plate as necessary.

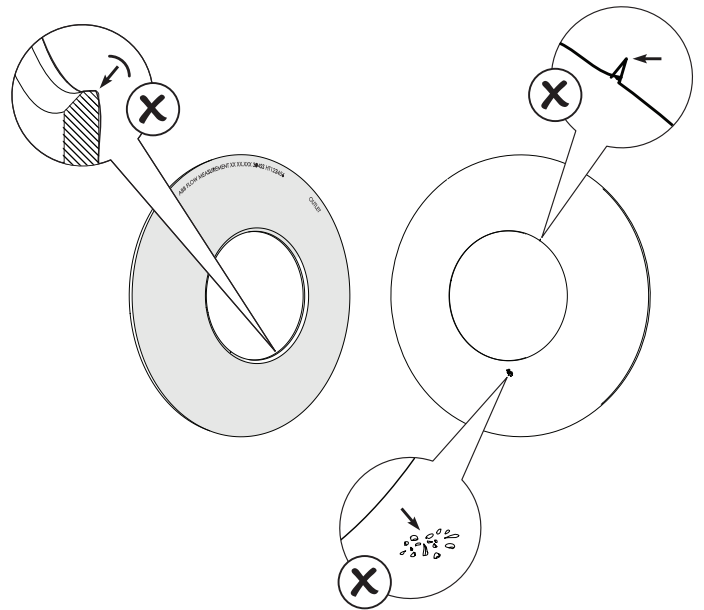

Fig. 5.1 Examples of unacceptable damage to the orifice plate

Orifice plate seals must also be inspected to reduce the possibility of bypass. Pay attention to dirt or grease accumulation, cracks, tears or cuts and swelling. Replace seals as necessary.

6 Orifice fitting – quick inspection and assessment



WARNING – Bodily injury DO NOT open the inner slide valve to inspect the lower chamber if the upper chamber is open and the fitting is under process pressure.

When the clamping and seal bars have been removed from the orifice fitting and the upper chamber is open, visually inspect the interior of the fitting.

Pay attention to the condition of the interior surfaces of the orifice fitting, the pinion gear, seal bar face and O-ring. Excessive corrosion, fluid build-up or other visible damage may indicate the need for more extensive maintenance and replacement of parts. Similarly, excessive resistance when turning gear shafts during operation may indicate the need for the replacement of parts.

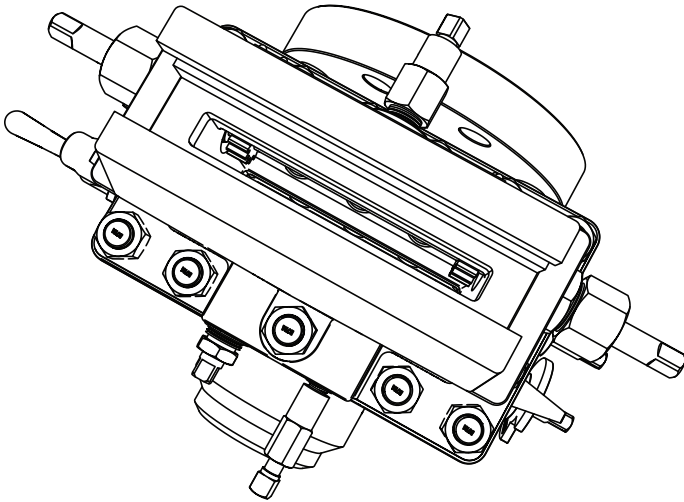

Fig. 6.1 Top view of orifice fitting (clamping and seal bars removed)

7 Scheduled teardown maintenance

Both measurement accuracy and orifice fitting performance in general can benefit from periodic maintenance. ABB recommends that maintenance is performed every two years or earlier if deemed necessary.

1. De-pressurize the process line.



WARNING – Bodily injury Ensure the process line is de-pressurized before removing the upper chamber from the orifice fitting body. Failure to de-pressurize could result in serious injury or death.

2. Remove the upper chamber.
3. Visually inspect all interior surfaces of the orifice fitting body for excessive build-up or corrosion.
4. Inspect gear shafts for broken or bent teeth. Replace as necessary.
5. Inspect valve seat surfaces for abrasion or corrosion. Replace as necessary.



IMPORTANT (NOTE) Step 6 is applicable only to fittings fitted with grease-type inner slide valves.

6. Replace the valve seat grease in the grease track.
7. Replace the valve strip and all accessible O-rings (including valve seat O-rings on soft-seat units).
8. Remove the drain plugs and remove all accumulated debris from the lower chamber.
9. Inspect all differential pressure tap holes for build-up. Clean as necessary.
10. Refit the upper chamber.

8 Orifice plate – replacement



WARNING – Bodily injury Steps 11 to 14 **MUST** be performed before re-pressurizing the process line. Failure to follow this procedure could result in serious injury or death.

11. Ensure the orifice plate is in the upper chamber.
12. Ensure the inner slide valve is closed.
13. Ensure the equalizing and bleed valves are closed.
14. Ensure the seal and clamping bars are in place and tightened down.
15. Repressurize the process line.

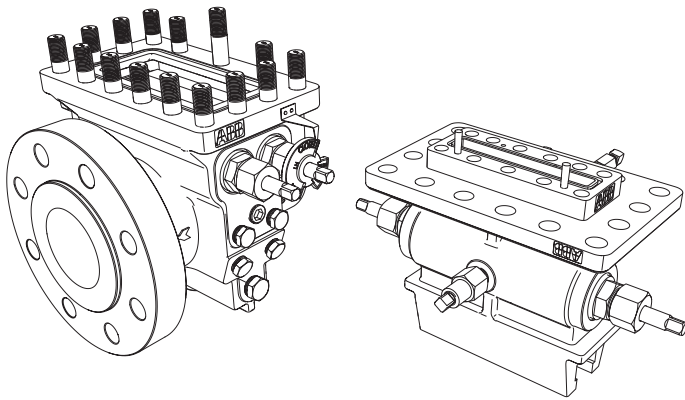

Fig. 7.1 Orifice fitting dismantling



NOTICE – Property damage When refitting the orifice plate, proper positioning of the orifice plate and plate carrier is crucial to both correct operation and metering accuracy.

To refit the orifice plate:

1. Align the orifice plate in the orifice plate carrier and insert orifice plate carrier into top opening, ensuring correct positioning as shown.

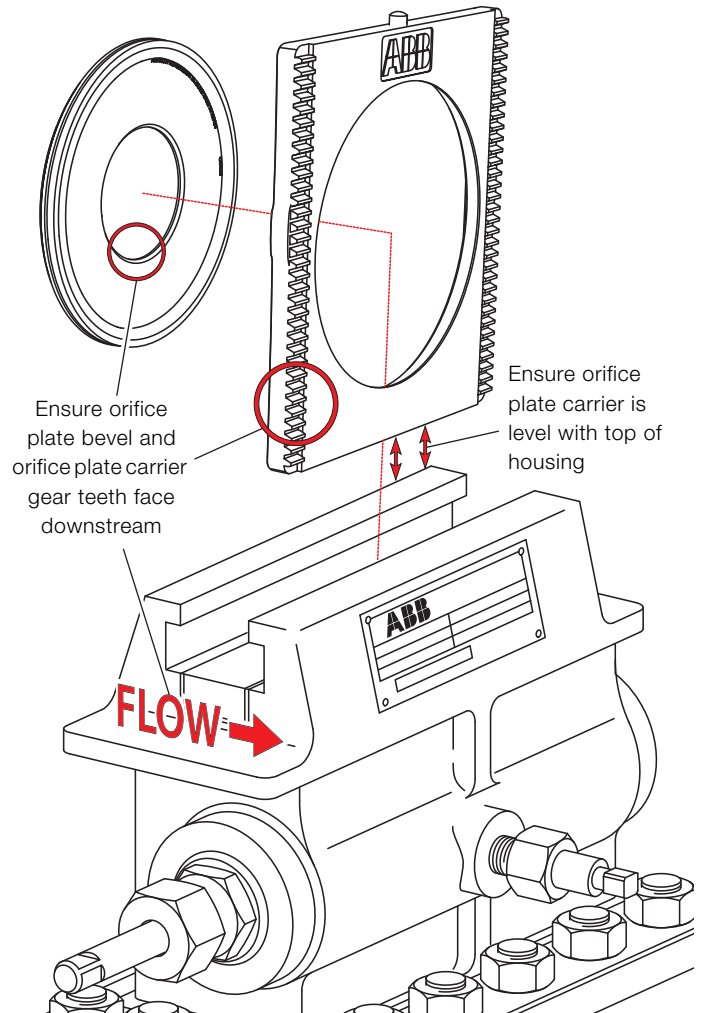

NOTICE – Property damage During step 2, do not lower orifice plate carrier onto inner slide valve.

2. Close bleed valve.

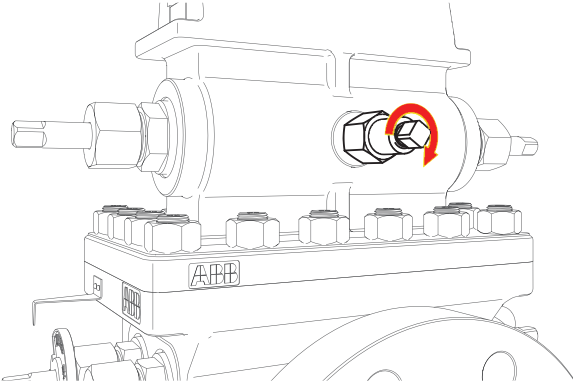

3. Lower orifice plate carrier into upper chamber.

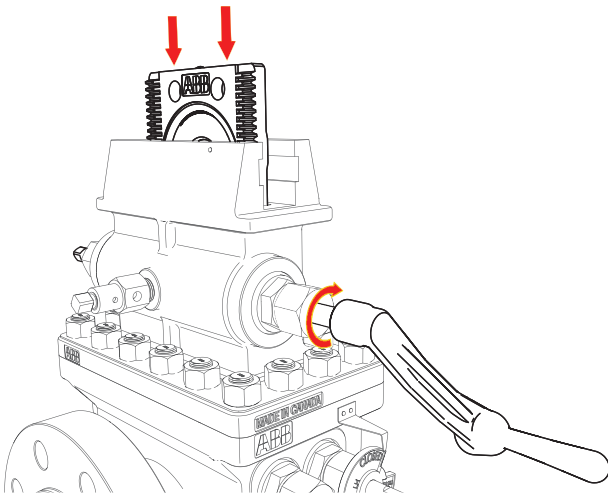

4. Install seal and clamping bars.

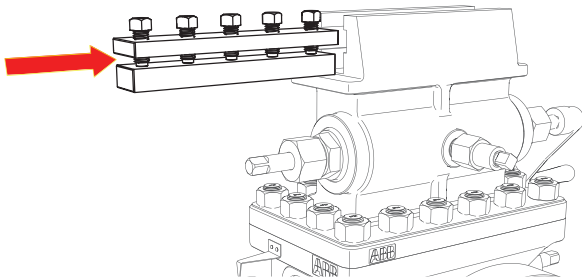

5. Tighten clamping bar screws.

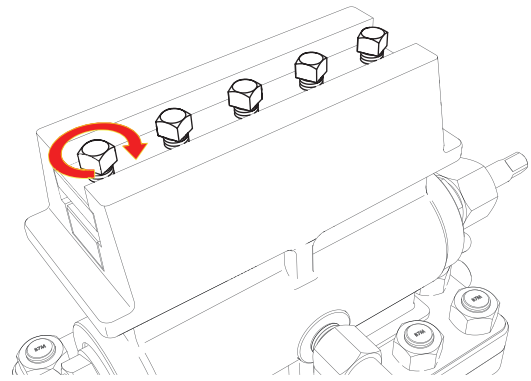

6. Slowly open equalizer valve.

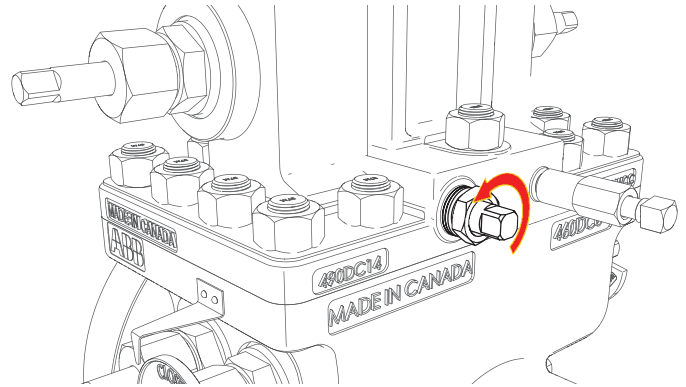

7. Open inner slide valve.

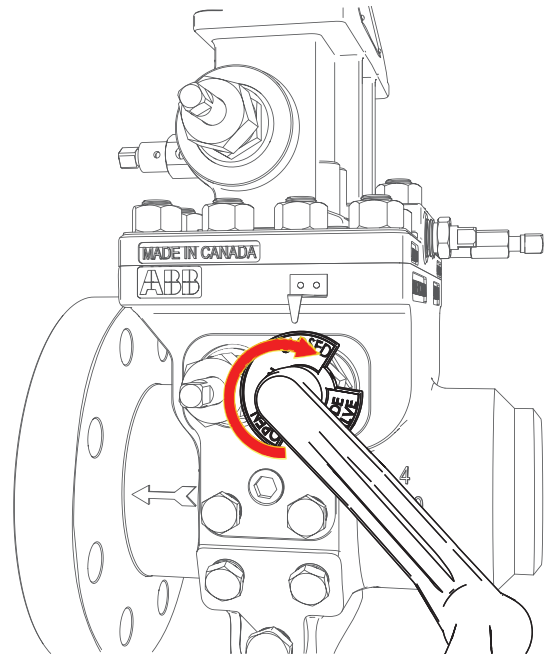

8. Lower plate carrier into bottom chamber.

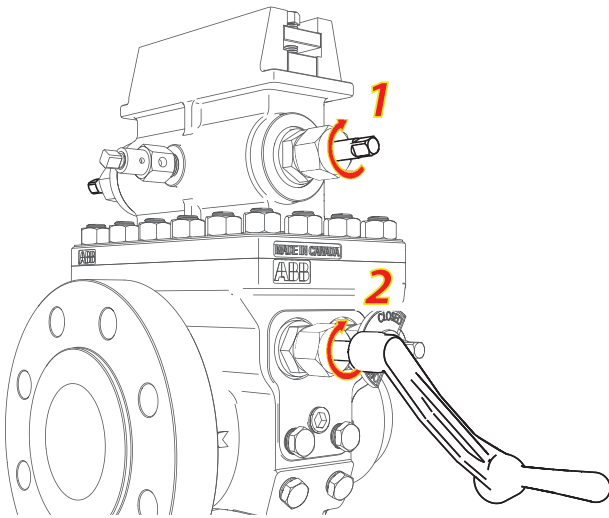

9. Close inner slide valve.

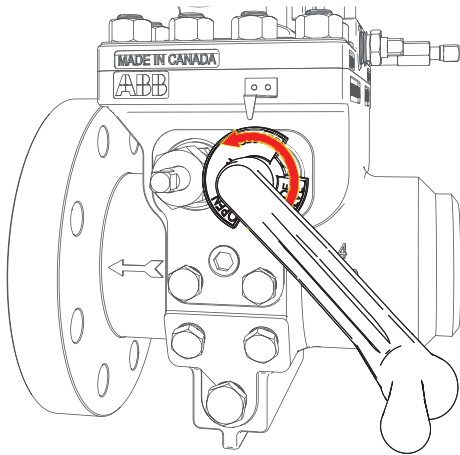

WARNING – Bodily injury Ensure inner slide valve is fully closed before proceeding.

10. Close equalizer valve.

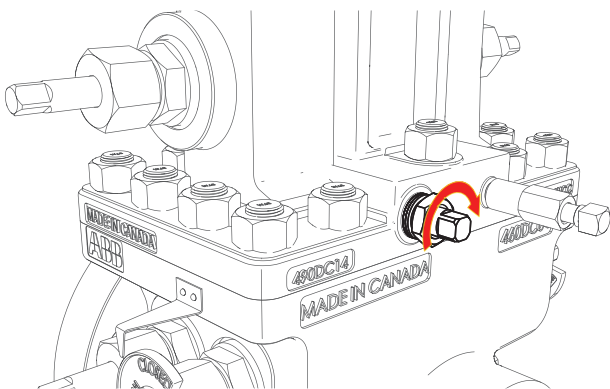

WARNING – Bodily injury Ensure equalizer valve is fully closed before proceeding.

11. Open bleed valve.

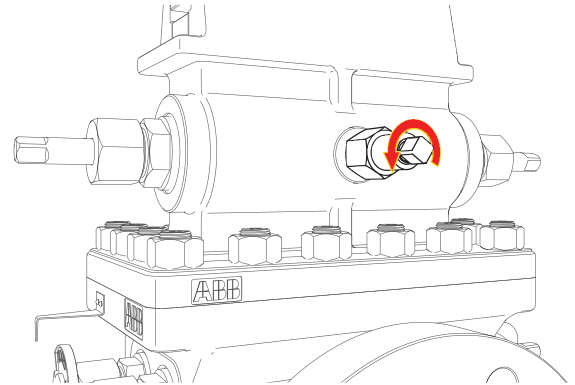

12. Perform greasing procedure – see Section 9, page 16.

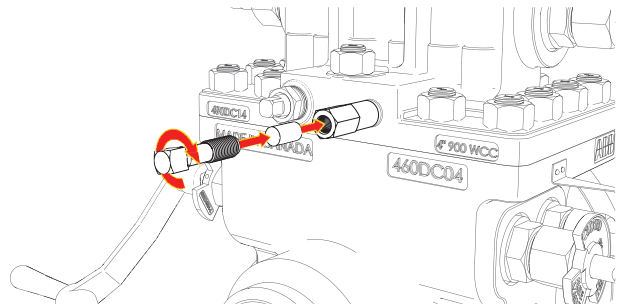

13. Close bleed valve.

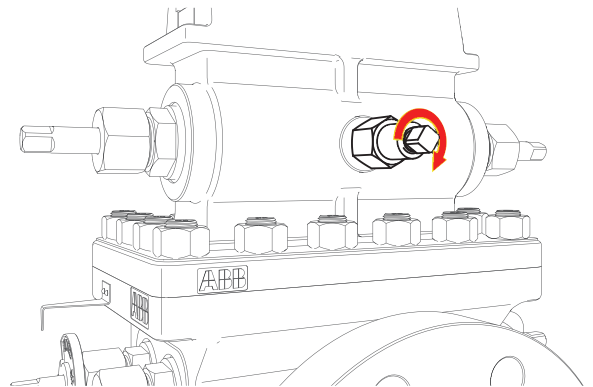

9 Greasing procedure

! NOTICE – Property damage This procedure is not applicable to orifice fittings equipped with the soft-seat valve seal design. Attempting to lubricate an FPD212 orifice fitting equipped with a soft-seat inner slide valve causes the inner O-ring seal to be ejected from the dovetail groove resulting in valve failure.

The metal-to-metal grease seal design requires lubrication on a regular basis. For the procedure to be successful, a pressure differential across the inner slide valve is required, with the chamber immediately below the valve having a higher pressure and forcing the valve strip up against the seat. The double ball grease check valve prevents process pressure from coming through the grease port. For best results, use only valve seal grease supplied by ABB and recommended for the applicable service.

1. Ensure that the inner slide valve and equalizer valve are fully closed.
2. Open the bleed valve and allow the upper chamber to de-pressurize. A pressure differential now exists between the lower and upper chambers, and the inner slide valve is ready to be greased.
3. Remove the threaded stem from the grease gun assembly. Insert one stick of grease.
4. Replace the grease gun stem and turn in slowly so as not to rupture the grease channel seal.

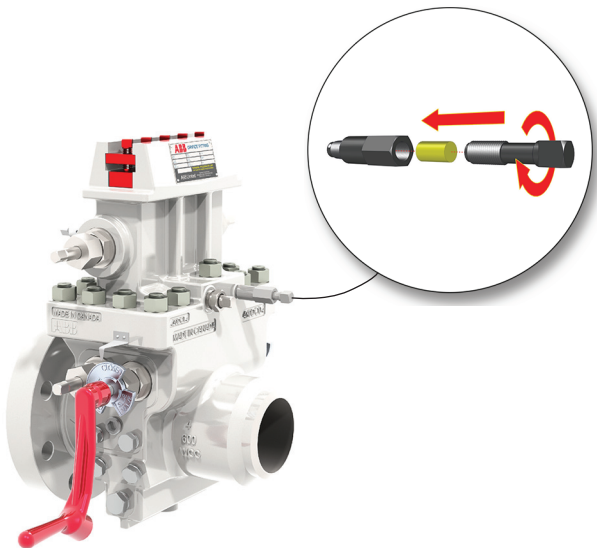

5. Repeat steps 3 and 4 if additional grease is required. Larger fittings require more grease.
6. Close the bleed valve.

10 Preservation and storage

Take the following measures to preserve and store orifice fittings that are not currently in service:

Store in dry conditions, preferably indoors to prevent rust and corrosion.

Fit the end caps supplied with the fitting.

Apply rust inhibitor inside the bore every 3 to 6 months.

Remove orifice plate and seals from the seal gap and ensure soft-seat inner slide valves remain in the open position during storage. Soft-seat units require no additional maintenance during storage. Do not apply valve seal grease to soft-seat units.

For grease-type units, apply valve seal grease every 90 days to prevent hardening of the sealant medium. Ensure grease-type valves remain in the closed position during storage.

Hydrostatic testing is required before entering service if stored for more than 1 year. Replace / re-lubricate seals as required.

11 Specification

Body configuration

- Flange x flange
- Flange x weld
- Weld x weld

Flanges to FF, RF and RTJ are available in the following formats:

- ANSI 16.5 or 16.47
- Techlok and SPO
- Grayloc®
- API 6A
- or to specific client specification

Design codes

- ASME B31.8 Gas Transmission And Distribution Piping
- NACE MR-01-75
- ASME B31.1 Power Piping
- ASME B31.3 Liquid Petroleum Transportation Piping Systems
- PED 97/23/EC Pressure Equipment Directive

Measurement standards

- ISO 5167
- API MPMS 14.3.2 (AGA Report No. 3)

Standard materials of construction

Body casting

- ASTM A216 WCP, WCC
- ASTM A352 LCC
- ASTM A351 CF8M
- ASTM A995 Gr.4A, Gr.6A
- Other materials are available on request

Internal components

- Stainless steel 316
- Stainless steel A351 CF8M
- Carbon steel AISI430

Pressure tappings

- 1 or 2 sets per side; 1/2 in. NPT female

External bolting

- ASTM A194 Gr.4 (Zinc coated)
- ASTM A320 L7 (Zinc coated)
- Other materials are available on request, including optional coatings such as PTFE, Xylan and Xylar

Seals

Seal bar

- HNBR O-ring (standard); gasket (optional)

Shafts

- PTFE packing (standard); HNBR O-ring (optional)

Inner valves

- Grease seal (standard); HNBR O-ring (optional)

Orifice plate

- Type 'K' 2000 edition formed HNBR seal on a 316 SS retainer ring
- Dual ring HNBR O-rings standard on a 316 SS retainer ring
- PTFE snap seal two-piece virgin PTFE assembly

Orifice plates

- Industry-standard orifice plate thicknesses as per the guidelines set out within ISO 5167 and API 14.3.

Maximizing performance

- To ensure absolute metering accuracy, it is recommended that industry practice is followed and meter tubes are purchased and manufactured to complement the orifice fitting. This ensures concentricity between the pipe and the fitting and eliminates uncertainties associated with misalignment.

ABB can supply the following items for a complete metering solution:

- orifice fitting with meter tube including straightening vane / profiler
- DP transmitters and process transmitters
- flow computer and enclosure
- spare parts for service and commissioning
- product service training

Temperature rating

- As ratings of material and flanges fitted

Pressure rating

Size in. (mm)	ANSI pressure class (fully-rated)
2 (50) to 12 (300)	150, 300, 600, 900, 1500, 2500
14 (350) to 24 (600)	150, 300, 600, 900, 1500

Note. For other sizes, contact ABB.

DS/FPD212-EN Rev. A

Contact us

ABB Limited

Process Automation

Oldends Lane
Stonehouse
Gloucestershire GL10 3TA
UK
Tel: +44 (0)1453 826661
Fax: +44 (0)1453 829671

ABB Inc.

Process Automation

125 E. County Line Road
Warminster
PA 18974
USA
Tel: +1 215 674 6000
Fax: +1 215 674 7183

www.abb.com

Note

We reserve the right to make technical changes or modify the contents of this document without prior notice. With regard to purchase orders, the agreed particulars shall prevail. ABB does not accept any responsibility whatsoever for potential errors or possible lack of information in this document.

We reserve all rights in this document and in the subject matter and illustrations contained therein. Any reproduction, disclosure to third parties or utilization of its contents in whole or in parts – is forbidden without prior written consent of ABB.

Copyright© 2015 ABB
All rights reserved



Sales



Service