

ABB PROCESS ANALYTICS

The Company

ABB Process Analytics specializes in the engineering, manufacture, sale and support of high quality, highly functional, analytical instrumentation for on-line analysis of process streams.

ABB Process Analytics is committed to quality leadership in the on-line analyser industry. The Company-wide, world-wide commitment is well expressed in the **quality statement** for ABB Process Analytics:

'We will conform to requirements and deliver defect-free products on time, to satisfy the needs of our internal and external customers.'

Use of Instructions



Warning.

An instruction that draws attention to the risk of injury or death.



Caution.

An instruction that draws attention to the risk of damage to the product, process or surroundings.



Note.

Clarification of an instruction or additional information.



Information.

Further reference for more detailed information or technical details.

Although **Warning** hazards are related to personal injury, and **Caution** hazards are associated with equipment or property damage, it must be understood that operation of damaged equipment could, under certain operational conditions, result in degraded process system performance leading to personal injury or death. Therefore, comply fully with all **Warning** and **Caution** notices.

Information in this manual is intended only to assist our customers in the efficient operation of our equipment. Use of this manual for any other purpose is specifically prohibited and its contents are not to be reproduced in full or part without prior approval of Technical Communications Department, ABB Process Analytics.

Health and Safety

To ensure that our products are safe and without risk to health, the following points must be noted:

1. The relevant sections of these instructions must be read carefully before proceeding.
2. Warning labels on containers and packages must be observed.
3. Installation, operation, maintenance and servicing must only be carried out by suitably trained personnel and in accordance with the information given.
4. Normal safety precautions must be taken to avoid the possibility of an accident occurring when operating in conditions of high pressure and/or temperature.
5. Chemicals must be stored away from heat, protected from temperature extremes and powders kept dry. Normal safe handling procedures must be used.
6. When disposing of chemicals ensure that no two chemicals are mixed.

Safety advice concerning the use of the equipment described in this manual or any relevant hazard data sheets (where applicable) may be obtained from the Company address on the back cover, together with servicing and spares information.

CONTENTS

Section	Page
1 INTRODUCTION	1
1.1 Documentation	1
1.2 System Hardware	2
1.3 Principle of Operation	2
2 PREPARATION	3
2.1 Checking the Instrument Type	3
2.1.1 Wall-mounted Instruments	3
2.1.2 Panel-mounted Instruments	3
3 MECHANICAL INSTALLATION	3
3.1 Siting Requirements	3
3.2 Mounting	4
3.2.1 Wall/Pipe-mounted Instruments	4
3.2.2 Panel-mounted Instruments	5
4 ELECTRICAL CONNECTIONS	6
4.1 Connections – General	6
4.1.1 Cable and Gland Specifications	6
4.1.2 Relay Contact Protection and Interference Suppression	7
4.2 Wall-mounted Instrument Connections	8
4.3 Panel-mounted Instrument Connections	10
4.4 Selecting the Mains Voltage	12
4.4.1 Wall/Pipe-mounted Instruments	12
4.4.2 Panel-mounted Instruments	12
5 CONTROLS AND DISPLAYS	13
5.1 Displays	13
5.2 Switch Familiarization	13
6 OPERATION	14
6.1 Instrument Start-up	14
6.2 Operating Page	14
6.2.1 Operating Page Error Messages	14
7 PROGRAMMING	15
7.1 Access to Secure Parameters	15
7.2 Set Up Outputs Page	16

1 INTRODUCTION

1.1 Documentation

Documentation for the EXFG Oxygen Analyzer System is shown in Fig. 1.1.

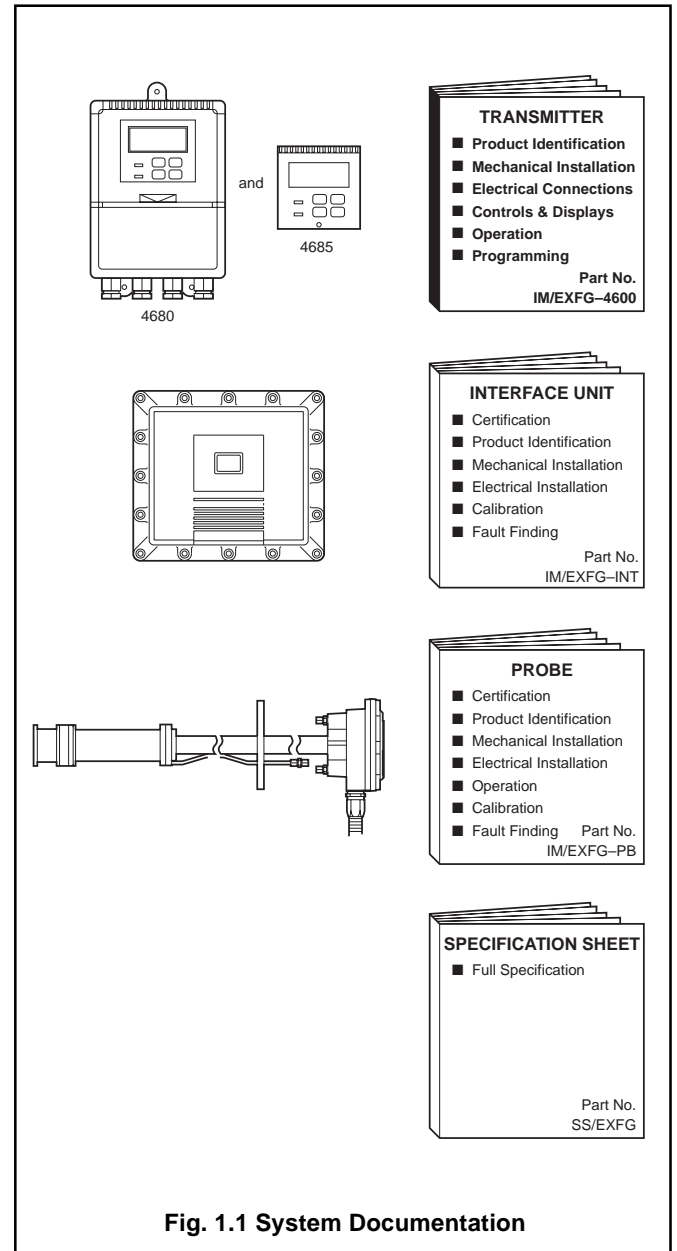

Fig. 1.1 System Documentation

...1 INTRODUCTION

1.2 System Hardware – Fig. 1.2

The 4680 and 4685 transmitters are part of the EXFG Oxygen Analyzer System which measures oxygen content and temperature within a gas flue. The 4680/500 model is a wall-mounted instrument and the 4685/500 model is a panel-mounted, DIN-sized instrument. Signals from either transmitter can also be retransmitted to remote monitoring equipment.

Both models have a single programmable input channel and a single temperature input channel. Instrument operation and programming is via four tactile membrane switches located

on the front panel. Programmed functions are protected from unauthorized alteration by a five-digit security code.

1.3 Principle of Operation– Fig. 1.2

The transmitter unit processes a 4 to 20mA (25% to 0.25% O₂) signal generated at the Interface Electronics Unit and displays the oxygen value in O₂ with selectable ranges (log or linear). All ranges can be retransmitted.

In addition, the transmitter processes any alarm signals generated from the Interface Electronics Unit – see the *EXFG Probe Guide* and *EXFG Interface Electronics Unit Guide* for additional system operating information.

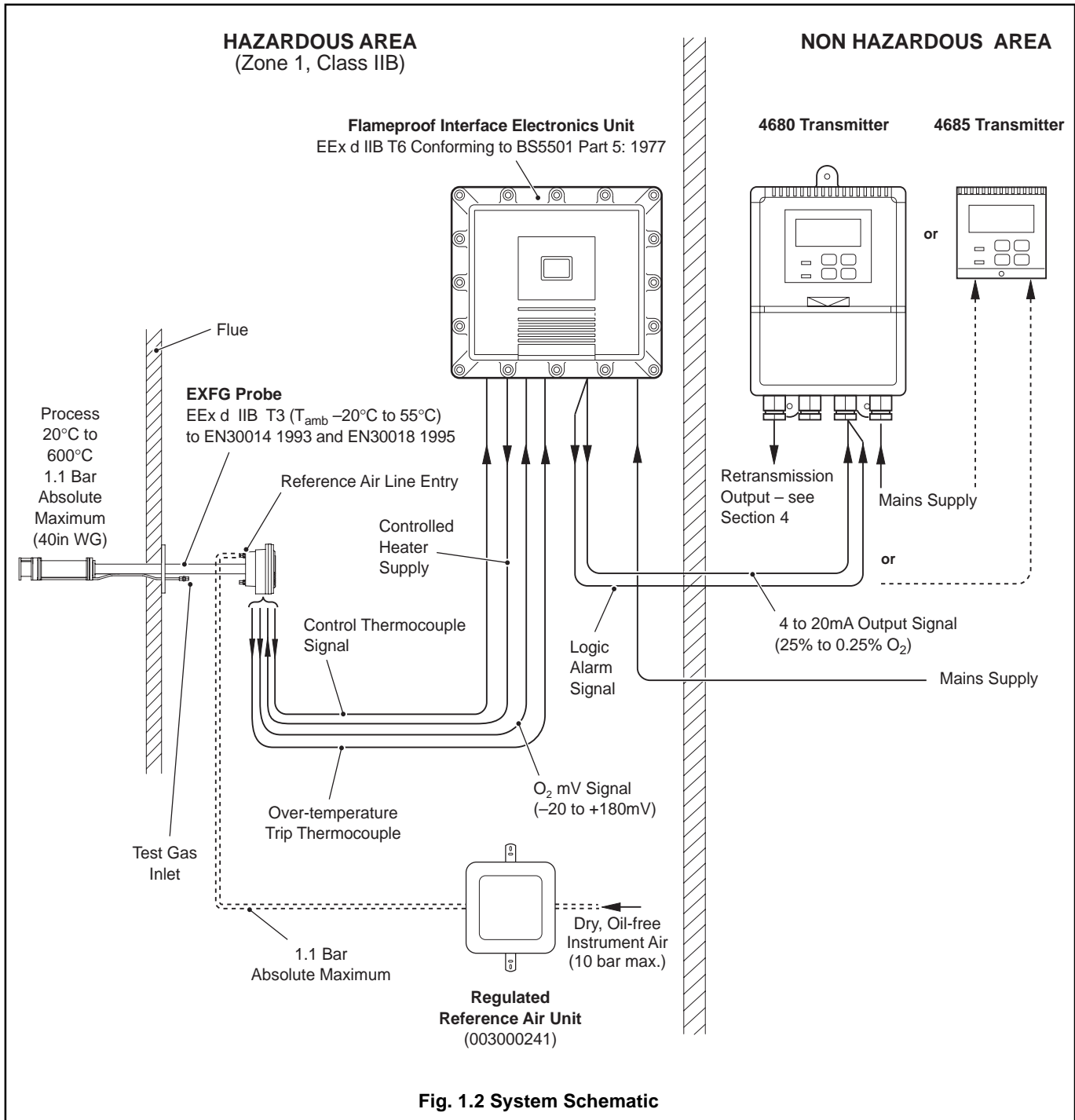

2 PREPARATION

2.1 Checking the Instrument Type

2.1.1 Wall-mounted Instruments – Fig. 2.1

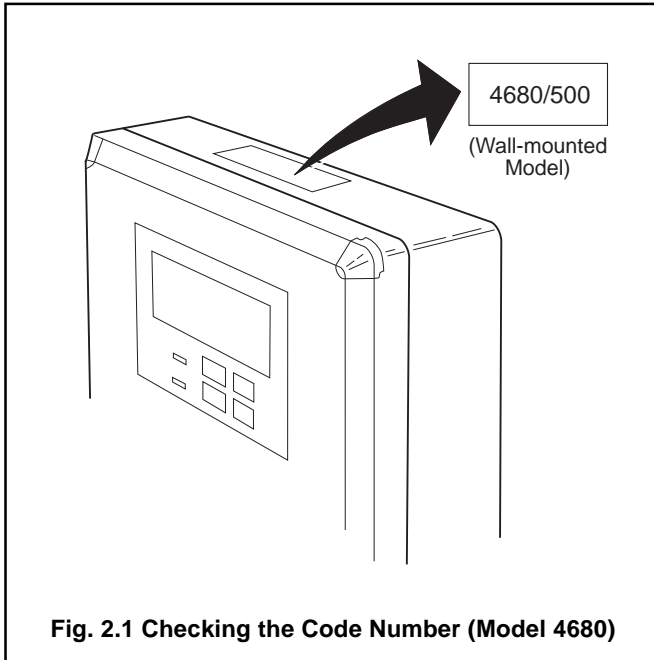

2.1.2 Panel-mounted Instruments – Fig. 2.2

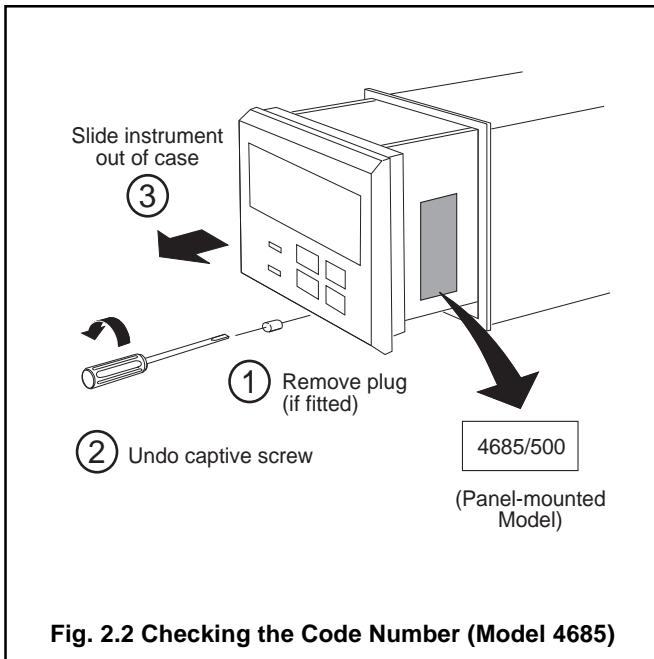

3 MECHANICAL INSTALLATION

3.1 Siting Requirements – Fig. 3.1



Caution.

- Mount in a location free from excessive vibration.
- Mount away from harmful vapors and/or dripping fluids.



Information. It is preferable to mount the instrument at eye level, allowing an unrestricted view of the front panel displays and controls.

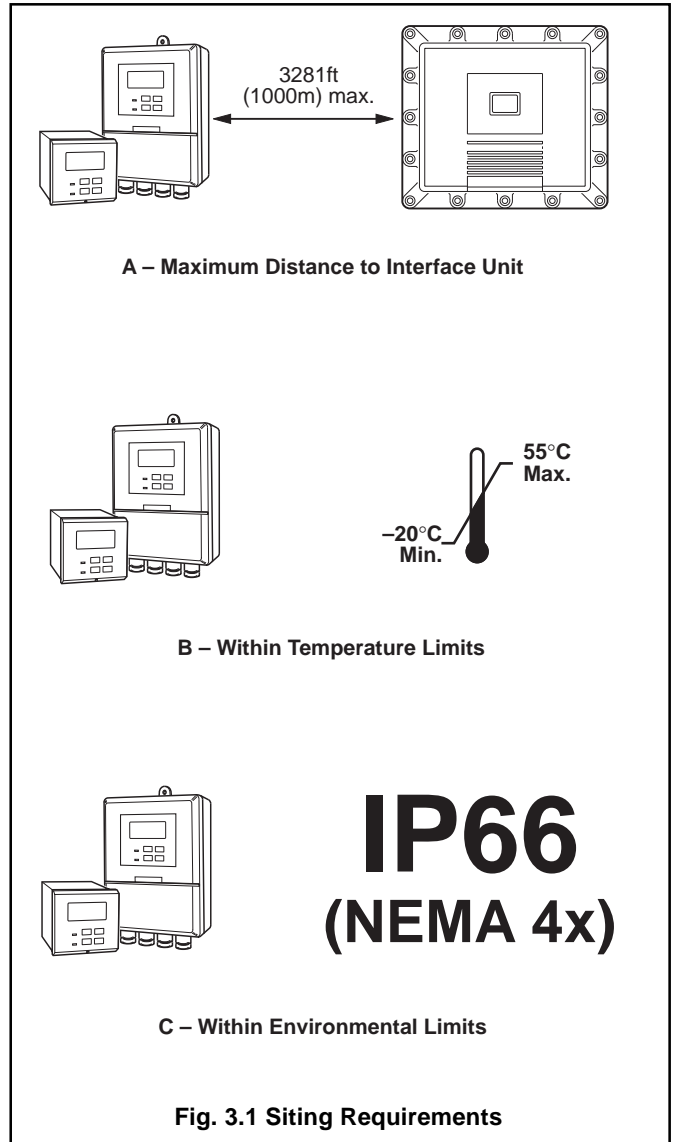

...3 MECHANICAL INSTALLATION

3.2 Mounting

3.2.1 Wall/Pipe-mounted Instruments – Figs. 3.2 and 3.3

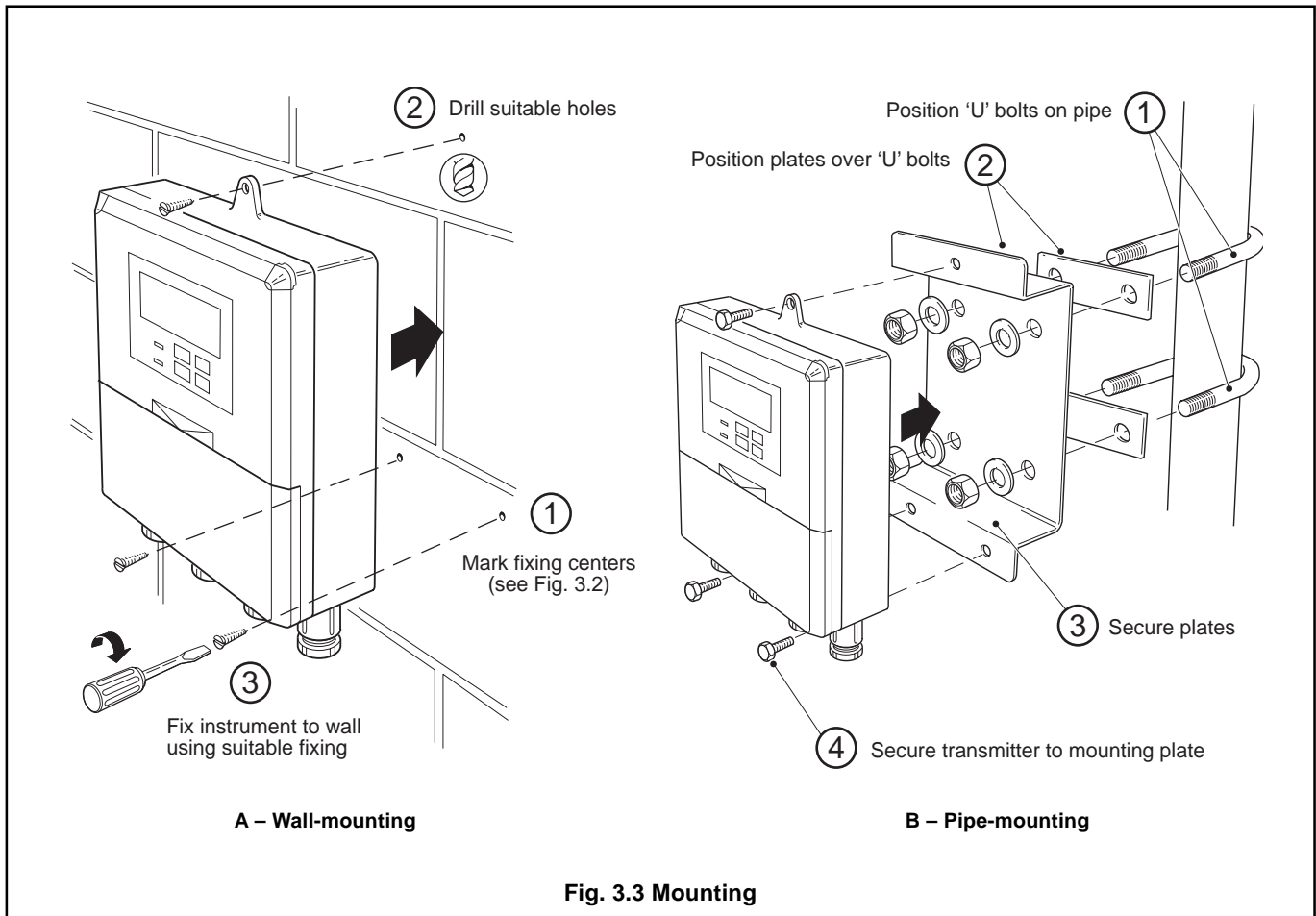
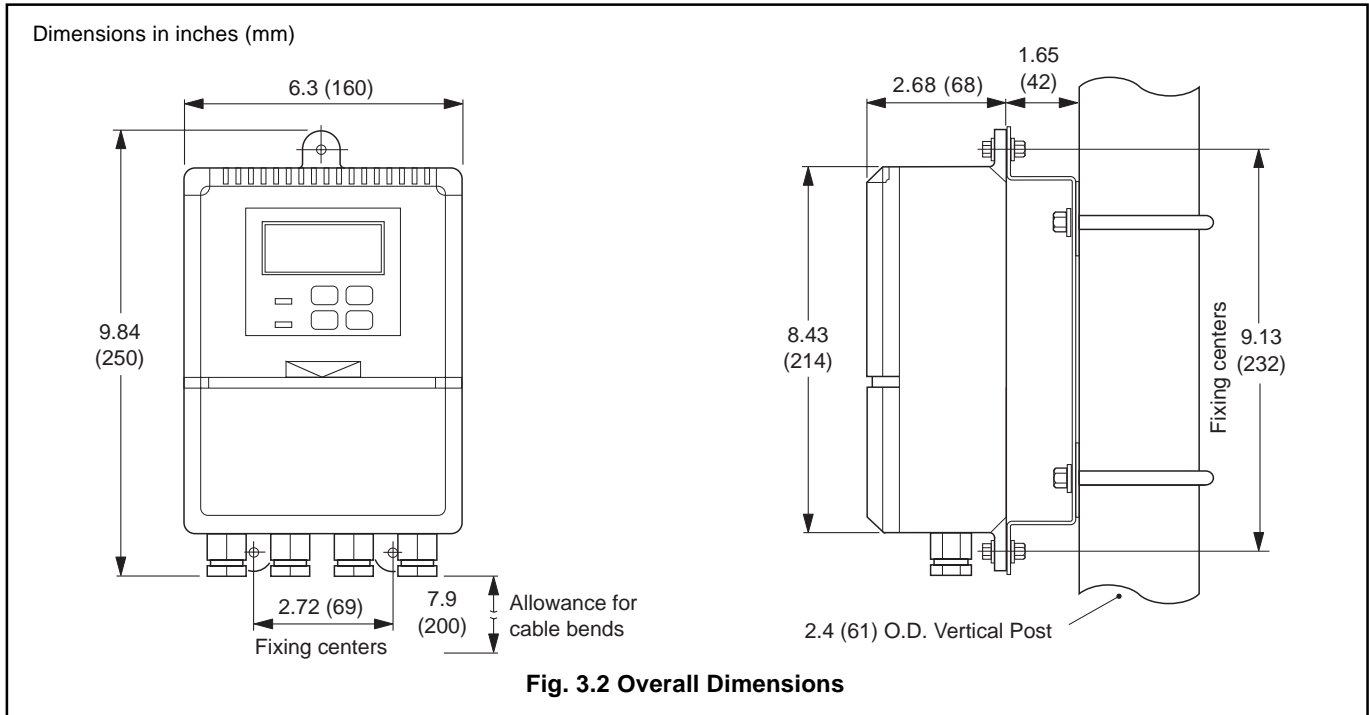

...3.2 Mounting

3.2.2 Panel-mounted Instruments – Figs. 3.4 and 3.5

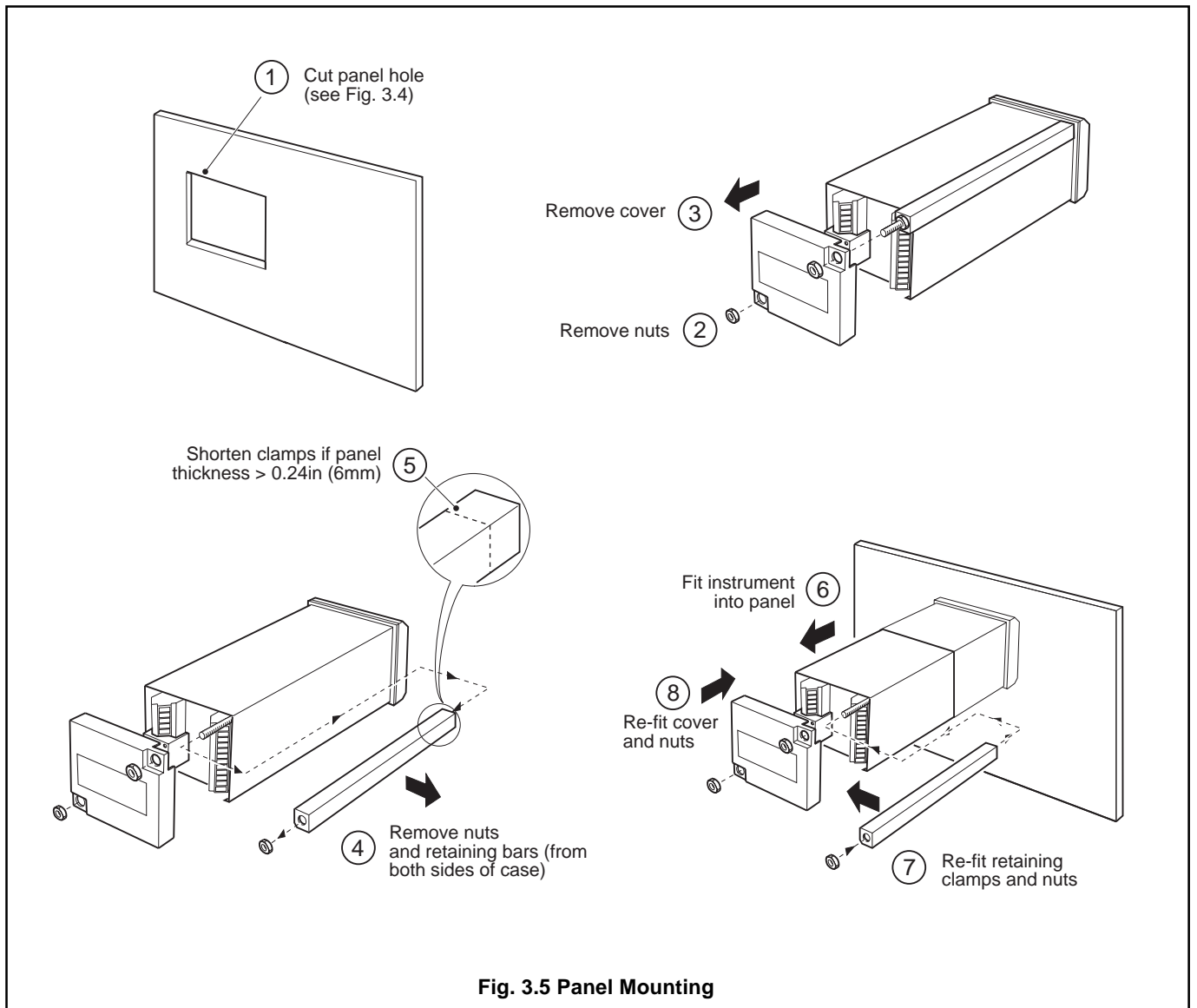
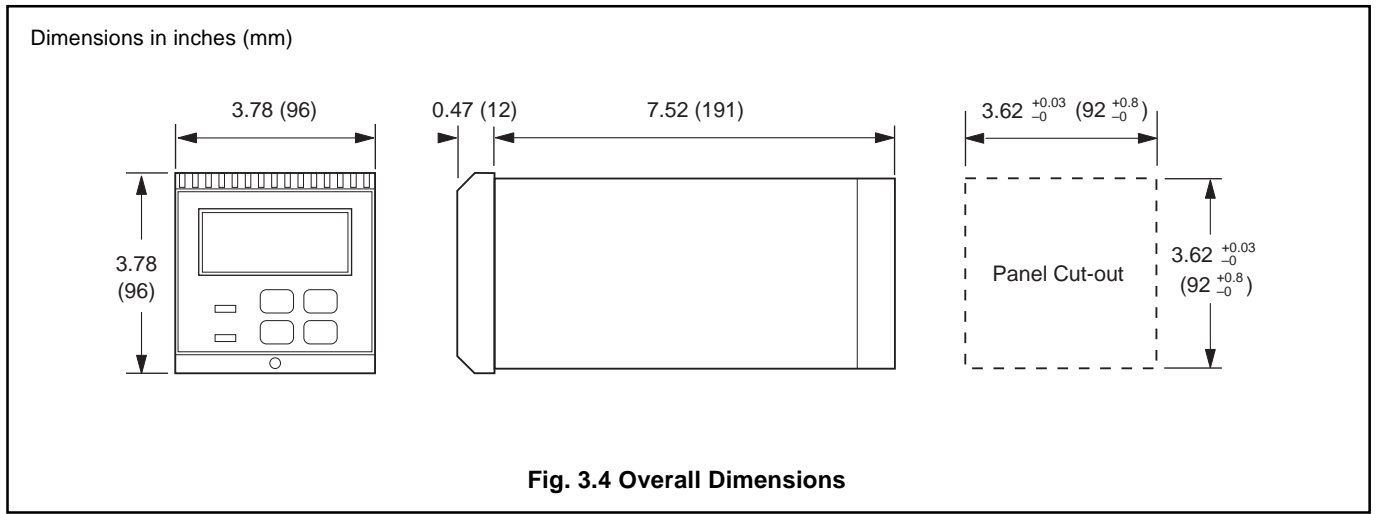

4 ELECTRICAL CONNECTIONS

4.1 Connections – General



Warning.

- **Mains power** – before making any connections, ensure that the power supply, any high voltage-operated control circuits and high common mode voltages are switched off.



Information.

- **Earthing (grounding)** – stud terminal(s) is fitted to the transmitter case for bus-bar earth (ground) connection – see Fig. 4.2 or 4.5.
- **Cable routing** – always route signal output cable leads and mains-carrying/relay cables separately, ideally in earthed metal conduit. Twist the signal output leads together or use screened cable with the screen connected to the case earth stud.

Ensure that the cables enter the transmitter through the glands nearest the appropriate screw terminals and are short and direct. Do not tuck excess cable into the terminal compartment.

- **Cable glands & conduit fittings** – ensure a moisture-tight fit when using cable glands, conduit fittings and blanking plugs/bungs (M20 holes).
- **Relays** – the relay contacts are voltage-free and must be appropriately connected in series with the power supply and the alarm/control device which they are to actuate. Ensure that the contact rating is not exceeded. Refer also to Section 4.1.2 for relay contact protection details when the relays are to be used for switching loads.
- **Retransmission output** – Do not exceed the maximum load specification for the selected current retransmission range (see the associated Specification sheet).

Because the retransmission output is isolated the –ve terminal **must** be connected to earth (ground) if connecting to the isolated input of another device.

4.1.1 Cable and Gland Specifications



Caution.

- **Cabling** – connections between the Transmitter and the Interface Electronics Unit must be in accordance with BS5345 pt3 – Installation and Maintenance Requirements for Electrical Apparatus with type 'd' Protection Flameproof Enclosure.
- **Glands** – EEx d glands used on the Interface Electronics Unit must be of the EEx d 'Barrier Gland' type with BASEEFA certification because the enclosure is over 2 liters volume, has a source of ignition within and is designed for use in Zone 1 areas (reference BS5345 part 3).



Information.

- The M20 glands ready-fitted to wall-mounted instruments accept cable of between 4 and 7mm diameter.
- A spare set of grommets is supplied for cable sizes between 8 and 12mm diameter.

Gland Specification		Cable Specifications	Gland Specification	
M20 BASEEFA certified EEx d barrier gland (not supplied)	Signal cable (not supplied)	16/0.2, 4-core copper, overall screened, flameproof (two pairs) Max. loop resistance 750Ω	4680 M20 Uncertified (fitted)	4685 No gland required
M20 BASEEFA certified EEx d barrier gland (not supplied)	Mains power cable (not supplied)	3-core, 0.5mm ² copper (min.)	4680 M20 Uncertified (fitted)	4685 No gland required

Table 4.1 Cable and Gland Specifications (electrical requirements only)

4.1.2 Relay Contact Protection and Interference Suppression – Fig. 4.1

If the relays are used to switch loads on and off, the relay contacts can become eroded due to arcing. Arcing also generates radio frequency interference (RFI) which can result in instrument malfunctions and incorrect readings. To minimize the effects of RFI, arc suppression components are required; resistor/capacitor networks for a.c. applications or diodes for d.c. applications. These components can be connected either across the load or directly across the relay contacts. On 4600 Series instruments the RFI components must be fitted to the relay terminal block along with the supply and load wires – see Fig 4.1

For **a.c. applications** the value of the resistor/capacitor network depends on the load current and inductance that is switched. Initially, fit a 100R/0.022µF RC suppressor unit (part no. B9303) as shown in Fig. 4.1A. If the instrument malfunctions (incorrect readings) or resets (display shows 88888) the value of the RC network is too low for suppression an alternative value must be used. If the correct value cannot be obtained, contact the manufacturer of the switched device for details on the RC unit required.

For **d.c. applications** fit a diode as shown in Fig. 4.1B. For general applications use a 1N5406 type (600V peak inverse voltage at 3A – part no. B7363).

Note. For reliable switching the minimum voltage must be greater than 12V and the minimum current greater than 100mA

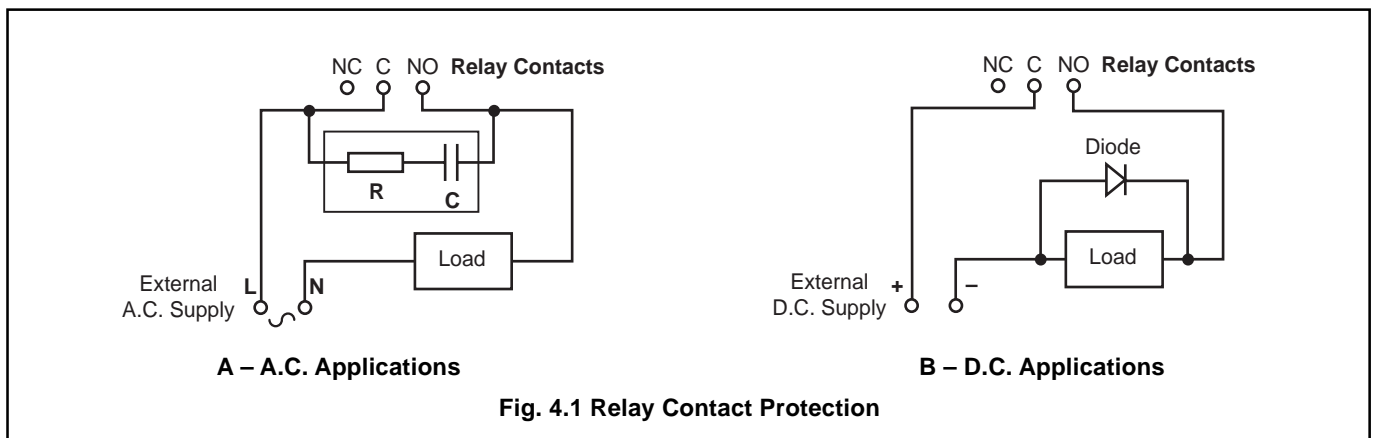

...4 ELECTRICAL CONNECTIONS

4.2 Wall-mounted Instrument Connections – Figs. 4.2 and 4.3



Caution. Slacken terminal screws fully before making connections.

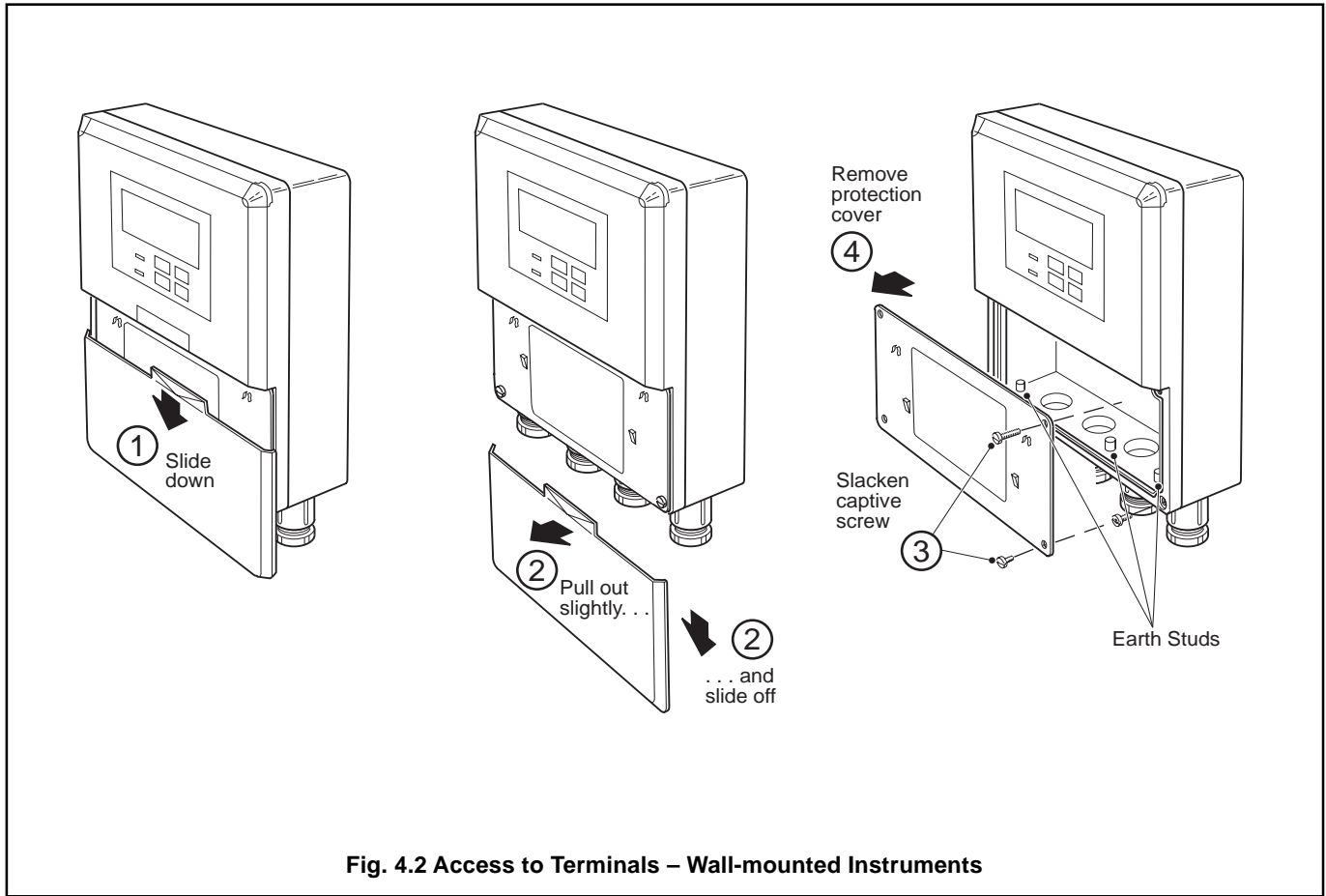

...4.2 Wall-mounted Instrument Connections – Figs. 4.2 and 4.3

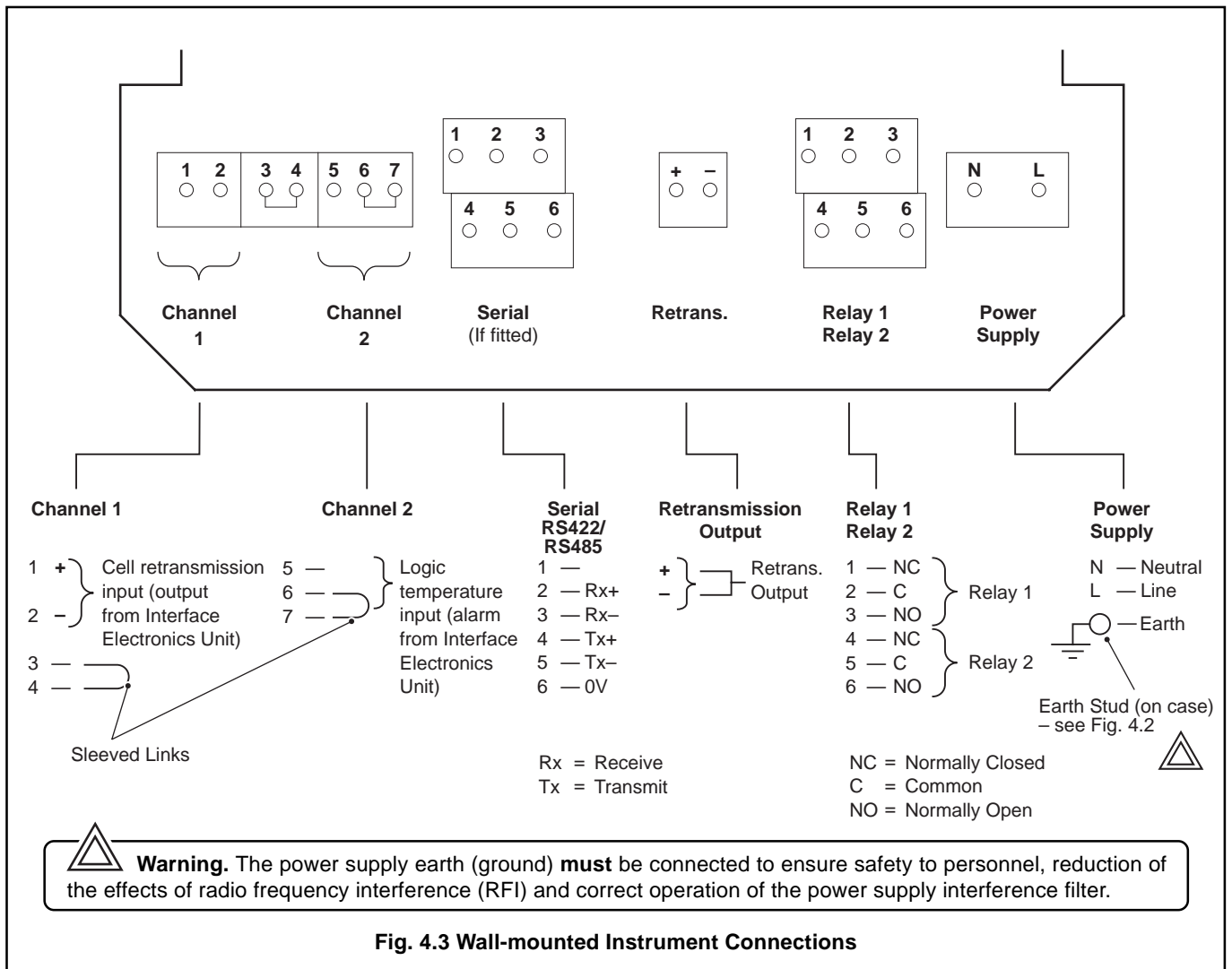

...4 ELECTRICAL CONNECTIONS

4.3 Panel-mounted Instrument Connections – Figs. 4.4 and 4.5



Caution. Slacken terminal screws fully before making connections.

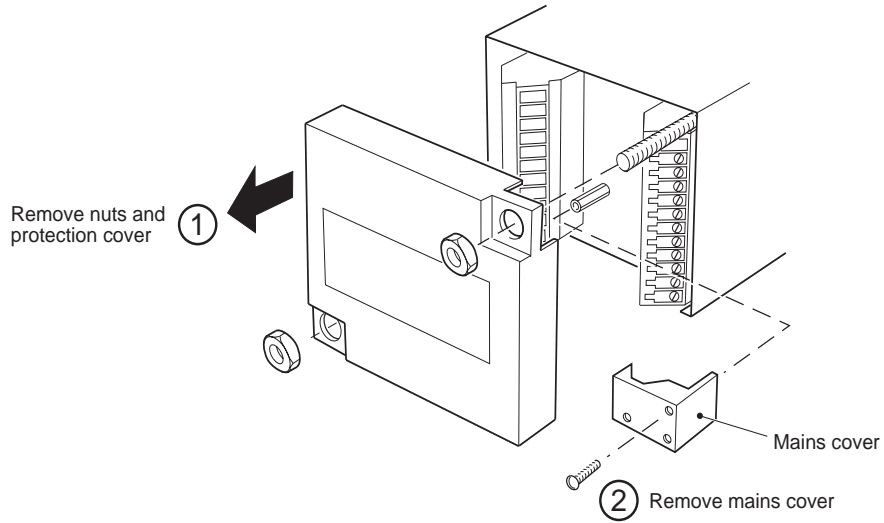
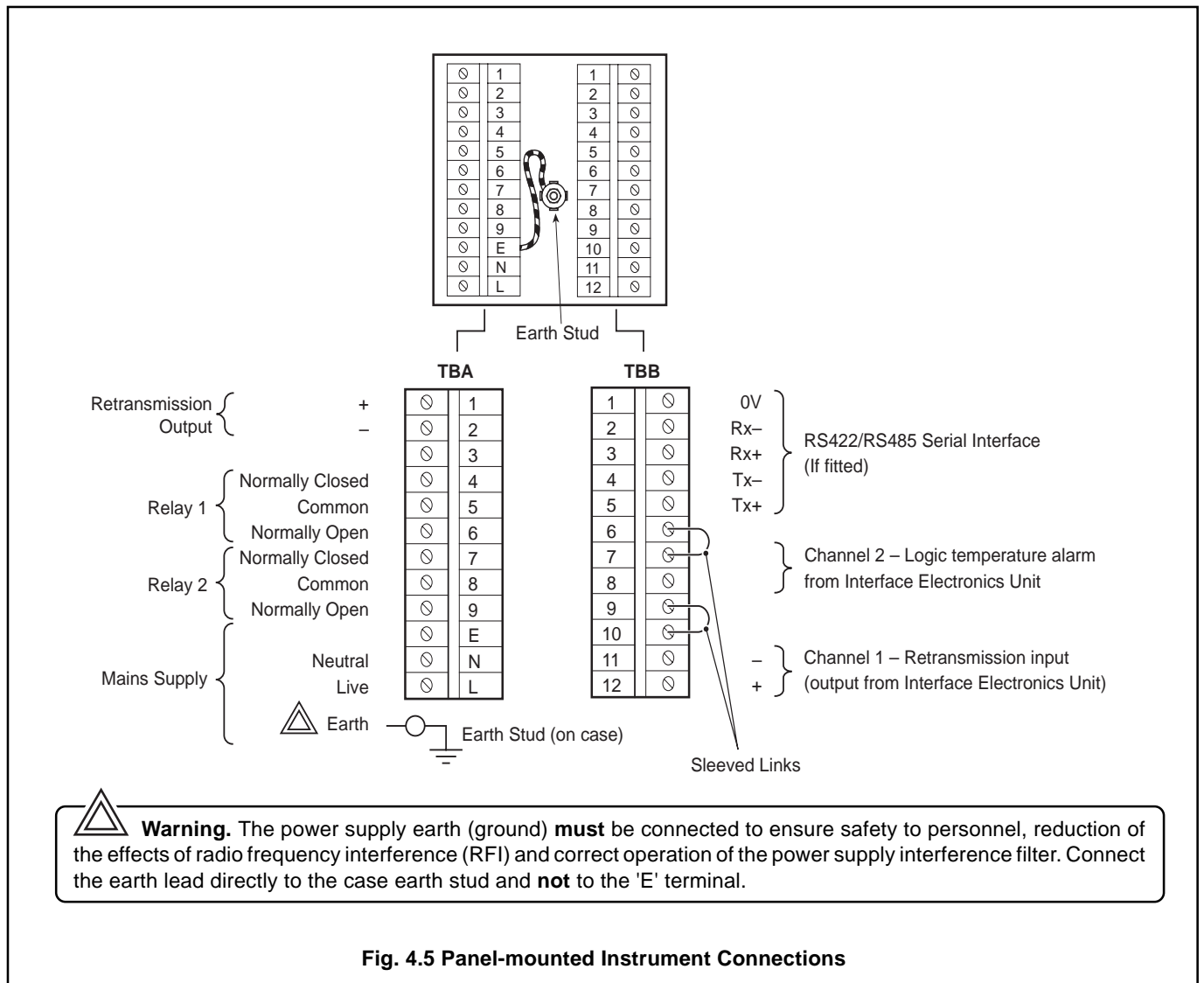

Fig. 4.4 Access to Terminals – Panel-mounted Instruments

...4.3 Panel-mounted Instrument Connections – Figs. 4.4 and 4.5



Warning. The power supply earth (ground) **must** be connected to ensure safety to personnel, reduction of the effects of radio frequency interference (RFI) and correct operation of the power supply interference filter. Connect the earth lead directly to the case earth stud and **not** to the 'E' terminal.

Fig. 4.5 Panel-mounted Instrument Connections

...4 ELECTRICAL CONNECTIONS

4.4 Selecting the Mains Voltage

4.4.1 Wall/Pipe-mounted Instruments – Fig. 4.6

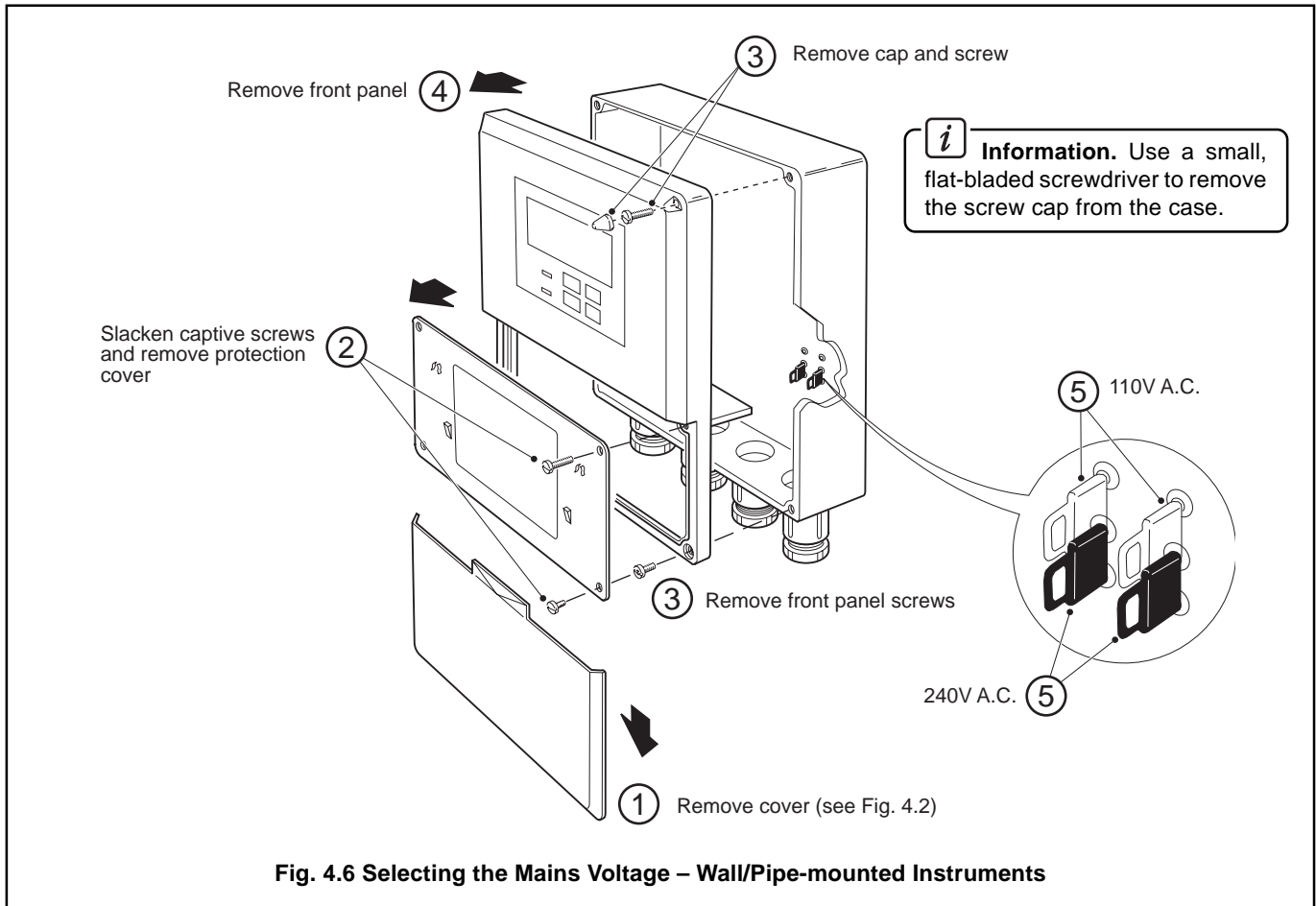

Fig. 4.6 Selecting the Mains Voltage – Wall/Pipe-mounted Instruments

4.4.2 Panel-mounted Instruments – Fig. 4.7

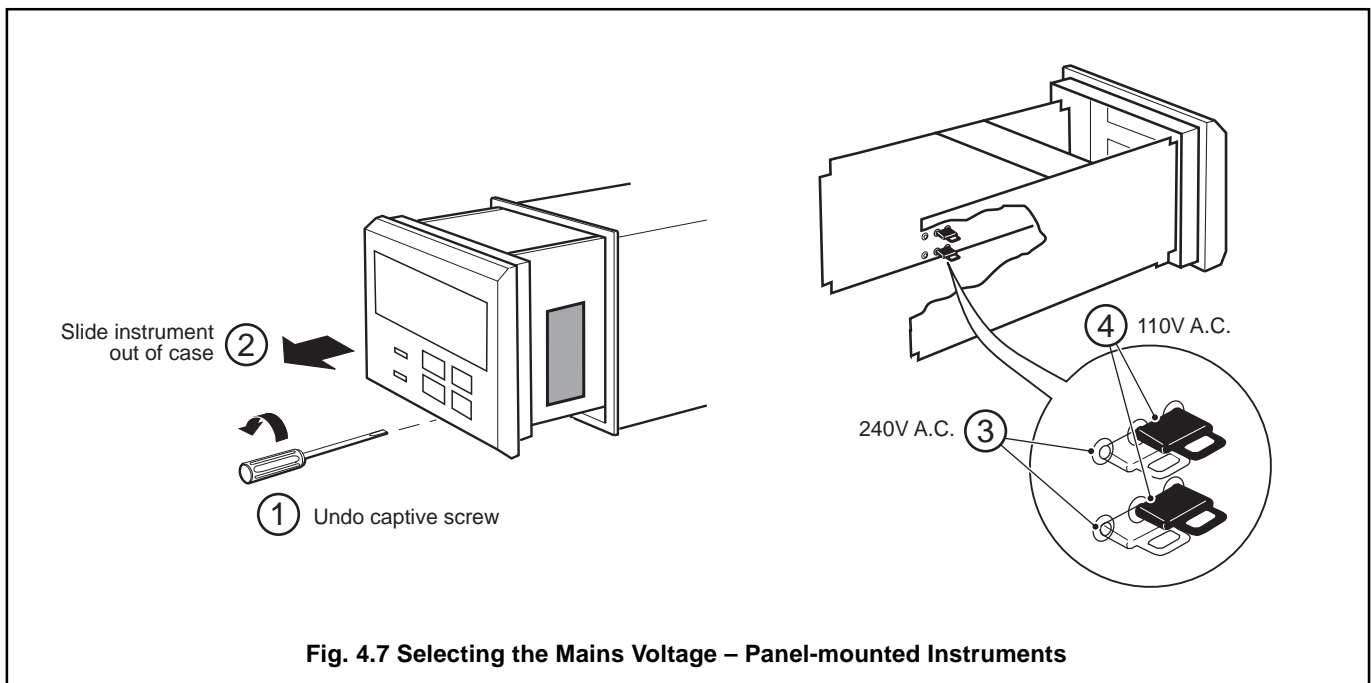
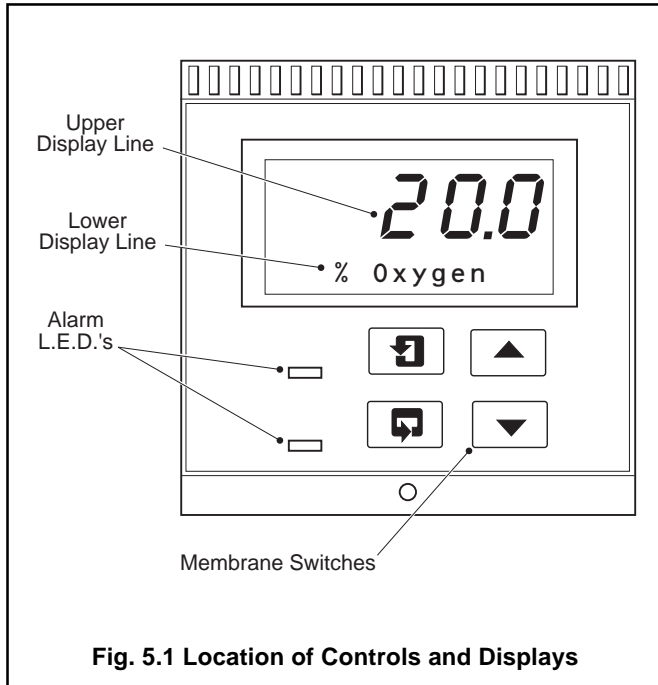

Fig. 4.7 Selecting the Mains Voltage – Panel-mounted Instruments

5.1 Displays – Fig. 5.1

The display comprises a 5-digit, 7-segment digital upper display line and a 16-character dot-matrix lower display line. The upper display line shows actual values of oxygen, alarm set points or programmable parameters. The lower display line shows the associated units or programming information.



5.2 Switch Familiarization

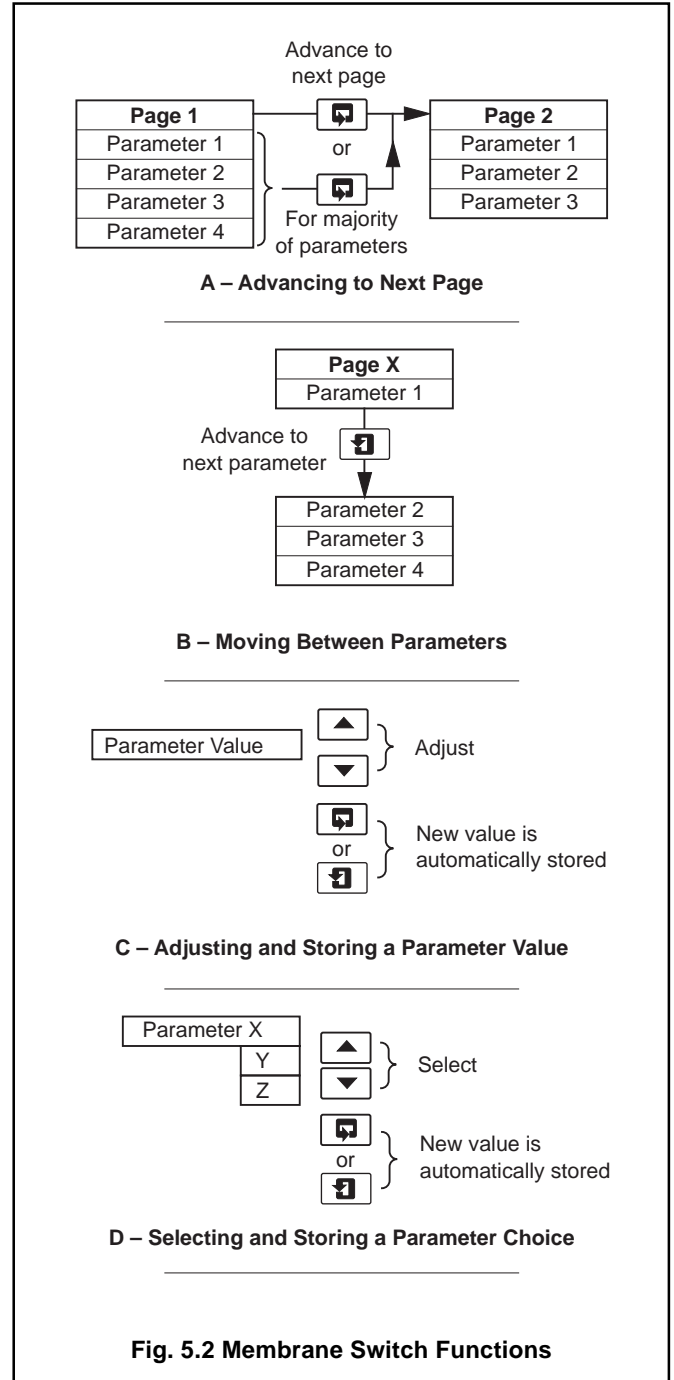

6 OPERATION

6.1 Instrument Start-up

Ensure all electrical connections have been made correctly and switch on.

6.2 Operating Page

The **Operating Page** is a general use page in which parameters are viewed only and cannot be altered. To alter or program a parameter refer to the programming pages in Section 7.

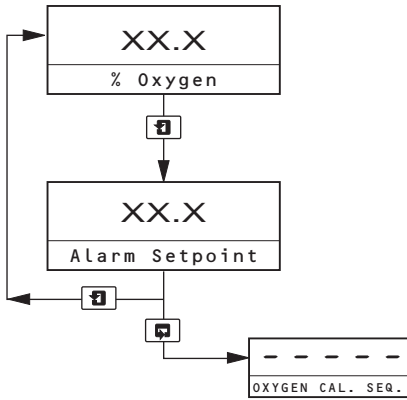

% Oxygen

The upper display indicated the measured oxygen value. If over or under temperature is monitored, the upper display shows '- - - -' and an error message is displayed on the lower dot matrix display – see Table 6.1.

Alarm Set Point

The upper display indicates the alarm set point, displayed as % oxygen. The set point value and the relay/l.e.d. action can be programmed in the **Set Up Outputs Page** – see Section 7.2.

Advance to **Oxygen Calibration Sequence** page.



Note. Electrical calibration is carried out prior to despatch and should not be altered. However, if inaccurate or inconsistent readings are obtained, refer to the *Electrical Calibration Supplement* for full calibration procedures.

6.2.1 Operating Page Error Messages

The following error messages only appear in the **Operating Page** (when an error has been detected), in place of the % oxygen frame.



Note. Relay 2 is assigned as a malfunction alarm and de-energizes when an error condition is present. The l.e.d. assigned to this relay is illuminated when in an error condition.

Error Message	Possible Cause
NV MEMORY ERROR	The contents of the non-volatile memory have not been read correctly during power up. To rectify the fault, switch off, wait 10 seconds and switch on again. If the fault persists contact the Manufacturer.
CELL UNDER TEMP.	The temperature at the probe sensor has not reached a sufficient temperature to obtain suitable readings (less than 670°C at the control thermocouple).
OVER TEMP. TRIP	The temperature at the probe sensor has exceeded the maximum permissible temperature (greater than 750°C) and has now switched the power to the heater off. Refer to <i>EXFG Interface Electronics Unit Guide</i> and <i>EXFG Probe Guide</i> .
OUT OF LIMITS	The Interface Electronics Unit is switched off or mains power to the Interface Electronics Unit has failed. The measured % oxygen value is outside the limits of the instrument. (The upper display flashes if outside the limits of 0.25% to 25%).

Table 6.1 Error Messages

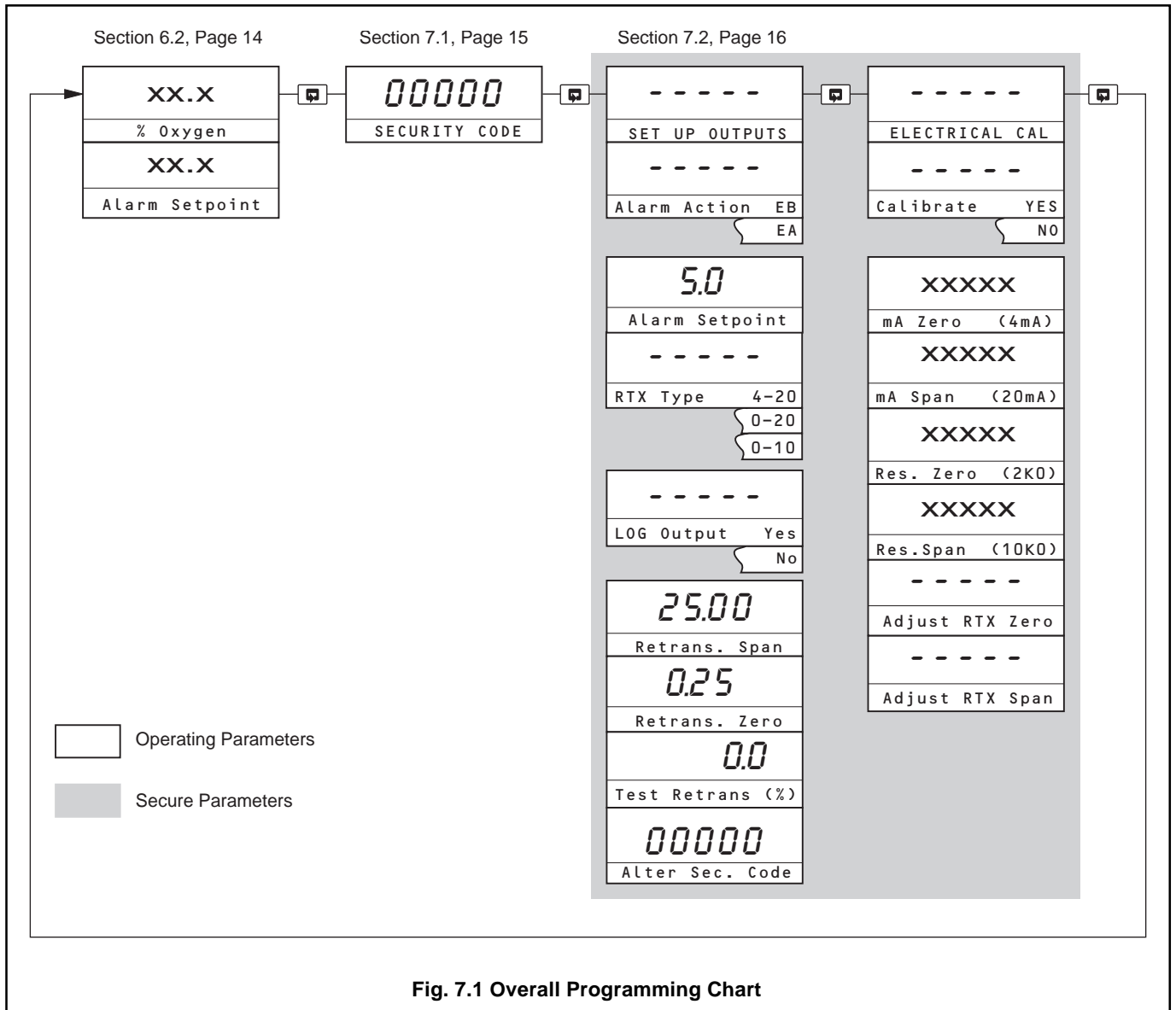
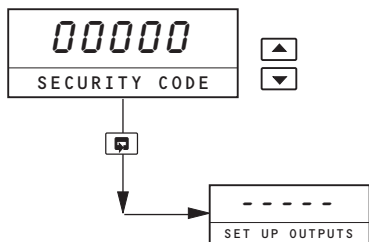

Fig. 7.1 Overall Programming Chart

7.1 Access to Secure Parameters



Security Code

Enter the required code number, between 00000 and 19999, to gain access to the secure parameters. If an incorrect value is entered, subsequent programming pages cannot be accessed.

Advance to **Set Up Outputs** page.

...7 PROGRAMMING

7.2 Set Up Outputs Page

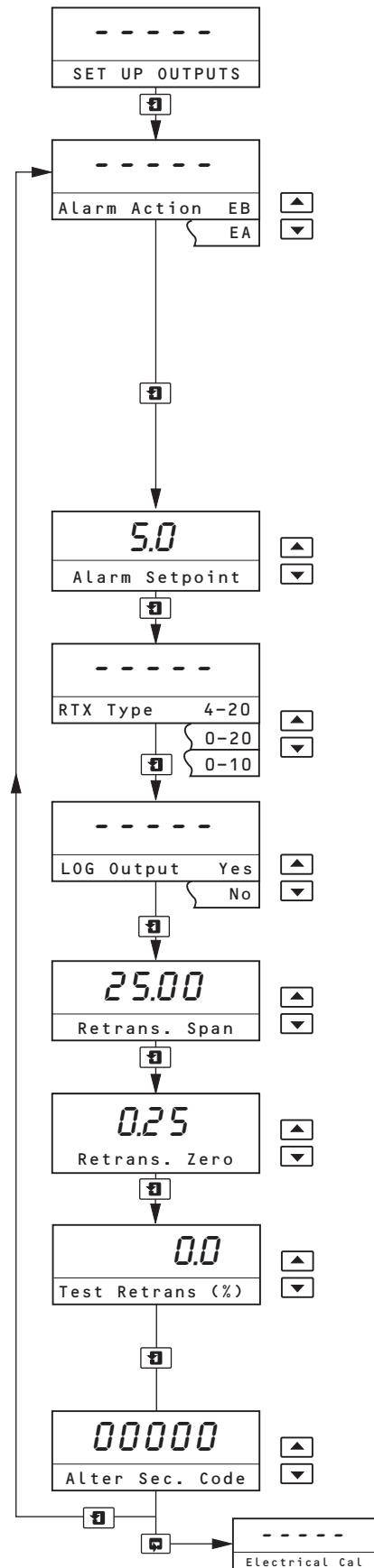

Set Up Outputs

Page header

Alarm Action

Set the required alarm action from the following table.

Alarm Action	LED Action for input Above Set Point	LED Action for input Below Set Point	LED Action for input Above Set Point	LED Action for input Above Set Point
EA	ON	OFF	OFF	ON
EA	OFF	ON	ON	OFF

The set point band is defined as the actual value of the set point plus or minus the hysteresis value. The hysteresis value is fixed at 0.1% oxygen. Alarm action occurs if the input value is above or below the set point band. If the input moves within the set point band the last alarm action is maintained.

Alarm Set Point

The alarm set point can be set to any value within the oxygen range of 0.3% to 25.0%.

Retransmission Type

The retransmission output is assigned to the oxygen range.

Select the retransmission output current range required (4 to 20mA, 0 to 20mA or 0 to 10mA).

LOG Output

The retransmission can be assigned to give a logarithmic or linear output.

Select YES for Logarithmic, NO for Linear.

Retransmission Span

Select the required retransmission span value, in % oxygen units, from 5.25% to 25.00%.

Retransmission Zero

Select the required retransmission zero value, in % oxygen units, from 0.25% to 20.00%.

Test Retransmission

The instrument automatically transmits a test signal of 0, 25, 50, 75 and 100% of the retransmission range selected above. The % test signal selected is shown on the upper display.

Example: for a selected range of 0 to 20mA and 50% retransmission test signal, 10mA is transmitted.

Alter Security Code

Set the security code to a value between 00000 and 199999.

Advance to **Electrical Calibration** page.



Note. Electrical calibration is carried out prior to despatch and should not be altered. However, if inaccurate or inconsistent readings are obtained, refer to the *Electrical Calibration Supplement* for full calibration procedures.

CUSTOMER SUPPORT

Service, Support and Maintenance

ABB Process Analytics' commitment to quality doesn't end when we deliver our equipment.

We also provide, at the client's request: start-up services, maintenance services, training services, reconditioning, repair and replacement parts services.

Training services are available for virtually every aspect of operating and maintaining ABB Process Analytics analyzers and systems. Training may be arranged on-site or at any of our training centres.

Maintenance services are available on an unscheduled, as needed basis, or by way of long-term, scheduled maintenance agreements.

Facilities

ABB Process Analytics' primary manufacturing and administrative facility is located in Lewisburg, West Virginia. We also operate sales and service centres in Houston, Texas; Baton Rouge, Louisiana; Sarnia, Ontario; UK; France; Italy; The Netherlands and Singapore. Training centres are located in Lewisburg, Houston and Europe.

For complete information and assistance with ABB Process Analytics analyzers, systems and services, contact any of our facilities for details of your nearest Service and Repair Centre.

United States

ABB Process Analytics
843 N. Jefferson Street
Lewisburg, WV 24901
USA
Office: (304)647-4358
FAX: (304)645-4236

United Kingdom

ABB Process Analytics Ltd
Howard Road
Eaton Socon, St. Neots
Cambs. UK PE19 3EU
Office: 44-1480-404440
FAX: 44-1480-405775

Benelux

ABB Process Analytics BV
Pampuslaan 89
1382 JM Weesp
Netherlands
Office: 31-2944-17291
FAX: 31-2944-13656

Pacific Rim

ABB Industry Pte. Ltd.
No. 2 Ayer Rajah Crescent
Singapore 0513
Office: 65-776-5711
FAX: 65-778-0222

Canada

ABB Process Analytics
1362 Lambton Mall Road
Unit#18
Sarnia, Ontario N7S 5R6
CANADA
Office: (519)541-0011
FAX: (519)541-0012

Middle East

ABB ARESCON
PO Box 2774
Manama, Bahrain
Office: 973-725377
FAX: 973-725332

France

ABB Instrumentation
Process Analytics Div
6/8 Rue Peupliers
BP 430-92004 Nanterre
Cedex, France
Office: 33-1-4769-7280
FAX: 33-1-4242-3995

Italy

ABB Kent-Taylor SpA
Process Analytics Division
Valle Edison, 50
20099 Sesto S. Giovanni - MI
Italy
Office: 39-2-262321
FAX: 39-2-26232902



The Company's policy is one of continuous product improvement and the right is reserved to modify the information contained herein without notice.

© February 1996 ABB Process Analytics Printed in U.K.

ABB Process Analytics
843 N. Jefferson Street
Lewisburg, WV 24901
USA
Office: (304)647-4358
FAX: (304)645-4236