

Obsolete product!
Please see JSTD25 for replacement.



Original instructions

JSTD20

Two-hand device



Read and understand this document

Please read and understand this document before using the products. Please consult your ABB JOKAB SAFETY representative if you have any questions or comments.

WARRANTY

ABB JOKAB SAFETY's exclusive warranty is that the products are free from defects in materials and workmanship for a period of one year (or other period if specified) from date of sale by ABB JOKAB SAFETY.

ABB JOKAB SAFETY MAKES NO WARRANTY OR REPRESENTATION, EXPRESSED OR IMPLIED, REGARDING NON-INFRINGEMENT, MERCHANTABILITY, OR FITNESS FOR PARTICULAR PURPOSE OF THE PRODUCTS, ANY BUYER OR USER ACKNOWLEDGES THAT THE BUYER OR USER ALONE HAS DETERMINED THAT THE PRODUCTS WILL SUITABLY MEET THE REQUIREMENTS OR THEIR INTENDED USE. ABB JOKAB SAFETY DISCLAIMS ALL OTHER WARRANTIES, EXPRESSED OR IMPLIED.

LIMITATIONS OF LIABILITY

ABB JOKAB SAFETY SHALL NOT BE RESPONSIBLE FOR SPECIAL, INDIRECT, OR CONSEQUENTIAL DAMAGES, LOSS OF PROFITS OR COMMERCIAL LOSS IN ANY WAY CONNECTED WITH THE PRODUCTS, WHETHER SUCH CLAIM IS BASED ON CONTRACT, WARRANTY, NEGLIGENCE, OR STRICT LIABILITY.

In no event shall responsibility of ABB JOKAB SAFETY for any act exceed the individual price of the product on which liability asserted.

IN NO EVENT SHALL ABB JOKAB SAFETY BE RESPONSIBLE FOR WARRANTY, REPAIR, OR OTHER CLAIMS REGARDING THE PRODUCTS UNLESS ABB JOKAB SAFETY'S ANALYSIS CONFIRMS THAT THE PRODUCTS WERE PROPERLY HANDLED, STORED, INSTALLED, AND MAINTAINED AND NOT SUBJECT TO ABUSE, MISUSE, OR INAPPROPRIATE MODIFICATION OR REPAIR.

SUITABILITY FOR USE

ABB JOKAB SAFETY shall not be responsible for conformity with any standards, codes, or regulations that apply to the combination of products in the customer's application or use of the product. At the customer's request, ABB JOKAB SAFETY will provide applicable third party certification documents identifying ratings and limitations of use that apply to the products. This information by itself is not sufficient for a complete determination of the suitability of the products in combination with the end product, machine, system, or other application or use.

The following are some examples of applications for which particular attention must be given. This is not intended to be an exhaustive list of all possible uses of the products, nor is it intended to imply that the uses listed may be suitable for the products:

Outdoor use, uses involving potential chemical contamination or electrical interference, or conditions or uses not described in this document.

Nuclear energy control systems, combustion systems, railroad systems, aviation systems, medical equipment, amusement machines, vehicles, and installations subject to separate industry or government regulations.

Systems, machines, and equipment that could present a risk to life or property.

Please know and observe all prohibitions of use applicable to the products.

NEVER USE THE PRODUCTS FOR AN APPLICATION INVOLVING SERIOUS RISK TO LIFE OR PROPERTY WITHOUT ENSURING THAT THE SYSTEM AS A WHOLE HAS BEEN DESIGNED TO ADDRESS THE RISKS, AND THAT THE ABB JOKAB SAFETY PRODUCT IS PROPERLY RATED AND INSTALLED FOR THE INTENDED USE WITHIN THE OVERALL EQUIPMENT OR SYSTEM.

PERFORMANCE DATA

While every effort has been taken to ensure the accuracy of the information contained in this manual ABB JOKAB SAFETY cannot accept responsibility for errors or omissions and reserves the right to make changes and improvements without notice. Performance data given in this document is provided as a guide for the user in determining suitability and does not constitute a warranty. It may represent the result of ABB JOKAB SAFETY'S test conditions, and the users must correlate it to actual application requirements. Actual performance is subject to the ABB JOKAB SAFETY Warranty and Limitations of Liability.

Table of Contents

1	Introduction	4
	Scope	4
	Audience	4
	Prerequisites	4
	Special notes	4
2	Overview	5
	General description.....	5
	Safety regulations	5
	Function description.....	5
3	Connections	6
4	Installation and maintenance	7
	Installation.....	7
	Maintenance	7
	Minimum safety distance	7
5	Application examples	8
6	Model overview	9
	Accessories.....	9
	Dimensions	9
7	Technical data	10
8	EC Declaration of conformity	12

1 Introduction

Scope

The purpose of these instructions is to describe the two-hand device JSTD20 and to provide the necessary information required for assembly, installation, operations, checks and adjustments after installation, and maintenance. The instructions also include information necessary to connect JSTD20 to a safety circuit.

Audience

This document is intended for authorized installation personnel.

Prerequisites

It is assumed that the reader of this document has knowledge of the following:

- Basic knowledge of ABB Jokab Safety products.
- Knowledge of enabling devices.
- Knowledge of machine safety.

Special notes

Pay attention to the following special notes in the document:

 **Warning!** Danger of severe personal injury!
An instruction or procedure which, if not carried out correctly, may result in injury to the technician or other personnel.

Caution! Danger of damage to the equipment!
An instruction or procedure which, if not carried out correctly, may damage the equipment.

NB: Notes are used to provide important or explanatory information.

2 Overview

General description

The JSTD20 two-hand device is intended for use where it is necessary to ensure that the operator's hands will be kept outside the risk area.

The JSTD20 utilises a welded steel housing where two operating pushbuttons are protected by over hand guards. Between the pushbuttons there is space for an emergency pushbutton and two extra controls or indication lamps. The JSTD20 is available with or without an emergency stop pushbutton.

The device can be mounted directly on the machine, on the ABB Jokab Safety fencing system or on the JSTS30 or JSTS31 floor mount.

Safety regulations

Warning!

Carefully read through this entire manual before using the device.

The devices shall be installed by a trained electrician following the Safety regulations, standards and the Machine directive.

Failure to comply with instructions, operation that is not in accordance with the use prescribed in these instructions, improper installation or handling of the device can affect the safety of people and the plant.

For installation and prescribed use of the product, the special notes in the instructions must be carefully observed and the technical standards relevant to the application must be considered.

In case of failure to comply with the instructions or standards, especially when tampering with and/or modifying the product, any liability is excluded.

Function description

To be able to operate the machine with the two-hand device, both the buttons on the device have to be operated within 0.5 seconds of each other. This is called concurrence. Both the buttons also have to be returned to their initial position before one can start again. If any button is released during the machine movement the machine will be stopped. These demands are supervised by a safety relay or similar.

To achieve the highest safety level with a two-hand device it's necessary to have a safety relay or a safety PLC that fulfill the standard EN 574 according to type IIIc.

The JSTD20 is equipped with a type of large over hand guards in accordance with EN 574. These prevent unintended activation by for instance a knee or elbow.

3 Connections

Each of the operating pushbuttons has one normally open and one normally closed contact. As an option an Emergency stop can be added to the JSTD20. Then there are two more NC-contacts to connect.

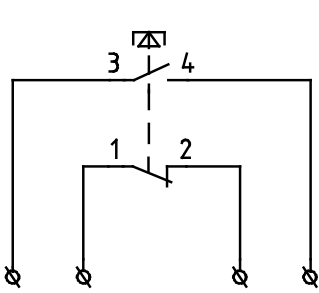

Left button

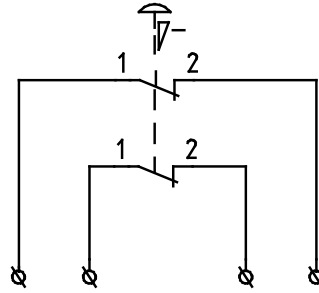

Emergency stop

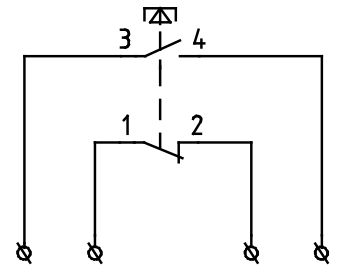

Right button

4 Installation and maintenance

Installation

1. The installation of the two-hand device must be in accordance with a risk assessment for the individual application. Installation must only be carried out by competent personnel and in accordance with these instructions.
2. Make electrical connections according to the connection diagram. Maximum conductor size is 2.5 mm². Maximum torque is 1.0 Nm.
3. To ensure IP seal, use correct size cable gland and make sure the bottom lid with gasket is firmly attached. Use 4.0 Nm torque for the 8 M5 screws in the lid.
4. Use 4 M10 screws (torque 30-60 Nm depending on quality of screws and nuts) to fasten the station to a stand or another robust structure.

 **Warning!** All the safety functions must be tested before starting up the system.

Maintenance

Daily checks: The function of the two-hand control system should be checked daily. Check that the safety relay is de-energized and the machine is stopped when one or both of the JSTD20 pushbuttons are released. Check that the pushbuttons have a distinct operating function.

 **Warning!** The safety functions and the mechanics shall be tested regularly, at least once every year to confirm that all the safety functions are working properly.

 **Warning!** In case of breakdown or damage to the product, contact the nearest ABB Jokab Safety Service Office or reseller. Do not try to repair the product yourself since it may accidentally cause permanent damage to the product, impairing the safety of the device which in turn could lead to serious injury to personnel.

Caution! ABB Jokab Safety will not accept responsibility for failure of the switch functions if the installation and maintenance requirements shown in this sheet are not implemented. These requirements form part of the product warranty.

Minimum safety distance

When using a two-hand device the minimum allowed safety distance between the enabling device and the hazardous machine must be calculated. In order to ensure that the hazardous machine motion will be stopped before it can be reached, the minimum safety distance is calculated according to EN ISO 13855 ("Positioning of safeguards with respect to the approach speeds of parts of the human body").

The minimum safety distance is calculated according to the formula:

$$S = (K \times T) + C$$

Where

S = minimum safety distance (mm)

K = approach speed of a hand; 1600 mm/s

T = total stopping time for the dangerous movement, including the relay response time in seconds

C = constant for possible encroachment while the actuators are operated.

C=0 mm due to the large over hand guards

 **Warning!** The minimum mounting distance must never be less than 100 mm.

5 Application examples

Application example

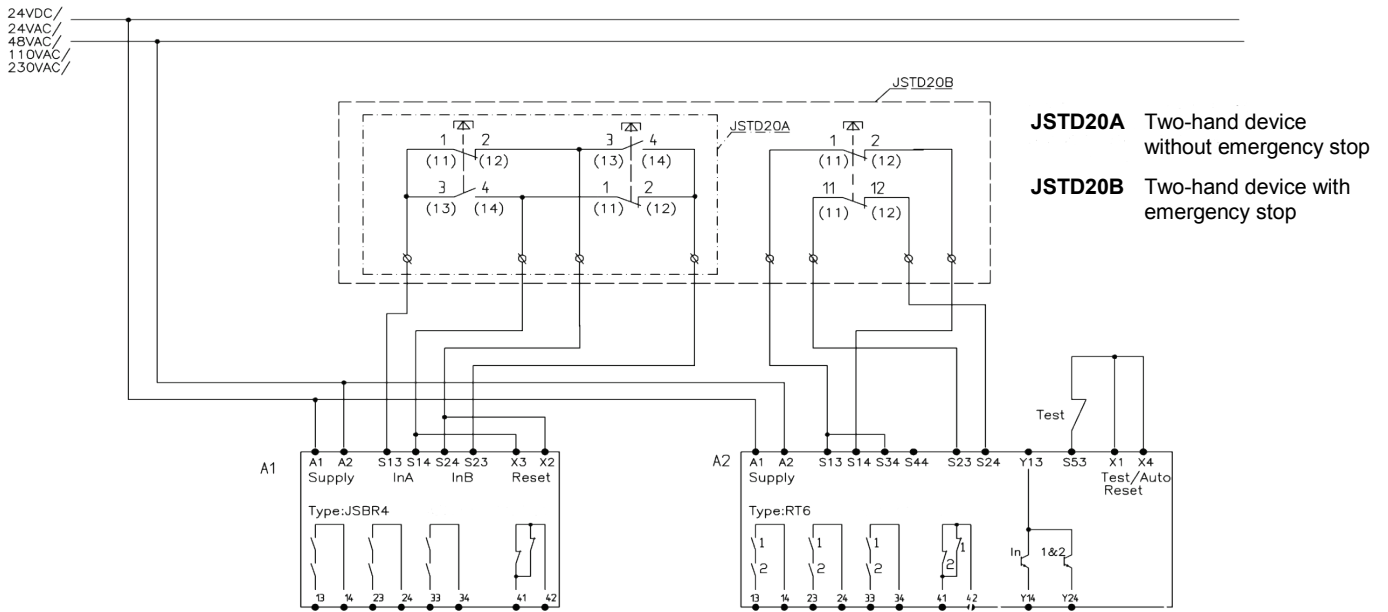

Two-hand device, JSTD20A or JSTD20B connected to JSBR4 safety relay and RT6 safety relay (JSTD20B). JSBR4 manages the two-hand control and RT6 managing the Emergency stop.

6 Model overview

Type	Article number	Description
JSTD20A	2TLA020007R2000	Two-hand device, without emergency stop
JSTD20B	2TLA020007R2100	Two-hand device, with emergency stop
JSTD20C	2TLA020007R2200	Only housing, no buttons

Accessories

Type	Article number	Description
JSTS30	2TLA020007R4000	Floor stand
JSTS31	2TLA020007R4100	Floor stand with distance ring
JSTS32	2TLA020007R4200	Distance ring

The Jokab Safety branded product with article number beginning with 2TLJ is fully compatible with the ABB branded product with article number beginning with 2TLA.

Dimensions

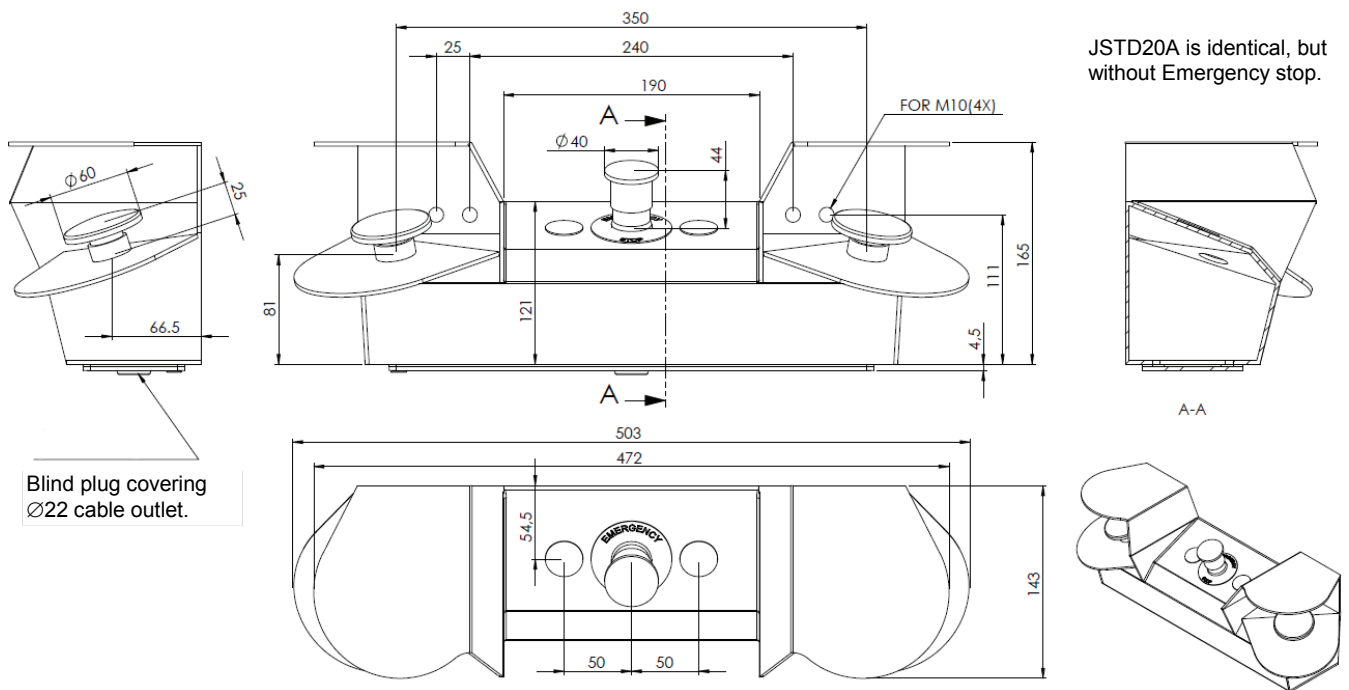

NB: All measurements in millimetres.

7 Technical data

Manufacturer	
Address	ABB JOKAB SAFETY Varlabergsvägen 11 SE-434 39 Kungsbacka Sweden
Electrical characteristics	
Contact material	Silver alloy on brass
Termination	Screw clamp terminals, up to cross section 2.5 mm ² .
Utilisation categories	AC-15 240V 3A DC-13 240V 0.27A
Thermal Current (I _{th})	10A
Rated insulation/withstand voltages	690V rms
Contact resistance	20 mohm
General	
Protection class	IP65
Ambient temperature	-10...+70°C (operating) -20...+70°C (storage)
Size	See drawing
Material	Housing: 3 mm Steel Gasket: Rubber Pushbuttons: Plastic
Colour	Black housing Black pushbutton Black floor stand
Weight	JSTD20: 6.4 Kg JSTS30: 20 Kg JSTS31: 23 Kg
Operating pushbutton	
Diameter	60 mm
Operating force	Approximately 9 N
Operating distance	3.5 ± 1 mm
Mechanical life	10 ⁶ operations
Emergency pushbutton (JSTD20B only)	
Diameter	40 mm
Operating force	40 N
Mechanical life	3x10 ⁵ operations
Contacts	Mechanically separated contact blocks
Operating pushbutton	1 NO + 1 NC
Emergency pushbutton	2 x NC

Safety-related characteristic data and Conformity

Conformity	European Machinery Directive 2006/42/EC EN ISO 12100:2010, EN 574+A1:2008, EN ISO13849-1, EN 60947-1, EN 60947-5-1, EN IEC 60947-5-5, EN ISO 13850, EN ISO 13855
EN ISO 13849-1	Two-hand function: Up to PL e, cat. 4 depending on system architecture
Safety data B10d	Two-hand buttons: 2 x10 ⁶ operations Emergency stop: Fault exclusion, up to 6050 operations
Certifications	Inspecta

8 EC Declaration of conformity

EC Declaration of conformity (according to 2006/42/EC, Annex 2A)	
We	ABB AB JOKAB Safety Varlabergsvägen 11 SE-434 39 Kungälv Sweden
	declare that the safety components of ABB AB make with type designations and safety functions as listed below, is in conformity with the Directive 2006/42/EG
Authorised to compile the technical file	ABB AB JOKAB Safety Varlabergsvägen 11 SE-434 39 Kungälv Sweden
Product	Certificate
Two hand control device JSTD1 (A-C, E-G), Safeball	11-SKM-CM-0108
Two hand control desk JSTD25 (A-H, K, P)	11-SKM-CM-0108 (not including the desk)
Two hand control desk JSTD20 (A-B)	11-SKM-CM-0109
Notified body	Inspecta Sweden AB Box 30100 SE-104 25 Stockholm Sweden Notified body No. 0409
Used harmonized standards	EN ISO 12100:2010, EN 574+A1:2008
Jesper Kristensson PRU Manager Kungälv 2013-06-10	
<hr/> www.abb.com www.jokabsafety.com	
Original	

ABB JOKAB SAFETY Varlabergsvägen 11, SE-434 39 Kungälv, Sweden

www.abb.com/jokabsafety