

Control Engineering 1999 Editors' Choice Award

Enterprise Historian™ Information Security and Accessibility

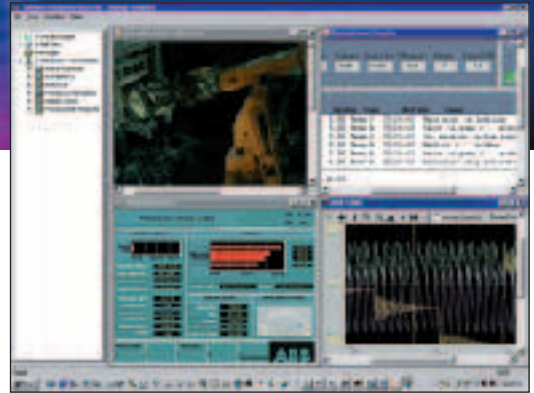
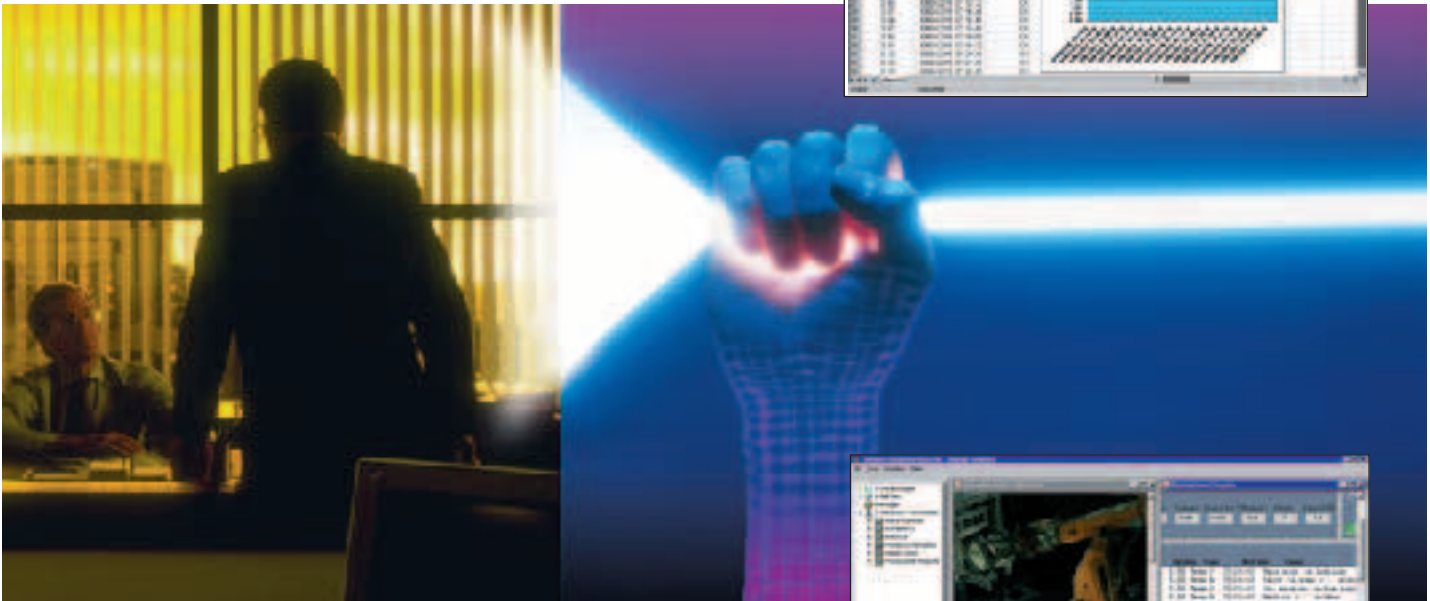
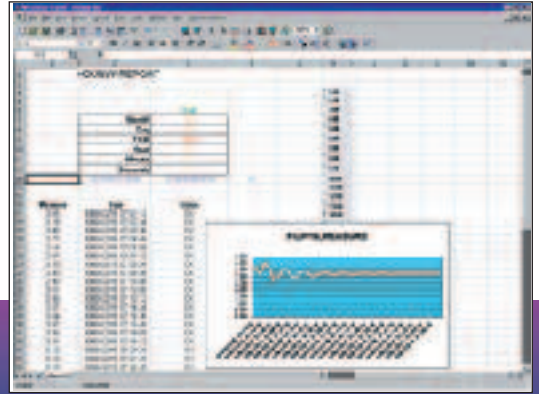

Increase Productivity

Decision Support

With Enterprise Historian, you can increase your productivity by making decisions based on comprehensive plant-wide information. It offers the decision-support architecture you need to collect, store, consolidate and manage data from business, production and automation systems throughout your enterprise. Enterprise Historian's flexible architecture offers comprehensive information management capabilities, on-line storage, saving to external media, display management, integrated data mining and modeling, and automation connectivity.

Enterprise Historian facilitates the integration of Enterprise Resource Planning (ERP), Supply Chain Management (SCM), Manufacturing Execution Systems (MES) and automation systems to provide access to the information you need—when and where you need it. As a decision-making enabler, it increases manufacturing productivity in a number of ways, such as helping you identify bottlenecks, analyze poor operating areas, and recognize changes in performance.



Enterprise Historian provides access to information, when and where you need it.



An Architecture That Works for You

Enterprise Information Management

Enterprise Historian is based upon a distributed, open, client/server architecture which takes advantage of distributed servers for data management and display generation. This distributed architecture eliminates bottlenecks caused when a single server is used as a plant-wide historian. Microsoft and Unix platforms are used as clients to display historical and real-time business information.

The primary components of Enterprise Historian are **Display Services** for distributed graphical user interface; **History Services** for distributed data collection, storage and archiving; **Pavilion Technologies' InSights™** for data mining and modeling; and **Automation Connections** for the consolidation and historization of information from other vendors' automation systems. Enterprise Historian provides local and remote access to geographically distributed enterprise information.

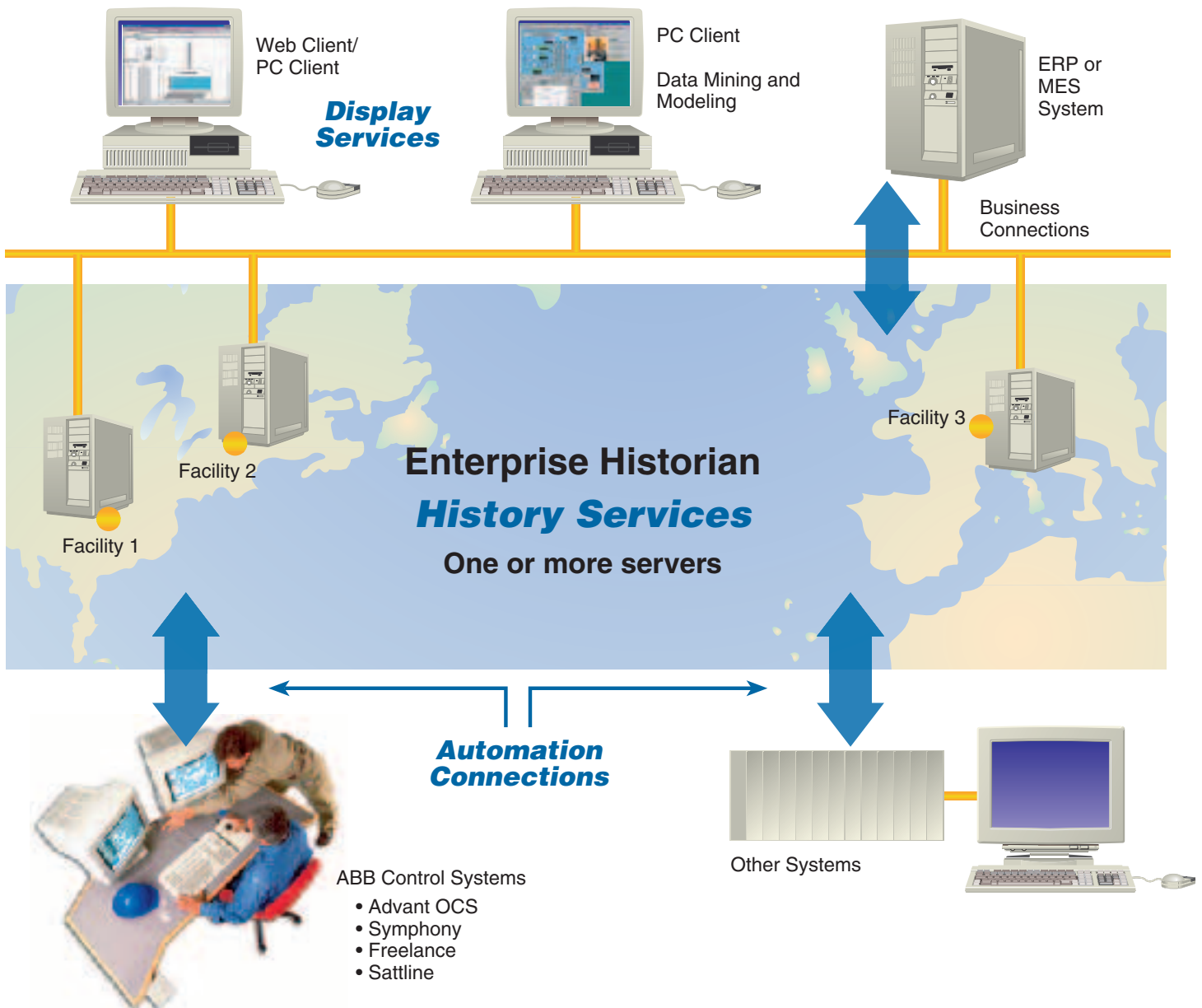

Flexible Data Storage

PDL data is used for easy correlation of batch-to-batch data.

Standard and Custom Formats

Whether your information comes from control systems, manufacturing execution systems, or business systems, Enterprise Historian enables you to store and organize a wide variety of data types or formats. Enterprise Historian preserves the unique properties and characteristics of this information.

Sample data types include polled numeric data from field instruments or smart sensors; manually entered quality data; arrays of data from specialized field devices; profile/contour data; alarm and event messages; operator comments and actions; and order, resource and schedule information. History Services manage all information which is to be stored and ultimately accessed, displayed, and converted into reports for informed decision making.

Custom Production Data Logs

Production Data Log (PDL) is a unique Enterprise Historian data structure. PDL is used to organize critical process information such as equipment usage, task start/stop and duration times, operator interventions, alarms and events, and relationships between events (transactions) and process variables. Typically, this type of information cannot be pre-configured or anticipated. PDL provides

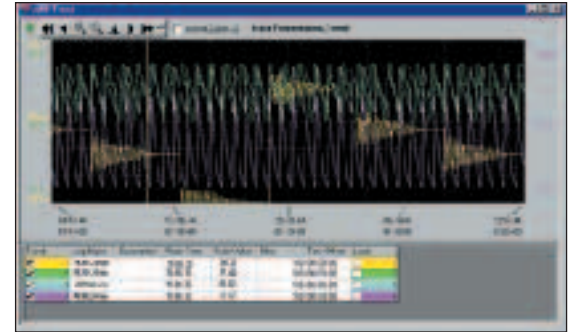

inherent data associations and standard or custom structures for storing and correlating event-based transactions.

You can use PDL to create event associations occurring during a particular part of processing. This gives you an unplanned time-related association, for example, to a temperature profile stored at a relevant time in history. PDL can be populated either automatically or via User API. It has been used for downtime analysis and to determine the utility costs for distinct process operations such as a specific run through a machine of a particular product or grade.

Quality Improvements with PDL

The standard structure for PDL batch processes is based upon jobs, batches, tasks, units, phases, and equipment usage. This relationship structure supports ad hoc queries. For example, you can select batches from a specific time interval to determine the batch IDs of batches

processed on a particular piece of equipment. PDL message and equipment usage associations can also help you identify effective equipment/operator combinations, enabling you to improve operations and product quality.

PDL organizes critical event based process information.

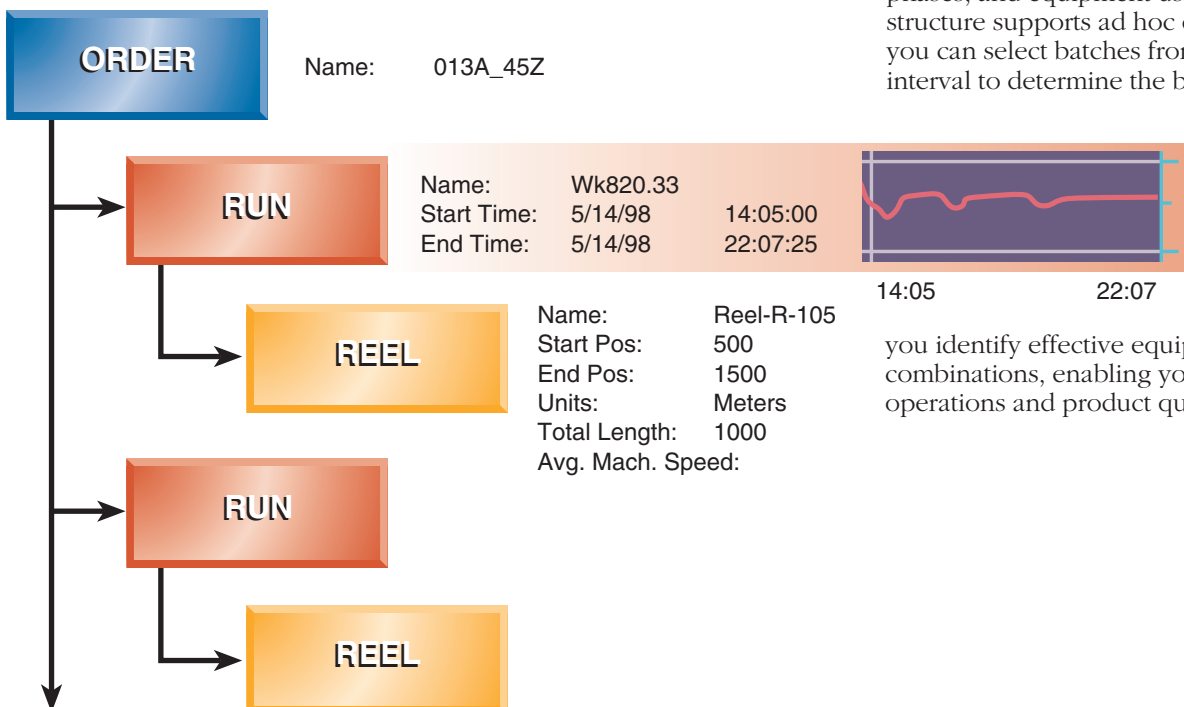

Increased Engineering Efficiency

Enterprise Historian's distributed server architecture enables plant engineers and others to develop innovative historical data configurations and organizational methods. Its architecture and efficient configuration tools make it easy to configure both simple and complex distributed storage strategies.

Flexible, Distributed History

In its simplest form, distributed storage allows you to use a manufacturing information node as a storage location for data. To extend the historical storage of data from one physical location to another, you simply specify the location attribute for the additional distributed historical storage.

You store the most recent information local to the automation network and then "roll it up" to another physical node located at the plant network level. This feature enables you to

consolidate multiple servers' data from various locations without duplicate data configuration or data mirroring.

Quick Configuration

Tools for bulk data configuration enable you to configure large amounts of historical data quickly and efficiently. This permits you to rapidly build your initial historical database and incorporate expansions to the existing historical database. Automation Connections and the bulk data configuration tools expedite expansion of the scope of an existing historical data repository, giving you more information to make enterprise-wide decisions that result in improved productivity.

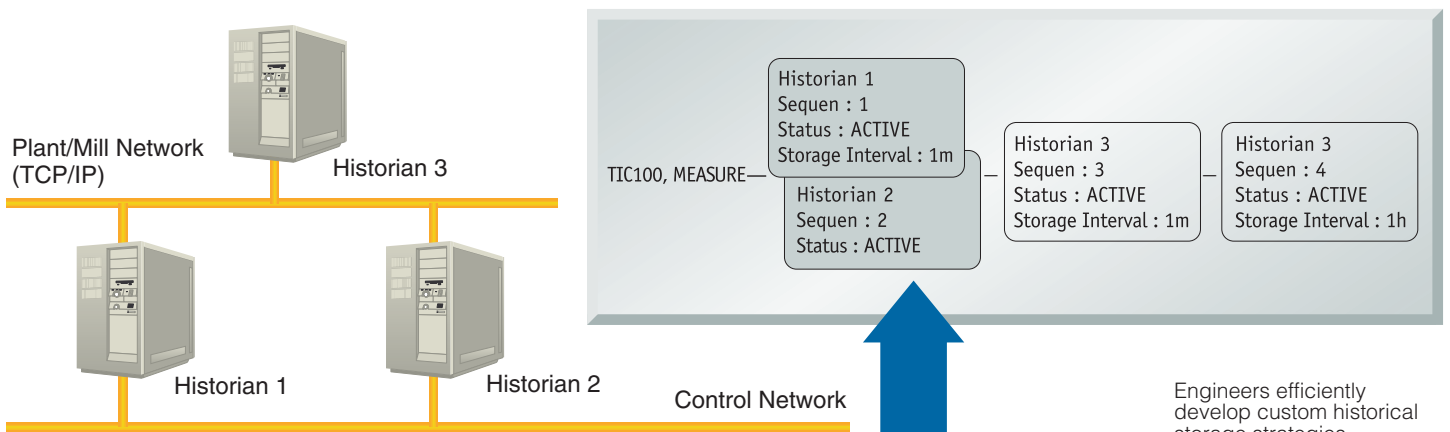

Engineers efficiently develop custom historical storage strategies.

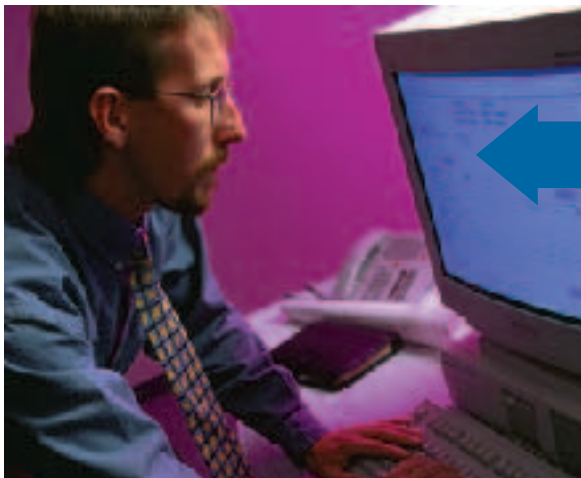

Secure Data Storage

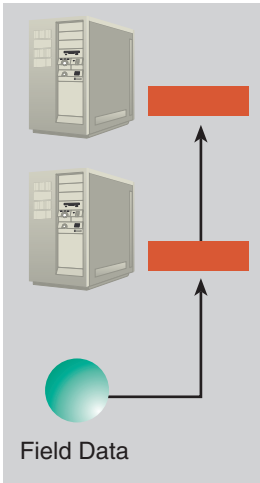

Distributed data storage extends across servers.

Pressures from regulatory and environmental agencies dictate strict guidelines for historical process information retrieval. In many industries, the documented production data is as important as the product itself. To meet your data security requirements and your customers' requirements, Enterprise Historian has built-in security features for historical data storage.

High Data Availability and Security

Storing information in multiple physical locations increases data availability and security. Enterprise Historian's dual data storage feature supports recording of information from one source to various locations. For additional security, distributed data storage supports the distribution of data from the control network to the manufacturing information network. Data for the same time period can be stored at the plant network level without data compaction or loss of resolution from the control network.

The combination of dual and distributed storage provides additional security and high data availability without complicated configuration, as the following example illustrates.

Data is stored concurrently on two independent server nodes on the control network. In addition, another distributed collection point on the plant network is populated from the dual storage. If either primary collection node becomes unavailable, then the distributed collection automatically switches over and is populated by the active primary node. Operators, engineers and others who access the data will see no losses or holes in the data.

Automatic Data Back-Fill

If the distributed collection node unexpectedly becomes unavailable or is scheduled for routine maintenance, the primary collection node automatically back-fills the missed data when the node is back on-line. In the case of dual storage, one of them will back-fill the data.

Depending upon your security requirements, you can use a combination of dual and/or distributed storage to meet your needs. You can build in further security with added hardware using Redundant Arrays of Independent Disks (RAID).

Combined dual and distributed history storage provides automatic switchover for increased data availability and security.

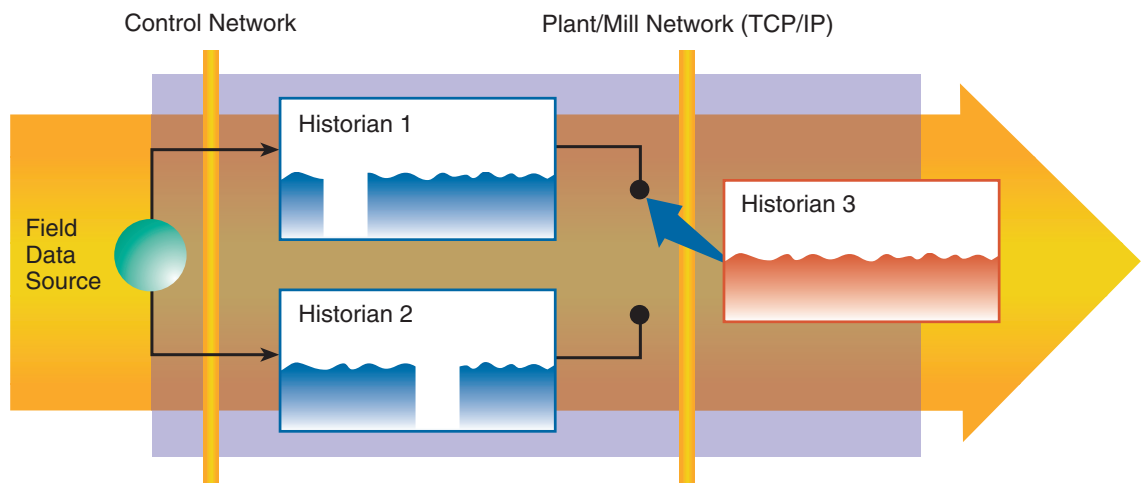

Secure Data Access

Provides Access Authority

Once information is securely stored, secure access must be assured. Since managers, engineers, operators, and others within your organization have differing historical data access needs, Enterprise Historian provides varying degrees of information access via authority levels and passwords. For example, individual users may be assigned view-only or display-building privileges. Individual user access can be limited to a set of displays within an area of responsibility. Each display dictates whether the user can input data or make ad hoc system queries.



Remote access to production information is available through standard web browsers.

Minimal Control Network Loading

Enterprise Historian makes history information available to those who need it while preserving its integrity. It distributes historical data across to a plant network based history server as a secondary storage point, shielding the primary collection node at the control system level from an excessive business level user load. Business level queries can be restricted to the plant network domain. Locally, the collection of important process data continues without the added load of data requests for display and reporting purposes.

Enterprise Historian's distributed architecture gives operators transparent access to process information upstream, downstream, and even from remote system locations. This up-to-date information makes the operator aware of changes that may affect his areas.

Configurable Web Access

Access to process and production information over your company Intranet is available with Web Client. If you have been granted secure access to your company Intranet, either through the corporate network or via modem dial-in, you can use a standard web browser to view displays with runtime and historical information from anywhere. Reports created using Report Services can be stored as HTML or PDF files which can be accessed by and shared with remotely located personnel. This facilitates more informed and timely decisions.

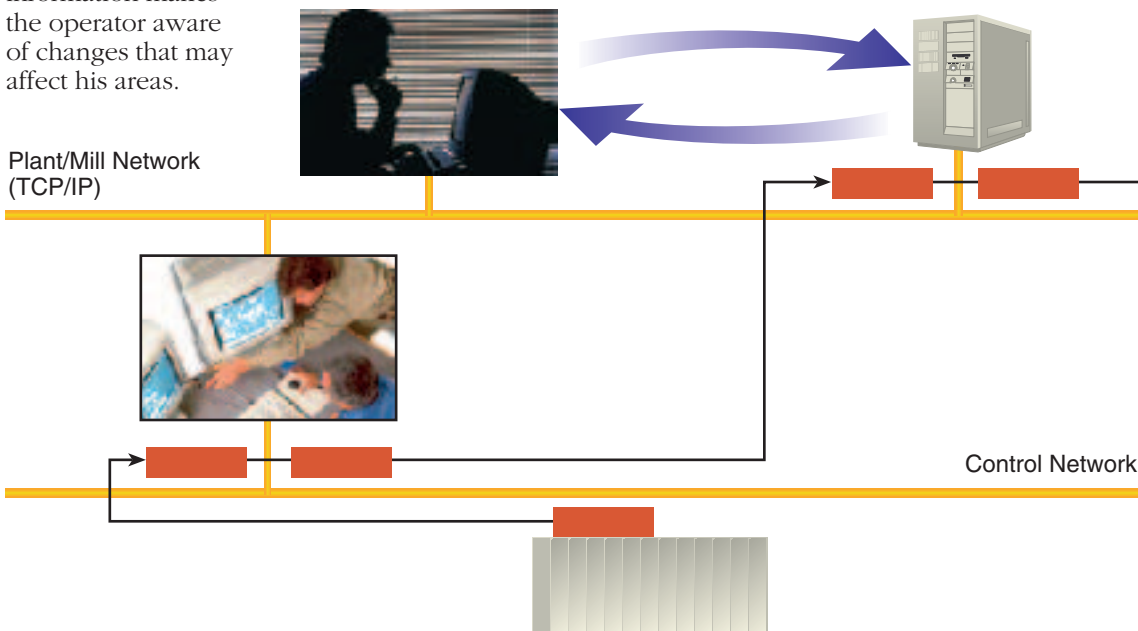

Business level queries can be restricted to the plant network domain, with minimal effects on the collection node.

Enterprise-Wide Accessibility

Physical Boundaries Removed

With production physically distributed across facilities, nations, and the world; managers must be able to analyze, view, and display information from various sites on common displays accessible from their desktop computers. Using Microsoft tools, currently available within the desktop environment, Enterprise Historian's Display Services provide display access to multi-plant history. Production statistics (and other vital information managers require) from multiple sites and multiple facilities can be combined into meaningful displays such as production summaries, efficiency reports and overviews.

Enterprise Historian Display Services provide different desktop views of process, production, and historical information based upon users' needs.

Efficient Display Generation

Enterprise Historian's Windows based display builder provides easy, efficient display engineering. This Graphical User Interface, native to Windows, provides standard usability features including a tree navigation structure, multiple document interface, and the ability to include Active X components in displays. Examples of Active X controls in displays include incorporating movies, live video, Acrobat files and more for standard operating procedures, documentation and troubleshooting tips.

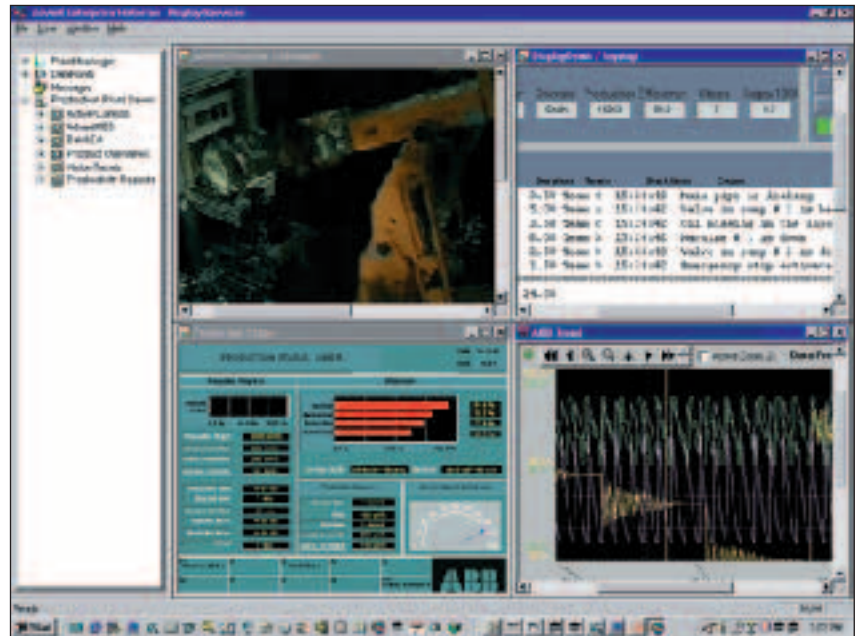
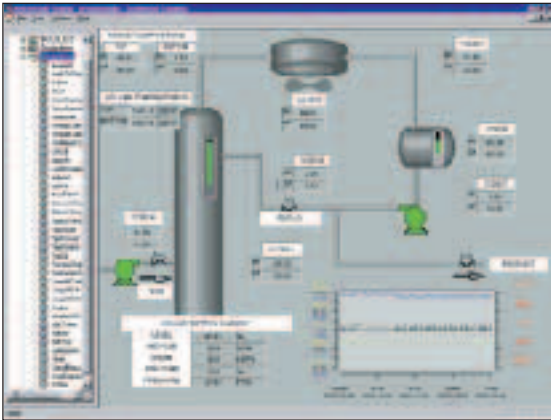

Desktop Accessibility

Excel Add-Ins for Reporting

You can create ad hoc, hourly, shift, and daily reports using tools you are already familiar with and currently use for your daily activities. Simply add DataDirect Excel Add-Ins as part of your Microsoft desktop environment. These Add-Ins provide access through dialog windows on Excel spreadsheets to process variables, history values, and SQL queries. With DataDirect, additional third-party drivers such as ODBC or SQL*Net are not required, eliminating a level of complicated PC configuration and maintenance.

Access to Continuous Data

If you need a current production value such as operating efficiency or a production total from the control system, just choose a cell within Excel and select the process value or historical value icon from the tool bar. You can make a request of any system with an Enterprise Historian Display server, regardless of location, by simply logging in and using dialogs. Managers with little knowledge of the control system can get important information directly, without asking someone else to configure a formal report. Standard report templates can be set up and launched directly from Excel when needed.

Access to Batch Data

Information from the Production Data Log structure is also available through DataDirect Excel Add-Ins. Relationships based upon tasks such as jobs, batches, units, phases, and equipment are easily accessed. You can use this for batch-to-batch comparisons, downtime analysis, and making correlations between process variables and products when PDL is used for historical data associations.

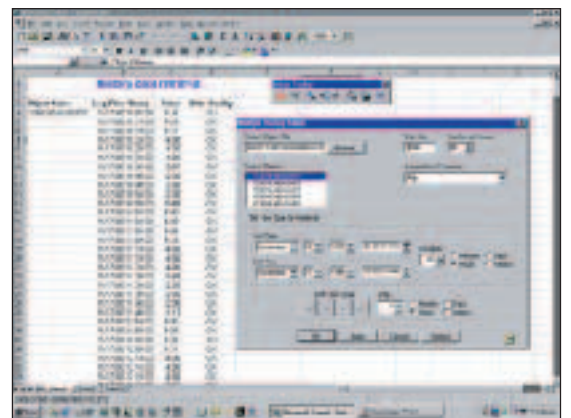
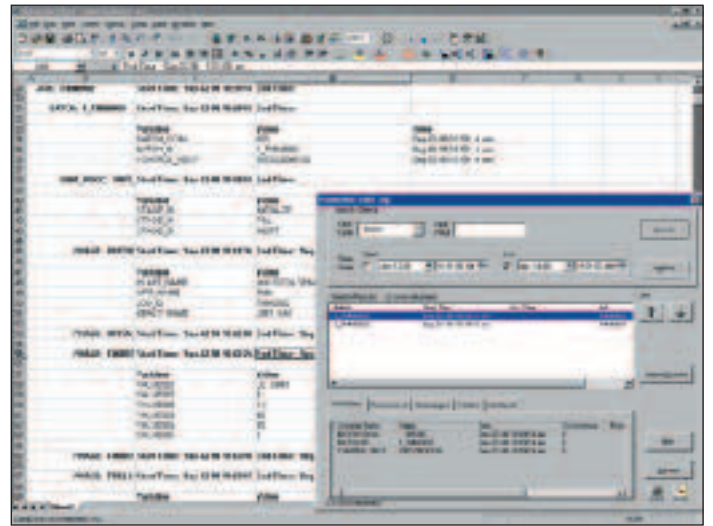

Create reports in the familiar Microsoft desktop environment using DataDirect Excel Add-Ins to access process, production, and historical information.

Tangible Productivity Results

Enterprise Historian is improving productivity for a wide variety of processes in a broad range of industries. ABB's industry experts are available to design solutions using Enterprise Historian that will help you meet your productivity goals. In addition to using historical data for tactical day-to-day decisions, you can also use your enterprise-wide information warehouse for strategic process improvement.

Incorporation of Lab-Entered Data

In the pulp and paper industry, Enterprise Historian is used to generate runtime displays for interactive Reel Reports, Grade Reports and Shift/Day Reports. After a production run, lab technicians can enter asynchronous lab sample values into the historical records. This information is available at operator stations, as well as to managers at their desktops. Security features provide global viewing, but entries and updates are restricted to authorized personnel.

Verification of Batch Quality

In a pharmaceutical application, Enterprise Historian Production Data Logs are used to create Batch Summary Reports. These reports detail the temperatures, flows, and pressures of key process parameters during particular phases within the batch. This information is used by production management to verify product quality and for process validation.



Runtime displays are available for interactive reports.

Cost Savings with Modeling

In a chemical facility, data is mined from Enterprise Historian and exported to the integrated Pavilion software suite for modeling and optimization. Reliable historical data with high availability is transferred in a timely manner. One week's worth of history data, consisting of approximately 2,000,000 values, is exported in approximately two minutes. During the switchover between products, this historical information is modeled and analyzed to make cost-saving decisions regarding the quality of the interim products produced.

Improved Resource Scheduling

In an energy intensive flat-sheet application, cost effectiveness and inefficiencies are identified based upon the mass balance of the steam, water, and gas in relation to the product that is being manufactured. This information is used to determine the relationships between optimal machine usage versus the product grade produced and in shift-productivity displays. Management uses these displays for improved resource scheduling.



Modeling and analyzing information using Insights provides knowledge for cost-saving decisions.



Control Engineering 1999 Editors' Choice Award



E-mail: EnterpriseHistorian@us.abb.com



To arrange a personal consultation, call ABB Automation at the office nearest you:

Regional Center Sweden

Västerås, Sweden

Telephone 46 (0) 21-34-2000

Telefax 46 (0) 21-13-7845

Regional Center Americas

Wickliffe, OH USA

Telephone 1 (440) 585-8500

Telefax 1 (440) 585-8756

Regional Center Germany

Mannheim, Germany

Telephone +49 (0) 180 5 266776

Telefax +49 (0) 180 5 776329