

Please note!

This model of Eden is obsolete and has been replaced by Eden DYN



Original instructions

# Eden

## Non-contact safety sensor



## Read and understand this document

Please read and understand this document before using the products. Please consult your ABB JOKAB SAFETY representative if you have any questions or comments.

### **WARRANTY**

ABB JOKAB SAFETY's exclusive warranty is that the products are free from defects in materials and workmanship for a period of one year (or other period if specified) from date of sale by ABB JOKAB SAFETY.

ABB JOKAB SAFETY MAKES NO WARRANTY OR REPRESENTATION, EXPRESSED OR IMPLIED, REGARDING NON-INFRINGEMENT, MERCHANTABILITY, OR FITNESS FOR PARTICULAR PURPOSE OF THE PRODUCTS, ANY BUYER OR USER ACKNOWLEDGES THAT THE BUYER OR USER ALONE HAS DETERMINED THAT THE PRODUCTS WILL SUITABLY MEET THE REQUIREMENTS OR THEIR INTENDED USE. ABB JOKAB SAFETY DISCLAIMS ALL OTHER WARRANTIES, EXPRESSED OR IMPLIED.

### **LIMITATIONS OF LIABILITY**

ABB JOKAB SAFETY SHALL NOT BE RESPONSIBLE FOR SPECIAL, INDIRECT, OR CONSEQUENTIAL DAMAGES, LOSS OF PROFITS OR COMMERCIAL LOSS IN ANY WAY CONNECTED WITH THE PRODUCTS, WHETHER SUCH CLAIM IS BASED ON CONTRACT, WARRANTY, NEGLIGENCE, OR STRICT LIABILITY.

In no event shall responsibility of ABB JOKAB SAFETY for any act exceed the individual price of the product on which liability asserted.

IN NO EVENT SHALL ABB JOKAB SAFETY BE RESPONSIBLE FOR WARRANTY, REPAIR, OR OTHER CLAIMS REGARDING THE PRODUCTS UNLESS ABB JOKAB SAFETY'S ANALYSIS CONFIRMS THAT THE PRODUCTS WERE PROPERLY HANDLED, STORED, INSTALLED, AND MAINTAINED AND NOT SUBJECT TO ABUSE, MISUSE, OR INAPPROPRIATE MODIFICATION OR REPAIR.

### **SUITABILITY FOR USE**

ABB JOKAB SAFETY shall not be responsible for conformity with any standards, codes, or regulations that apply to the combination of products in the customer's application or use of the product. At the customer's request, ABB JOKAB SAFETY will provide applicable third party certification documents identifying ratings and limitations of use that apply to the products. This information by itself is not sufficient for a complete determination of the suitability of the products in combination with the end product, machine, system, or other application or use.

The following are some examples of applications for which particular attention must be given. This is not intended to be an exhaustive list of all possible uses of the products, nor is it intended to imply that the uses listed may be suitable for the products:

Outdoor use, uses involving potential chemical contamination or electrical interference, or conditions or uses not described in this document.

Nuclear energy control systems, combustion systems, railroad systems, aviation systems, medical equipment, amusement machines, vehicles, and installations subject to separate industry or government regulations.

Systems, machines, and equipment that could present a risk to life or property.

Please know and observe all prohibitions of use applicable to the products.

NEVER USE THE PRODUCTS FOR AN APPLICATION INVOLVING SERIOUS RISK TO LIFE OR PROPERTY WITHOUT ENSURING THAT THE SYSTEM AS A WHOLE HAS BEEN DESIGNED TO ADDRESS THE RISKS, AND THAT THE ABB JOKAB SAFETY PRODUCT IS PROPERLY RATED AND INSTALLED FOR THE INTENDED USE WITHIN THE OVERALL EQUIPMENT OR SYSTEM.

### **PERFORMANCE DATA**

While every effort has been taken to ensure the accuracy of the information contained in this manual ABB JOKAB SAFETY cannot accept responsibility for errors or omissions and reserves the right to make changes and improvements without notice. Performance data given in this document is provided as a guide for the user in determining suitability and does not constitute a warranty. It may represent the result of ABB JOKAB SAFETY'S test conditions, and the users must correlate it to actual application requirements. Actual performance is subject to the ABB JOKAB SAFETY Warranty and Limitations of Liability.

## Table of Contents

Read and understand this document.....	2
<b>1 Introduction .....</b>	<b>4</b>
Scope.....	4
Audience .....	4
Prerequisites.....	4
Special notes .....	4
<b>2 Overview .....</b>	<b>5</b>
General description.....	5
Safety regulations .....	5
<b>3 Connections .....</b>	<b>6</b>
Connection examples .....	7
<b>4 Installation and maintenance .....</b>	<b>9</b>
Installation precautions .....	10
Maintenance .....	11
Testing of the safety functions .....	11
Troubleshooting .....	11
<b>5 Operation .....</b>	<b>12</b>
LED indication.....	12
Information output signal attributes.....	12
<b>6 Model overview.....</b>	<b>13</b>
Accessories.....	13
<b>7 Technical data .....</b>	<b>14</b>
<b>8 EC Declaration of conformity .....</b>	<b>17</b>

# 1 Introduction

## Scope

The purpose of these instructions is to describe the non-contact safety sensor Eden and to provide the necessary information required for installation and operation.

## Audience

This document is intended for authorized installation personnel.

## Prerequisites

It is assumed that the reader of this document has knowledge of the following:

- Basic knowledge of ABB Jokab Safety products.
- Knowledge of machine safety.

## Special notes

Pay attention to the following special notes in the document:

 **Warning!** Danger of severe personal injury!  
An instruction or procedure which, if not carried out correctly, may result in injury to the technician or other personnel.

**Caution!** Danger of damage to the equipment!  
An instruction or procedure which, if not carried out correctly, may damage the equipment.

NB: Notes are used to provide important or explanatory information.

## 2 Overview

### General description

Eden is a non-contact safety sensor consisting of two separate devices – Adam and Eva – for use on interlocked gates, hatches etc. A dynamic signal is transmitted from the control device Vital or safety-PLC Pluto via Adam to Eva who sends it back again. The maximum sensing distance between Adam and Eva is 15 mm +/- 2 mm. Up to 30 Eden sensors can be connected to Vital and 10 Eden sensors per input can be connected to Pluto and still achieve the same safety level on the safety circuit. It is also possible to connect safety light beams, Tina adaptor units and E-stops on the same safety circuit.

Adam is available with an M12-connector or with an integrated cable of up to 20 m. Eden E is designed for harsh environments and with its protective housing it achieves protection class IP69K (maximum sensing distance for Eden E is 12 mm +/- 2 mm).

The Jokab Safety branded product with articlenumber beginning with 2TLJ is fully compatible with the ABB branded product with articlenumber beginning with 2TLA.

### Safety regulations

#### Warning!

Carefully read through this entire manual before using the device.

The devices shall be installed by a trained electrician following the Safety regulations, standards and the Machine directive.

Failure to comply with instructions, operation that is not in accordance with the use prescribed in these instructions, improper installation or handling of the device can affect the safety of people and the plant.

For installation and prescribed use of the product, the special notes in the instructions must be carefully observed and the technical standards relevant to the application must be considered.

In case of failure to comply with the instructions or standards, especially when tampering with and/or modifying the product, any liability is excluded.

NB: This is a class A product. In a domestic environment this product may cause radio interference in which case the user may be required to take adequate measures.

### 3 Connections

#### Eden electrical connections

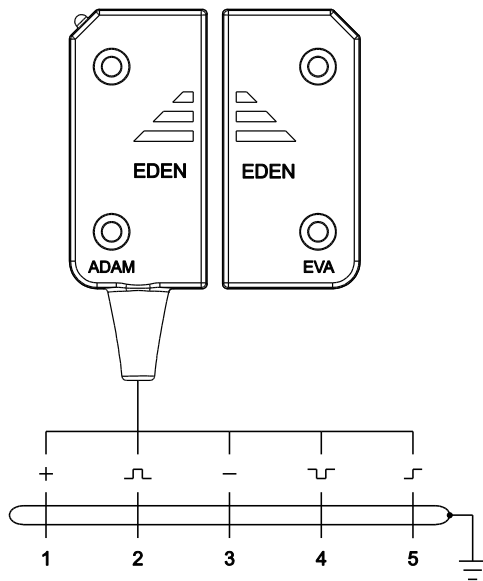

#### M12-connector: (5-pole male)

- 1 ) Brown: +24 VDC
- 2 ) White: Dynamic signal input
- 3 ) Blue: 0 VDC
- 4 ) Black: Dynamic signal output
- 5 ) Grey: Information output

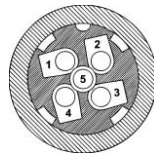

M12 5-pole male seen  
from cable side

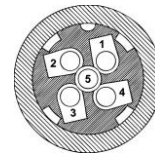

M12 5-pole female  
seen from cable side

NB: Shielded cable is recommended between this unit and the rest of the safety circuit.

**Caution!** All cable colours according to ABB Jokab Safety standard cables.

**Warning!** Eden is equipped with an information output able to indicate the status of the sensor. The information channel output is non-safe and should **never** be used for the safety function. The only signals intended for safety functions are the safe dynamic signals.

## Connection examples

### Connection example: Two Eden and one Spot T/R connected to Pluto safety-PLC

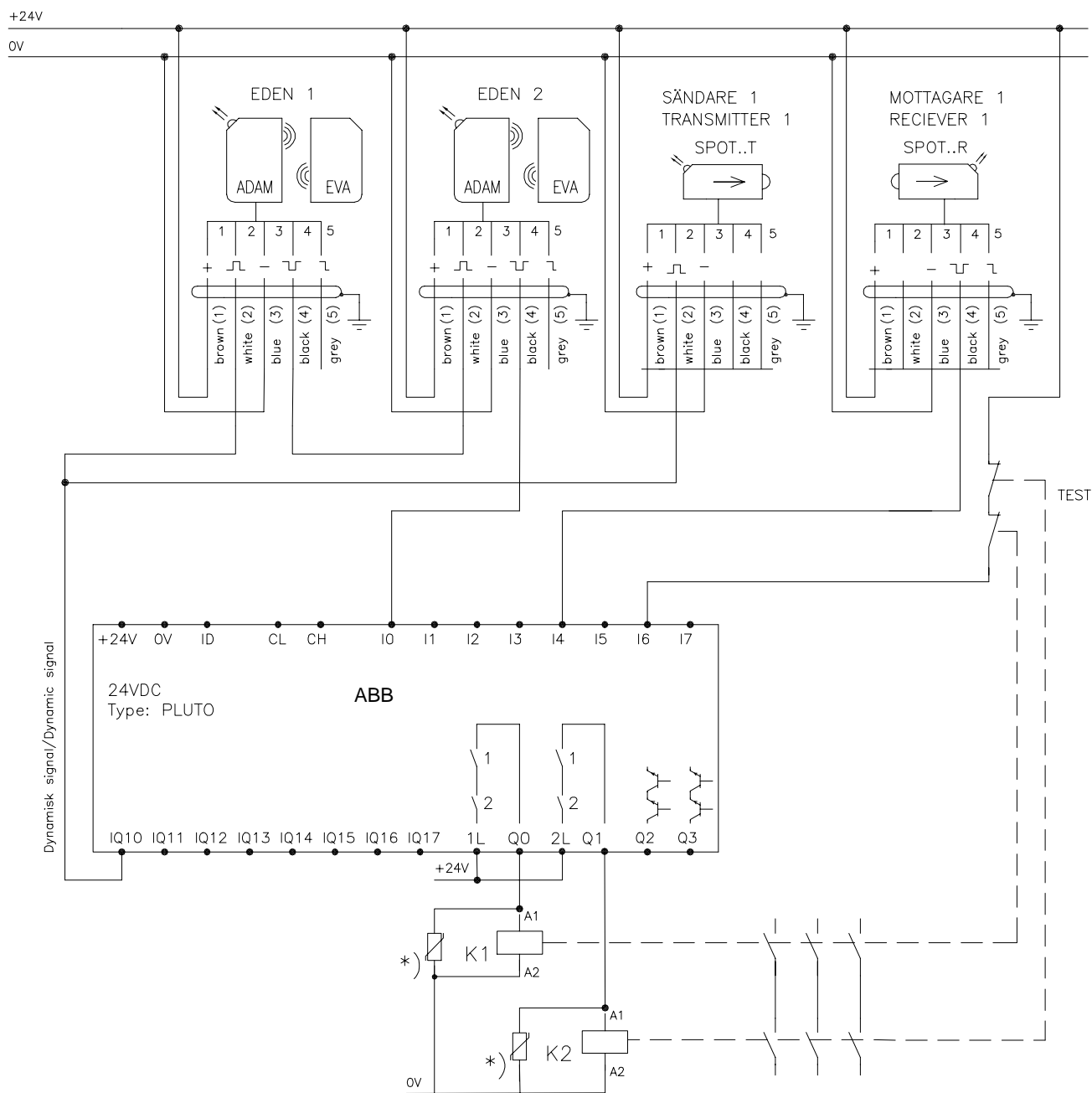

\*)OBS: Använd alltid transientskydd t.ex. VDR!  
 \*)NOTE: Always use transient suppressors, e.g. VDR's!

**Caution!** All cable colours according to ABB Jokab Safety standard cables.

Connection example: Different sensors connected to Vital 1 safety module

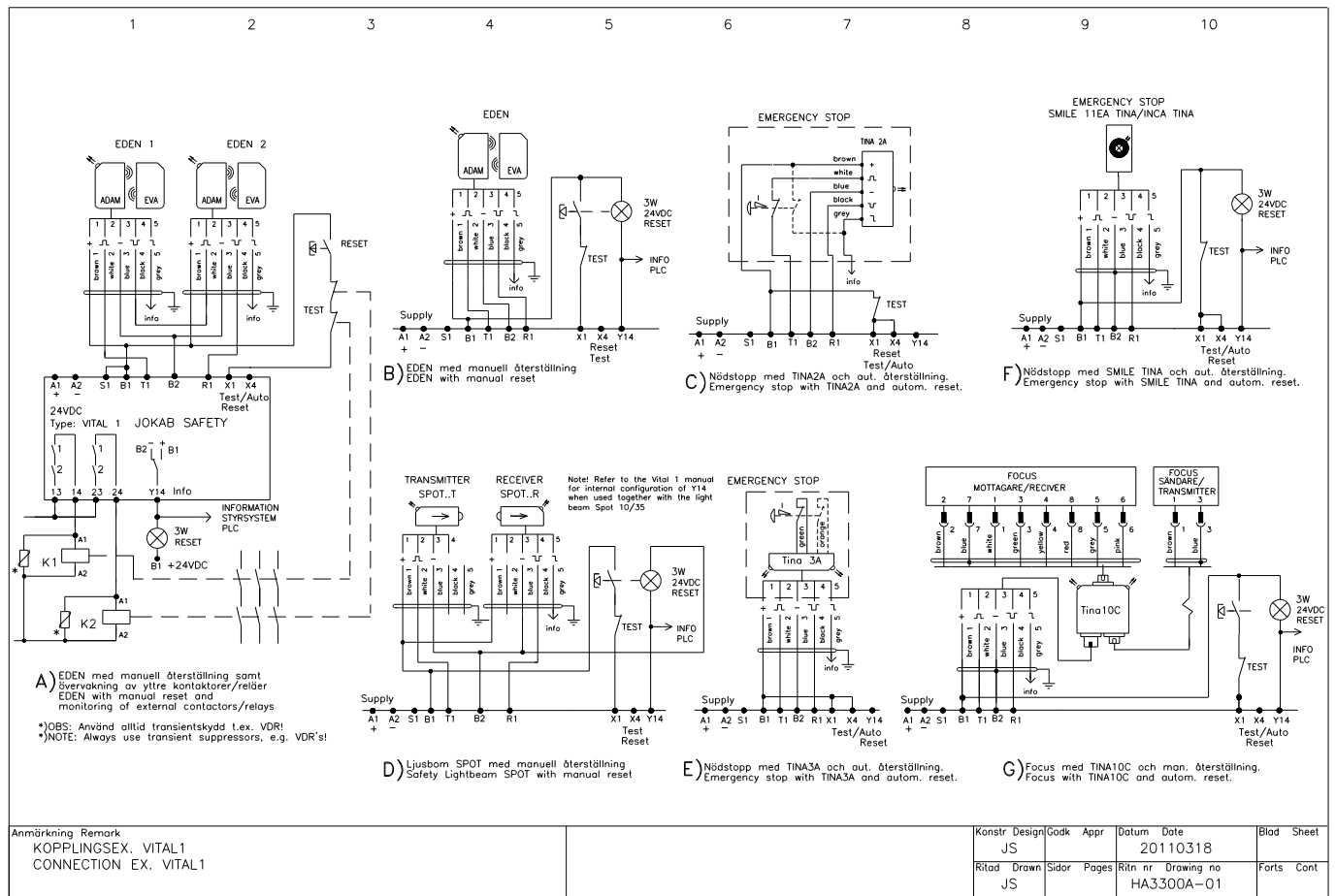

Caution! All cable colours according to ABB Jokab Safety standard cables.



## 4 Installation and maintenance

Eva can be turned in a number of different ways relative Adam, see details in the figure below. Depending on the cable connector used to connect to Eden, different distance plates can be necessary in order to avoid damage to Adam. The protection plates (DA1) supplied with Adam M12-models are recommended for this, see figure below. Also, the mounting spacers supplied must be used in order to physically protect Eden from damage.

Use two M4-screws to fasten each sensor. Safety screw SM4x20 (Eden) and SM4x25 (Eden E) are recommended. Use max tightening torque 2 Nm. Lock screw using Loctite or similar to prevent easy dismounting if necessary (refer to risk assessment).

### Eden installation

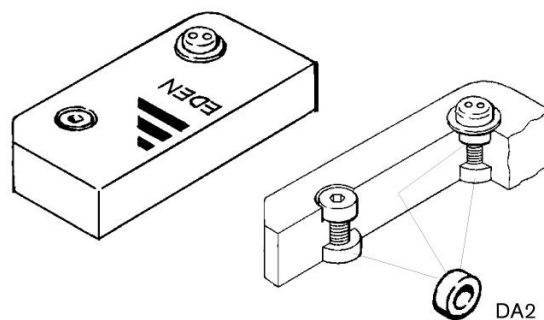
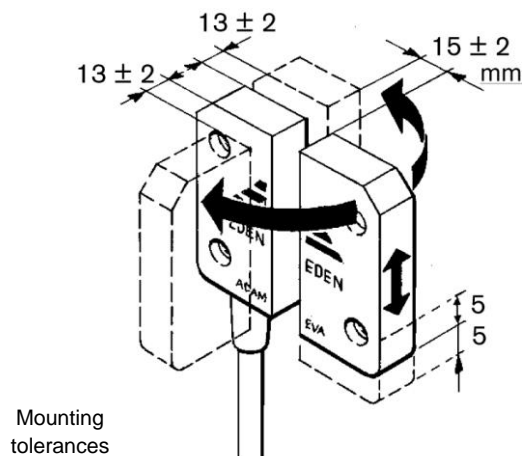

The DA2 mounting spacer **must be** used in order to physically protect Eden from damage.

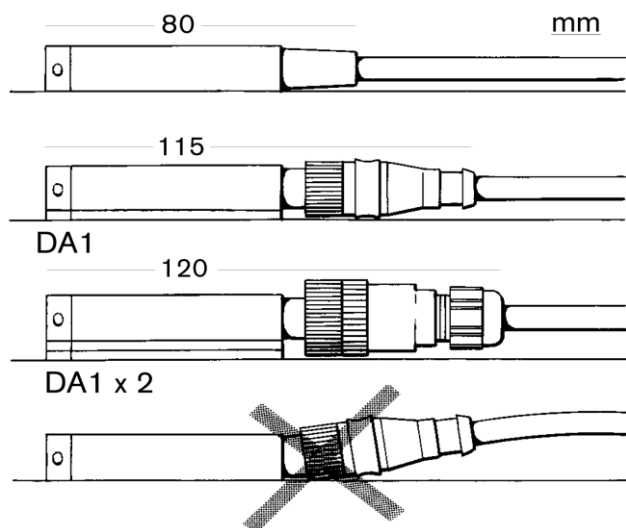

Mounting Adam with integral cable.

Mounting with one protection plate (DA1) for Adam M12 using prewired moulded M12 connector

Mounting with two protection plates (DA1) for Adam M12 using M12 connector with glanded cable.

Incorrect mounting without protection plate may cause permanent damage to sensor.

Maximum sensing distance between Adam and Eva:

Eden: 15 mm +/- 2 mm

Eden E: 12 mm +/- 2 mm

Minimum distance between two Eden pairs:

50 mm

## Cable mounting

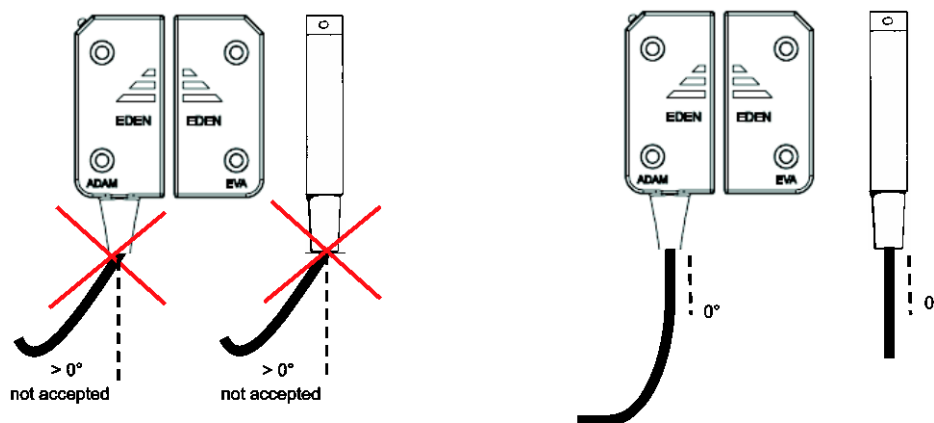

The cable should be mounted so there is no force on Adam sensor in any directions. The cable should be fixed if it's connected to a moving object, for example a cable chain or a door. This can be done with for example two cable clamps. This applies to all versions of Adam, including Adam E and Adam with M12-contact.

An improperly installed cable can damage the sensor.

## Minimum safety distance

When using interlocking guards without guard locking to safeguard a hazard zone, the minimum allowed safety distance between the guarded opening and the hazardous machine must be calculated. In order to ensure that the hazardous machine motion will be stopped before it can be reached, the minimum safety distance is calculated according to EN ISO 13855 ("Positioning of safeguards with respect to the approach speeds of parts of the human body").

The minimum safety distance is calculated according to the formula:

$$S = (K \times T) + C$$

Where

**S** = minimum safety distance (mm)

**K** = approach speed of a human body; 1600 mm/s

**T** = the total time from opening of the guard until the hazardous machine movement has stopped, i.e. including control system reaction times and other delays (s)

**C** = a safety distance taken from Table 4 or Table 5 of EN ISO 13857:2008, if it is possible to push fingers or a hand through the opening towards the hazard before a stop signal is generated

NB: In some cases, T might be reduced by the opening time of the guard until the opening size permits access of the relevant parts of the body. Refer to EN ISO 13855 for further details and EN ISO 13857 for specified values.

## Installation precautions

- Note that the sensing distance may change when the sensor is fitted onto metals. Mount Adam and Eva to the intended operating position and test and adjust the sensing distance. Distance plates DA1 can also be used between the sensor and mounting bracket to avoid direct contact with the metal.
- Use max tightening torque 2 Nm when mounting the sensors.
- Control that Adam and Eva are aligned in parallel to each other.
- The cable to Adam should be U-shaped if the units are mounted in wet areas.

 **Warning!** All the safety functions must be tested before starting up the system.

## Maintenance

### Warning!

The safety functions and the mechanics shall be tested regularly, at least once every year to confirm that all the safety functions are working properly (EN 62061:2005).

In case of breakdown or damage to the product, contact the nearest ABB Jokab Safety Service Office or reseller. Do not try to repair the product yourself since it may accidentally cause permanent damage to the product, impairing the safety of the device which in turn could lead to serious injury to personnel.

### Testing of the safety functions

Make sure the safety unit is working properly by following these steps:

- Interrupt protection by moving Eva away from Adam. The LED will light red when Eva is out of position relative Adam.
- Interrupt the dynamic safety circuit before this unit. The LED will flash between green and red.
- Move Eva to position next to Adam. The LED will light green if the safety circuit(s) before this unit is not interrupted.

An additional function test can be made by slowly moving Eva away from Adam. The LED will flash fast between green and red when Eva is 2 mm from max sensing distance to Adam.

### Troubleshooting

LED indication	Expected causes of faults	Checking and measures to take
Lights red	Eva away	Move Eva closer to Adam
	Metal (iron) between Eden	Remove the metal
	24 VDC input to pin-2 (no dynamic signal)	Check if there is 24 VDC to input (pin-2). If Yes, check cable or unit before and fix it.
No lights	Loss of power supply	Check 24 VDC / 0 VDC power supply
Lights green (but no dynamic output detected)	Defected dynamic signal input to unit (asymmetric pulses)	Check the dynamic input or the unit before
Lights green/red (flashing)	No dynamic input (Eva in position with Adam), or info-output (pin-5) connected to 0 VDC	Check the unit before (make it active). Check the info-output, fix it.
Weak lights or red and green lights at the same time	The unit is defect	The unit needs to be replaced. Contact ABB Jokab Safety.

 **Warning!** Replace a defected unit with a new one and never bypass the safety circuit using Tina 1A or any other solution.

## 5 Operation

### LED indication

#### Operation status LED

LED	Indication	Description
LED on Adam	Green	Eva close, safety circuit closed
	Green-Red (flash)	Eva close, safety circuit broken by a previous unit
	Green-Red (flash fast)	Eva within ~2 mm of max sensing distance
	Red	Eva distant, safety circuit broken

### Information output signal attributes

When Eva is in contact with Adam, the information output of the unit (pin-5) is set either high (+24 VDC) or low (0 VDC) depending on four different input signals (pin-2):

- **Dynamic signal** - Dynamic signal input exist, i.e. the safety circuit is OK up until this unit
- **No dynamic signal** - Dynamic signal input does not exist, i.e. the safety circuit is interrupted before this unit.
- **+24 VDC** - A constant +24 VDC signal is applied = high (H)
- **0 VDC** - The pin is connected to 0 VDC = low (L)

The information output signal depends on the input signal according to the table below. Note that if the safety is interrupted, i.e. if Eva is away from Adam, the information output signal is always low (L).

Input signal (pin-2)	Dynamic signal	No dynamic signal	+24 VDC	0 VDC
Info output signal (pin-5)	High	High	Low	High

The delay for switching the information signal output from high to low (H → L) and low to high (L → H) is given in the table below.

Info output signal switch	H → L	L → H
Delay	~ 135 ms	~ 2 ms

 **Warning!** The information output signal is not a failsafe signal and should **never** be used for the safety purpose(s).

## 6 Model overview

Type	Article number	Description
Eva	2TLA020046R0000	Eva
Eva E	2TLA020046R0600	Eva E, protective housing (IP69K)
Adam M12	2TLA020051R0000	Adam, 5-pole M12 connector, 4x protection plates (DA1)
Adam 3 m	2TLA020051R0200	Adam, 5-pole cable, 3 m
Adam E 5 m	2TLA020051R0300	Adam E, 5-pole cable, 5 m, protective housing (IP69K)
Adam 10 m	2TLA020051R0400	Adam, 5-pole cable, 10 m
Adam 20 m	2TLA020051R0500	Adam, 5-pole cable, 20 m
Adam E 10 m	2TLA020051R0600	Adam E, 5-pole cable, 10 m, protective housing (IP69K)
Adam E 0.5 m M12	2TLA020051R0700	Adam E, 5-pole cable with M12 connector, 0.5 m, protective housing (IP69K)
Adam E 20 m	2TLA020051R0800	Adam E, 5-pole cable, 20 m, protective housing (IP69K)

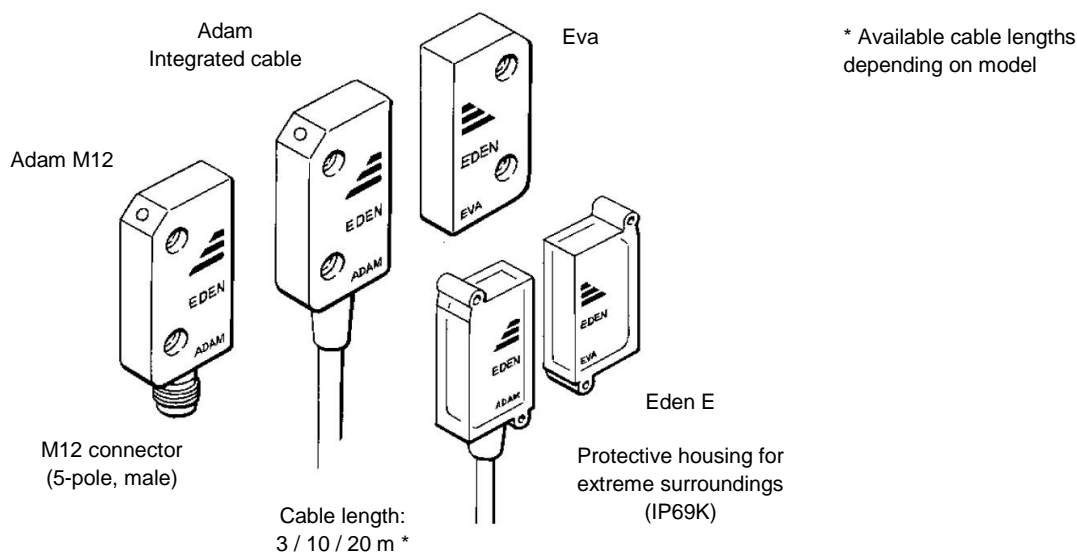

Some Eden models are available in grey; refer to your ABB Jokab Safety sales representative for more information.

### Accessories

Type	Article number	Description
DA1	2TLA020053R0000	Protection plate
DA2	2TLA020053R0100	Mounting spacer
-	2TLA020053R4200	Safety screw SM4 x 20, for mounting Adam and Eva
-	2TLA020053R4300	Safety screw SM4 x 25, for mounting Adam E and Eva E
-	2TLA020053R5000	Safety screwdriver bit SBITS

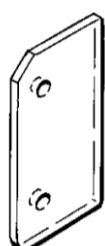

Protection plate (DA1)



Safety screws and screwdriver bit



## 7 Technical data

Manufacturer	
Address	ABB JOKAB SAFETY Varlabergsvägen 11 SE-434 39 Kungsbacka Sweden
Power supply	
Operating voltage	24 VDC +15 %, -25 %
Total current consumption	45 mA (55 mA with max information output) Information output: Max 10 mA
Time delay t (in/out) Eden	t < 60 µs
General	
Protection class	Eden: IP67 Eden E: IP69K
Ambient temperature	
Eden	Storage: -25...+70°C Operation: -25...+70°C
Eden E	Storage: -40...+70°C Operation: -25...+70°C
Humidity range	35 to 85 % (with no icing or condensation)
Housing material	Eden: Based on polyamide, Macromelt OM646 (V0) Protective housing (Eden E): Polyurethane (PU)
Connector	M12 5-pole male (Adam M12, Adam E 0.5 m M12) 5-pole cable 3 m (Adam 3 m) 5-pole cable 10 m (Adam 10 m, Adam E 10 m) 5-pole cable 20 m (Adam 20 m, Adam E 20 m) Cables (5-pole + screen): Material: PVC, UL2464 Cable size: ø5.7 mm Conductor size: 0.34 mm <sup>2</sup>
Size	See drawings below
Mechanical life	10 <sup>7</sup> cycles
Weight	Eva: 26 g Eva E: 36 g Adam M12: 30 g
Colour	Yellow or grey depending on model, black text
Maximum detection distance (Hysteresis approx 1 mm)	Eden: 15 +/- 2 mm Eden E: 12 +/- 2 mm
Assured release distance (S <sub>ar</sub> )	Eden: 45 mm Eden E: 36 mm
Assured operating distance (S <sub>ao</sub> )	Eden: 7.5 mm Eden E: 6 mm
Chemical resistance	
Macromelt (Eden and Eden C)	Cutting oils, vegetable and animal oils, hydrogen peroxide, diluted acids and bases: Good. Alcohol and strong acids: Not recommended.
Polyurethane (PU) (Eden E and Eden EC)	Cutting oils, vegetable and animal oils, hydrogen peroxide, diluted acids and bases, alcohol: Good. Strong oxidation acids: Not recommended.

**Safety / Harmonized standards**

Conformity	European Machinery Directive 2006/42/EC <b>CE</b> EN ISO 12100-1:2010, EN 954-1:1996, EN ISO 13849-1:2008, EN 62061:2005, EN 62061:2005, EN 61508:2010, EN 60204-1:2006+A1:2009, EN 60664-1:2007, EN 61000-6-2:2005, EN 61000-6-4:2007, EN 60947-5-1:2004, EN 1088+A2:2008
IEC/EN 61508-1...7	SIL3, PFH <sub>d</sub> : 4.50*10 <sup>-9</sup>
EN 62061	SIL3
EN ISO 13849-1	Performance level: Pl e, category 4
Certificates	TÜV Nord

The Jokab Safety branded product with article number beginning with 2TLJ is fully compatible with the ABB branded product with article number beginning with 2TLA.

**Intended use**

NB! These restrictions are only according to certification for CSA (Canada/USA).

- Pollution degree, 2
- Installation category N/A
- Altitude, 2000 m (max)
- Humidity, 80 % max for temperatures up to 31 °C and 35-85 % without condensation
- Electrical supply < 2 W, 24 VDC
- Indoor use statement
- Temperature, -10 to 55 °C.

**Dimensions**

**Eden dimensions**

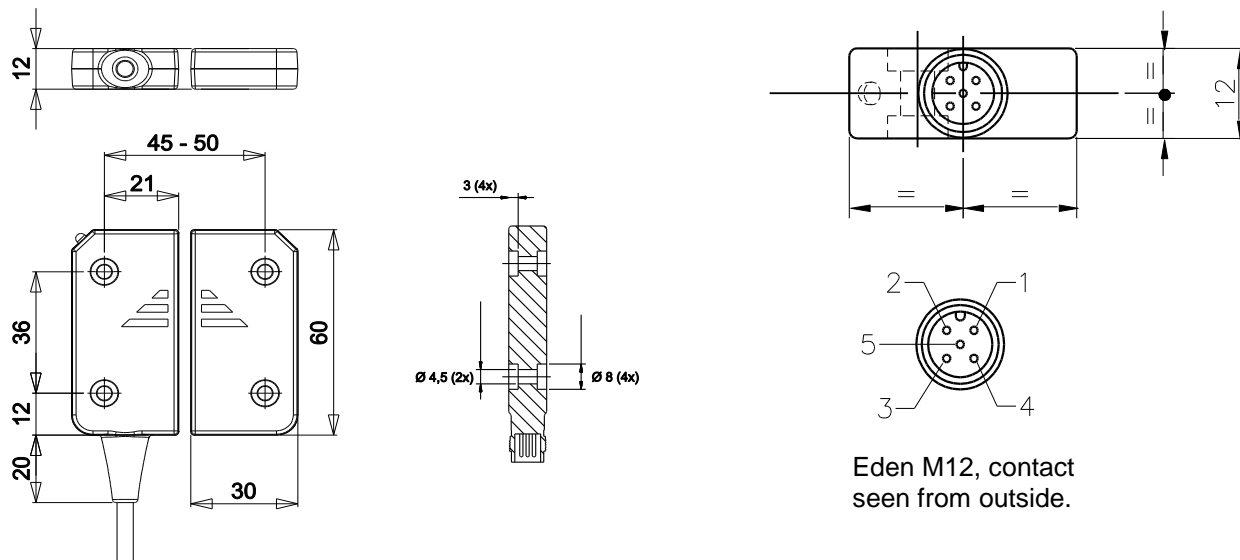

Eden M12, contact seen from outside.

### Eden E dimensions

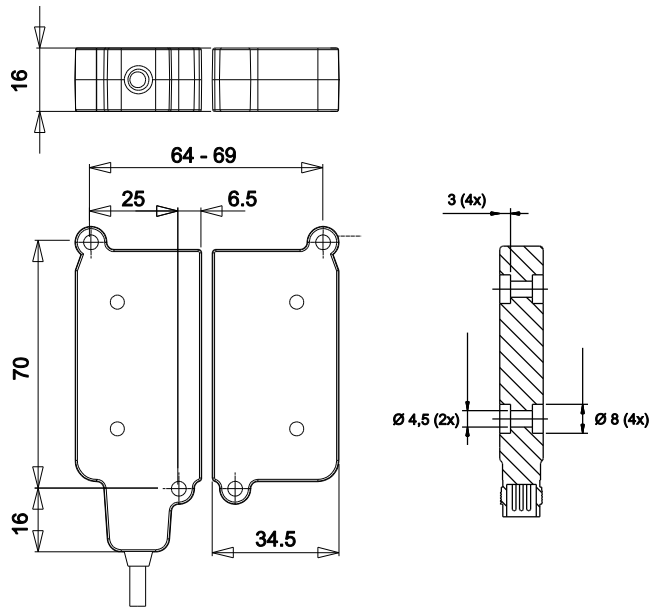

NB: All measurements in millimetres.



## 8 EC Declaration of conformity



### EC Declaration of conformity

(according to 2006/42/EC, Annex 2A)

We ABB AB  
JOKAB SAFETY  
Varlbergsvägen 11  
SE-434 39 Kungsbacka  
Sweden

declare that the safety components of ABB AB make with type designations and safety functions as listed below, is in conformity with the Directives

2006/42/EC  
2006/95/EC  
2004/108/EC

Authorised to compile the technical file

ABB AB  
JOKAB SAFETY  
Varlbergsvägen 11  
SE-434 39 Kungsbacka  
Sweden

<u>Product</u>	<u>Certificate</u>	<u>Serialnumber</u>
Non-contact safety sensor Eden (Adam, Eva) E/C/EC	44 799 12 408341-003	[000 – 000 ... 999-999]
Adapter unit Tina 1-8, Tina 10-12	44 799 12 408341-003	[000 – 000 ... 999-999]
Muting unit FMC-Tina	44 799 12 408341-003	[000 – 000 ... 999-999]
Non-contact safety sensor Eden including locking function Magne 2A, 2B, 2AX, 2BX	44 799 12 408341-003	[000 – 000 ... 999-999]

Certification body

TÜV NORD CERT GmbH  
Langemarckstrasse 20  
45141 Essen  
Germany

Used harmonized standards

EN ISO 12100-1:2010, EN ISO 13849-1:2008, EN ISO 13849-2:2008,  
EN 62061:2005, EN 60204-1:2006+A1:2009, EN 60664-1:2007, EN 61000-6-2:2005,  
EN 61000-6-4:2007, EN 60947-5-1:2004, EN 1088+A2:2008

Other used standards

EN 61508:2010



Jesper Kristensson  
PRU Manager  
Kungsbacka 2012-05-31

[www.abb.com](http://www.abb.com)  
[www.jokabsafety.com](http://www.jokabsafety.com)

Original

ABB JOKAB SAFETY Varlbergsvägen 11, SE-434 39 Kungsbacka, Sweden

[www.abb.com/jokabsafety](http://www.abb.com/jokabsafety)