

DCS Thyristor Power Converters
for DC Drive Systems
22 to 9750 / 19500 A

Installation Manual
DCA 500, DCA 600 Enclosed Converters



How to use the DCA Documentation System

The matrix below indicates all available product documentation and its corresponding order numbers on its left columns as well as all existing DC Drive systems on its top rows. System descriptions, Technical data and Operating instructions (as far as they are available for the corresponding drive) are the basic documents and will be delivered together with each drive. All other documentation has to be ordered separately.

DC drive systems			System Drive						Standard Drive						Rebuild
			Cabinet			Module			Cabinet			Module			
			DCA 600	DCA 620		DCS/DCF 600 MultiDrive	DCS 600 CraneDrive		DCA 500 / DCA 520	DCS 500 Easy Drive	DCS 400 Easy Drive	DCS 400	DCS/DCF 500B	DCE 400	
Product documentation															
System description			Language	Volume											
3ADW000066			EN, DE,FR	II D							x	x		x	
3ADW000072			EN, DE	II F	x	x			x						
3ADW000121 ①			EN	II F1	x	x									
3ADW000095 (Manual) ②			EN,DE,FR,IT,SP	II K							x		x		
3ADW000139			EN	II F	x				x					x	
3ADW000071 (Flyer)			EN, DE							x					
3ADW000152			EN, DE,FR,IT,SP											x	
3ADW000173 (Flyer)			EN							x					
Technical Data			Language	Volume											
3ADW000165			EN	III				x	x				x		
Operating Instructions			Language	Volume											
3ADW000055			EN,DE,FR,SP	IV A									x		
3ADW000080			EN, DE	IV F	x	x			x						
3ADW000091 (Installation)			EN, DE	IV F1	x	x					x				
Software description			Language	Volume											
3ADW000078			EN	V D1							x	x		x	
3ADW000076			EN	V F	x	x			x						
3AST000953 ③			EN		x					x					
Tools			Language	Volume											
3AFE61178775 CMT/DCS500			EN	-							x	x		x	
EN 5926915-1 GAD			EN	-							x	x			
3ADW000048 (Application blocks)			EN	V A2							x	x		x	
3AFY61296123 Drive Window			EN	-	x	x			x	x					
Service Instructions			Language	Volume											
3ADW000093			EN, DE	VI A	x	x			x	x			x		
3ADW000131			EN	VI K							x			x	
Fieldbus			Language	Volume											
3ADW000086			EN	-							x	x		x	
3ADW000097			EN	-	x	x			x	x					
Others			Language	Volume											
3ADW000115 12-Pulse operation			EN	VIII F2	x				x						
3ADW000092 Rebuild manual			EN	XI H1					x						
3ADW000128 Paralleling DCS Conv.			EN	VIII D1	x				x				x		
3ADW000040 12-Puls operation			EN, DE	VIII A2						x				x	

available only for: DCS 500B / 600 drive systems

Status: 13.March.2003

- ① Covers information of Technical data
- ② Covers information of Technical data, Operating Instructions, Software Description
- ③ Covers information of Operating Instructions, Software Description

DCS Thyristor Power Converters
for DC Drive Systems
22 to 9750 / 19500 A

Installation Manual
DCA 500, DCA 600 Enclosed Converters

CODE: 3ADW 000 091 R0301 REV C

EFFECTIVE: 15.01.2003

SUPERSEDES: REV B- 26.11.1998

Safety Instructions

Attention

The manual *Safety and Operating Instructions for drive converters* (3ADW 000 033) has to be followed strictly.

Overview

This chapter contains safety instructions which must be complied with during installation, operation and maintenance of the power converters series **DCS 500B or DCS 600**. If these instructions are not complied with, this may result in injuries (perhaps even with fatal) or in damage to the power converter, the motor and the driven machine. Before starting with any work whatsoever at or with this unit, you must read the information given in this chapter.

Warnings

Warnings provide information on states which if the specified procedure for the state concerned is not meticulously complied with may result in a serious error, in major damage to the unit, in injury to persons and even in death. They are identified by the following symbols:



Danger: High Voltage! This symbol warns you of high voltages which may result in injuries to persons and/or damage to equipment. Where appropriate, the text printed adjacent to this symbol describes how risks of this kind may be avoided.

- All electrical installation and maintenance work on the thyristor power converter must be carried out by properly qualified staff who have been thoroughly trained in electrical engineering.
- The thyristor power converter and its adjacent units must be properly earthed by qualified professionals.
- You must NEVER perform any work on the thyristor power converter while it is still switched on. First switch the unit off, use a measuring instrument to make absolutely sure that the power converter has really been de-energized, and only then you may start with the work concerned.
- Due to external control circuits, there may be dangerously high voltages present at the thyristor power converter even after the line voltage has been switched off. So always work at the unit with appropriate caution! Non-compliance with these instructions may result in injury (or even death!).



General warning: this symbol warns you of non-electrical risks and dangers which may result in serious or even fatal injury to persons and/or in damage to equipment. Where appropriate, the text printed adjacent to this symbol describes how risks of this kind may be avoided.

- When thyristor power converters are in use, the electric motors, power transmission elements and the driven machines are working in an extended operating range, which means they have to cope with a relatively high loading.
- You should have made sure that all units, devices and appliances used are actually suitable for this higher loading.
- If you have to operate the thyristor power converter at a rated motor voltage and/or a rated motor current significantly below the figures stated in the thyristor power converter's output data, you must take appropriate precautionary measures to protect the unit against overspeed, overload, breakage, etc., by modifying the software or hardware appropriately. For insulation testing, you must disconnect all cables from the thyristor power converter. You should avoid operating your unit at values other than the rated data. Non-compliance with these instructions may cause lasting damage to the thyristor power converter.
- The thyristor power converter possesses a number of automatic reset functions. When these functions are executed, the unit will be reset after an error and will then resume operation. These functions should not be used if other units and devices are not suitable for an operating mode of this kind, or if their use might entail dangerous situations.



Warning of electrostatic discharge:

this symbol warns you against electrostatic discharges which may damage the unit. Where appropriate, the text printed next to this symbol describes how a risk of this kind may be avoided.

Notes

Notes supply information on states requiring particular attention, or indicate that additional information is available on a specific topic. For this purpose, the following symbols are used:

CAUTION! **Cautions** are designed to draw your attention to a particular state of affairs.

Note A **note** contains or refers you to additional information available on the particular topic concerned.

Mains connection

You can use a switch disconnecter (with fuses) in the power supply of the thyristor power converter to disconnect the electrical components of the unit from the power supply for installation and maintenance work. The type of disconnecter used must be a switch disconnecter as per EN 60947-3, Class B, so as to comply with EU regulations, or a circuit-breaker type which switches off the load circuit by means of an auxiliary contact causing the breaker's main contacts to open. The mains disconnecter must be locked in its "OPEN" position during any installation and maintenance work.

EMERGENCY STOP buttons

EMERGENCY STOP buttons must be installed at each control desk and at all other control panels requiring an emergency stop function. Pressing the STOP button on the CDP 31x control panel of the thyristor power converter will neither cause an emergency motor stop, nor will the drive be disconnected from any dangerous potential.

To avoid unintentional operating states, or to shut the unit down in case of any imminent danger according to the standards in the safety instructions it is **not** sufficient to **merely** shut down the drive via signals "RUN", "drive OFF" or "Emergency Stop" respectively "control panel" or "PC tool".

Intended use

The operating instructions cannot take into consideration every possible case of configuration, operation or maintenance. Thus, they mainly give such advice only, which is required by qualified personnel for normal operation of the machines and devices in industrial installations.

If in special cases the electrical machines and devices are intended for use in non-industrial installations - which may require stricter safety regulations (e.g. protection against contact by children or similar) -, these additional safety measures for the installation must be provided by the customer during assembly.

Safety Instructions

EMC requirements for plants and machines in the EU

The following standard must be complied with to meet the EMC requirements for plants and machines in the EU:

For compliance with the protection objectives of the German EMC Act (EMVG) in systems and machines, the following EMC standards must be satisfied:

Product Standard EN 61800-3

EMC standard for drive systems (**PowerDriveSystem**), interference immunity and emissions in residential areas, enterprise zones with light industry and in industrial facilities.

This standard must be complied with in the EU for satisfying the EMC requirements for systems and machines!

In cases where the product standard is not applied, the generic standards EN 50081 and EN 50082 are sometimes adduced.

For emitted interference, the following apply:

EN 50081-1 Specialised basic standard for emissions in **light industry** can be satisfied with special features (mains filters, screened power cables) in the lower rating range.

EN 50081-2 Specialised basic standard for emissions in **industry**

For emitted interference, the following apply:

EN 50082-1 Specialised basic standard for interference immunity in **residential areas**

EN 50082-2 Specialised basic standard for interference immunity in **industry**. The EN 61000-6-2 standard replaces EN 50082-2. If this standard is satisfied, then the EN 50082-1 standard is automatically satisfied as well.

For more information see *System description DCS 500B* (3ADW 000066) and *System description DCS 600* (3ADW 000072).

Conformity Procedure



The conformity procedure is a matter of responsibility of the machine manufacturers or the plant builders and of ABB Automation Products corresponding to their share of the extension of the electrical equipment!

**Important instructions
for plants with line
filters**



Filter in a grounded line (earthed TN or TT network):

The filters are suitable for grounded lines only, for example in public European 400 V lines. According to EN 61800-3 filters are not needed in insulated industrial lines with own supply transformers. Furthermore they could cause safety risks in such floating lines (IT networks).

Earth fault detection:

Together filters (with internal discharging resistors), cables, converter and motor have a considerable capacity to ground which can cause an increased capacitive earth current. The tripping threshold of an earth fault detector which measures this current must be adapted to this higher value.

High voltage test:

Because of the capacitors of the line filter the high voltage test has to be done with DC voltage to protect the components.

Table of Contents

Safety Instructions

Attention	i
Overview	i
Warnings	i
Notes	i
Mains connection	iii
EMERGENCY STOP buttons	iii
Intended use	iii

EMC Standards

EMC requirements for plants and machines in the EU	v
Conformity Procedure	v
Important instructions for plants with line filters	vi

Chapter 1 – Introduction

General	1-1
Contents of this Manual	1-1
Associated Publications	1-1
Inquiries	1-1

Chapter 2 – Mechanical Installation

Required Tools	2-1
Cabinet Construction	2-2
Moving of the Shipping Splits	2-3
Working Order of the Mechanical Installation	2-5
Fastening the Shipping Split to the Floor	2-6
Fastening Clamps 3AFE 64347683	2-6
Holes inside the Cabinet	2-7
Layout of bottom plate	2-9
Cable Conduit below the Cabinet	2-17
Vibration Dampers (Marine Versions)	2-18
Joining the Shipping Splits	2-19
Working Order	2-19
Connecting the AC Busbar and the PE Busbar	2-21
Filter and Ventilation	2-22
Filter	2-22
Air Duct Outlet for Cabinets with C4 Modules	2-23

Chapter 3 – Electrical Installation

Insulation Checks	3-2
Mains Fuses	3-2
Cabling Instructions	3-3
Power Cables	3-3
Control / Signal Cables	3-3
Co-axial Cables	3-4
Relay Cable	3-4

Table of Contents

Control Panel Cable	3-4
Optical Cables	3-4
Connection example in accordance with EMC	3-5
Cross-sectional areas - Tightening torques	3-6
Cable Connections	3-10
Mains Cable Connection	3-10
Low Power Supply	3-10
High Power Supply	3-11
Motor Cable Connection	3-12
Cable Tray or Bus Duct	3-12
Mechanical Cable Connections	3-12
Location of Cable Connections within the Cabinet	3-13
Motor Cable Connection	3-13
Conductive Sleeves	3-13
Cable Entry	3-13
Control Cable Connection	3-14
EMC Grounding at the Cable Entry	3-14
Installation of Optional Modules (only for DCA 600)	3-18
Fieldbus adapter modules	3-19
Fiber optic configurations	3-19

Chapter 4 – Installation Checklist

Installation Checklist	4-1
------------------------------	-----

Chapter 5 – Preventive Maintenance

Recommended regular maintenance	5-1
Air Filters	5-1
Cooling air pressure switch in converter modules type C4	5-1
Fan	5-1
Heatsink	5-1
Internal high current connections in converters type C4	5-2
Relays and electrical connections	5-2

Chapter 1 – Introduction

General

This Installation Manual about **DCA 500, DCA 600 Enclosed Converters** is to be used together with the corresponding manuals *System Description, Technical Data* and *Operating Instructions*.

Note: If it is not mentioned explicitly all details given in this Installation Manual will be valid for **DCA 500, DCA 600 Enclosed Converters**.

Study the Safety Instructions / EMC Standards of this manual carefully before installing the **DCA 500, DCA 600 Enclosed Converters**.

Note: For additional information, refer to below mentioned manuals.

We expect that you have a basic knowledge of physical and electrical fundamentals, electrical wiring practices, electrical components and electrical schematic symbols.

Contents of this Manual

Safety Instructions / EMC Standards

In Chapter 2, all mechanical information concerning the installation of the DC enclosed converters is provided. In this chapter, details such as moving the shipping splits, joining the units together, joining the busbars and fastening the cabinets to the floor are given.

Chapter 3 discusses the electrical installation.

Chapter 4 introduces preventive maintenance.

Associated Publications

The manuals *Operating Instructions DCS 500B/DCS 600* include Safety Instructions to be observed during commissioning, operating or servicing as well as all information required for start-up.

The manuals *System Description DCS 500B/DCS 600* and *Technical Data DCS 500B/DCS 600* include required information concerning the ratings, fuses, cooling requirements, power losses, etc.

Manual *Technical Guide (3ADW 000 163)*.

Inquiries

For inquiries about the product please address your local ABB representative, quoting type code and serial number of the unit. If the local ABB representative is not available, inquiries should be addressed to ABB Automation Products GmbH, Lampertheim, Germany.

Chapter 2 – Mechanical Installation

This chapter provides instructions for moving shipping splits (= complete drive systems divided into parts before shipping), fastening them to the floor and joining them together.

See manuals *System description* and *Technical Data* for allowed operating conditions of the DC thyristor power converters. For sufficient room around the unit see *Figure 2-8*. Room around the unit is required to enable cooling air flow, service and maintenance. Proper mechanical installation is an important element for a trouble free installation and should be followed closely.

The DC thyristor power converter cabinets should be installed in an upright vertical position.

The floor the unit is installed on should be of non-flammable material, as smooth as possible, and strong enough to support the weight of the unit. The floor flatness must be checked with a water level before fastening the cabinets into their final position. The maximum allowed deviation of the surface level must be ≤ 5 mm for every 3 m of length. The installation area should be levelled, since the cabinet is not equipped with adjustable feet.

The wall behind the unit should be of non-flammable material.

Required Tools

The tools required for moving the shipping splits to their final position, fastening to the floor and tightening the connections are listed below:

- 1.) Iron bar and roller tubes or similar tools to move the shipping splits;
- 2.) Pozidrive and Torx (2.5-6 mm) screwdrivers for the tightening of the frame screws;
- 3.) Torque wrench;
- 4.) A 17/19 mm wrench set for tightening the AC horizontal busbars between the shipping splits;
- 5.) A 17 mm wrench set for tightening the PE busbars between shipping splits.

Cabinet Construction



Figure 2-1 DCA 500 / DCA 600 enclosed converters

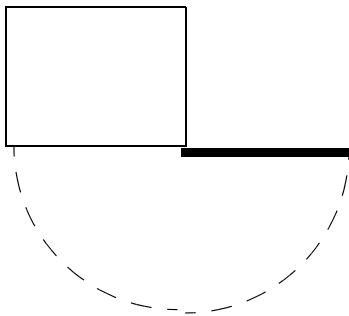

Figure 2-2 Cabinet door opening

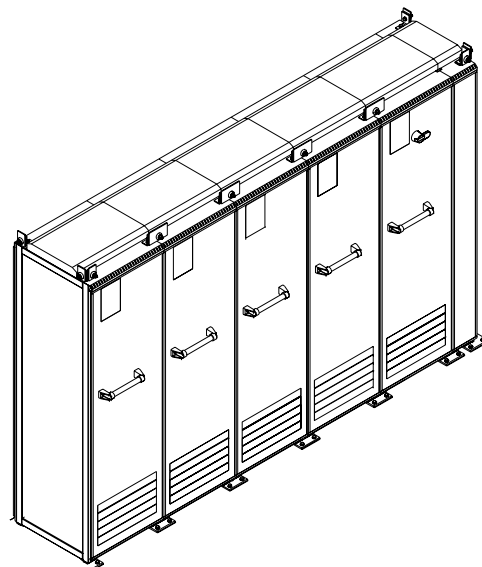
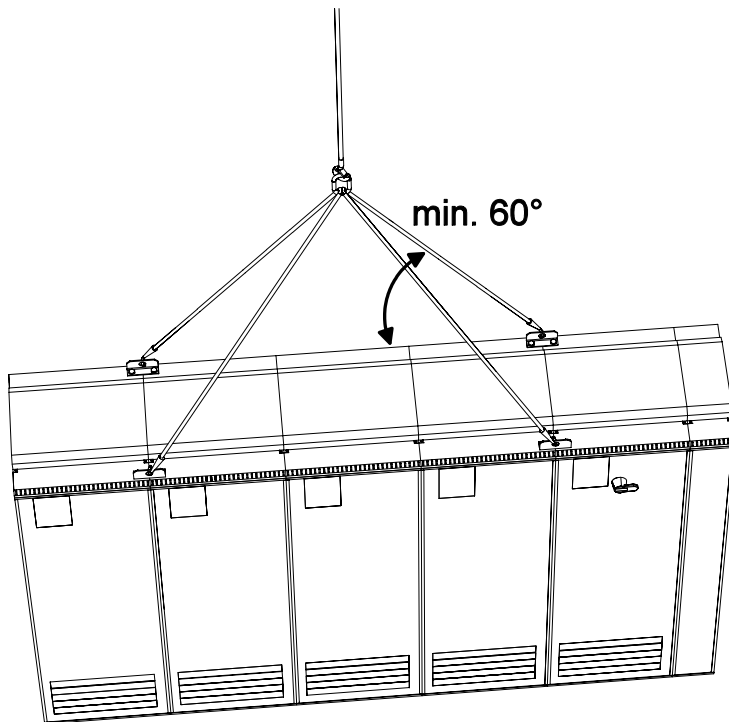

Figure 2-3 Marine applications including handles and locking devices for open doors

Moving of the Shipping Splits



Use the steel lifting lugs attached to the top of the cabinets. Insert the lifting ropes or slings into the holes of the lifting lugs.

The lifting lugs can be removed (but not mandatory) once the cabinets are in their final position. **If the lifting lug is removed, the bolts for each lug must be refastened to maintain the degree of protection of the cabinet.**

Notes: Maximum length of one shipping split is 3.4 m.
If required, the double roofs of all cabinets can be removed while placing the shipping split on its final position (see *Working order of Mechanical Installation* within this Chapter).

Figure 2-4 By crane

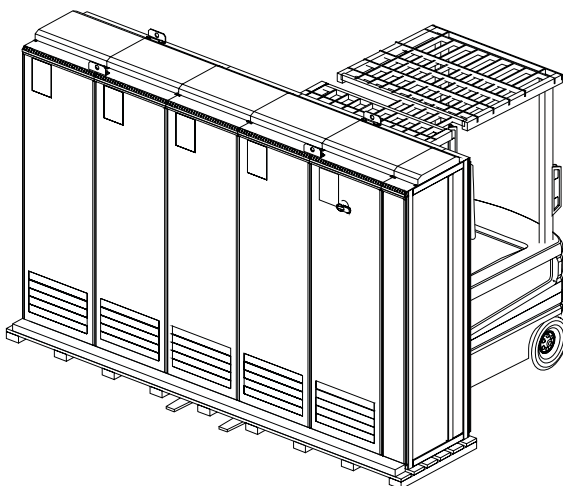

The center of gravity may be quite high, therefore caution should be used when transporting the shipping splits. Tilting of the cabinets must be avoided.

Moving of the shipping splits only with the cabinets in upright position.

Note: The shipping split has to be placed on a suitable pallet for transportation by forklift!

Figure 2-5 By fork-lift

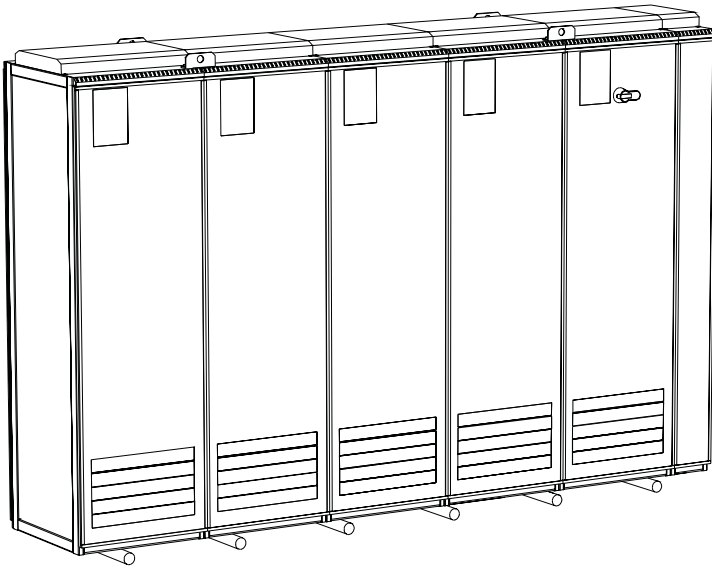

Remove the bottom wooden frame which is part of the shipment.

Place the shipping split on the rollers and move the unit carefully until it is close to its final position.

Remove the rollers by lifting the shipping split using a crane or fork-lift as described above.

Figure 2-6 By rollers (Not allowed for marine versions)

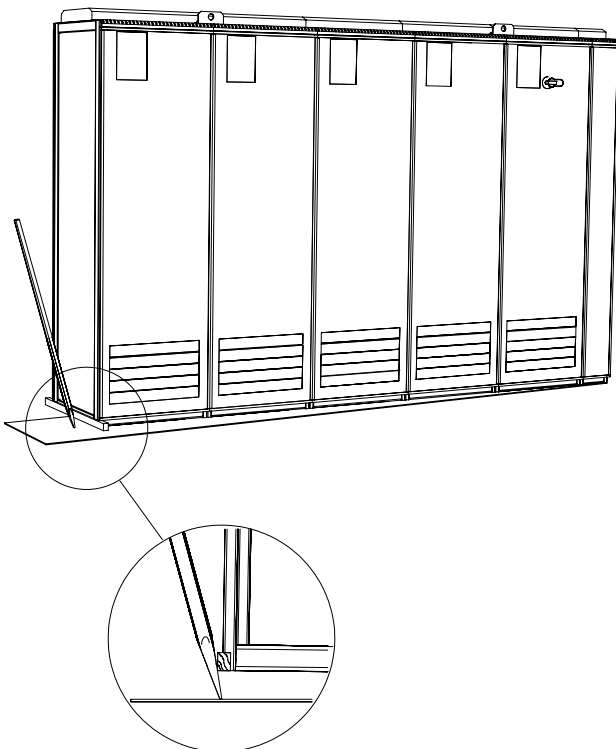

The cabinets can be moved to their final position by using an iron bar and a piece of wood at the bottom edge of the cabinet. Take care and place the piece of wood properly to prevent damage the cabinet frame.

Figure 2-7 Final placement of shipping split (Not allowed for marine versions)

Working Order of the Mechanical Installation

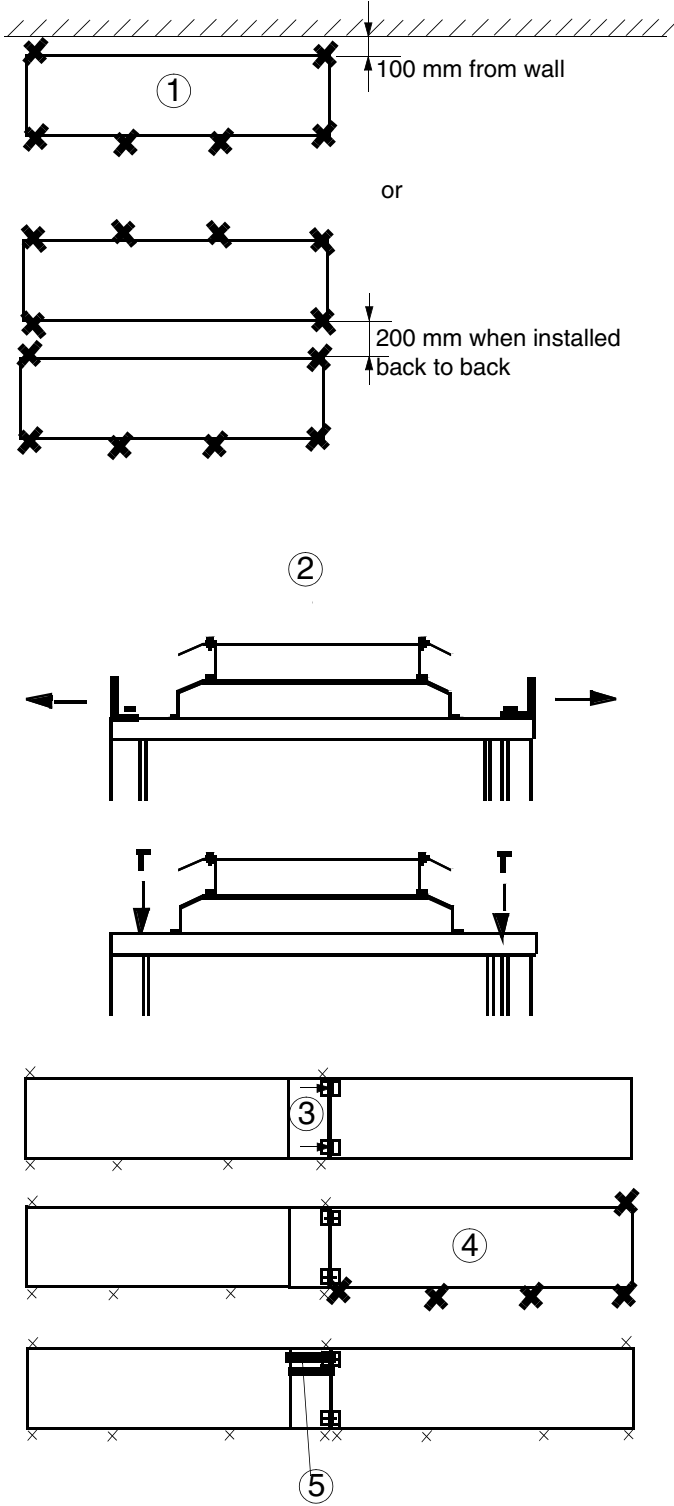

- ①. Fasten the first shipping split to the floor with fastening clamps or through the holes inside the cabinet. See section *Fastening the Shipping Split to the Floor*. In marine versions, fasten the first shipping split to the floor and roof/wall as described in section *Vibration Dampers (Marine Versions)*.
Note: Any height adjustment of the cabinets must be done before fastening the cabinets together. Height adjustment can be done by using metal shims between the bottom frame and floor.
- ②. Remove the lifting bars (if used) and the lifting lugs (only for marine applications). Refasten the original bolts or upper vibration dampers (only for marine applications) in order to maintain the degree of protection of the cabinet.
- ③. Fasten the first shipping split to the next shipping split. See section *Joining the shipping splits*. Each shipping split includes a 200 mm joining cabinet.
- ④. Fasten the second shipping split to the floor.
- ⑤. Connect the AC busbars and the PE busbar. See section *Connecting the AC Busbar and the PE Busbar*
- ⑥. Reinstall the roof if they have been removed. Attach each roof with 6 screws M6.

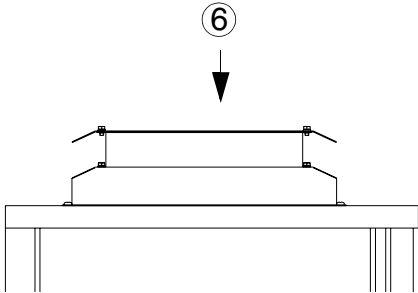

Figure 2-8 Working order installation

Fastening the Shipping Split to the Floor

Fastening the shipping split to the floor is especially important in installations subject to vibration or other movement.

Fastening Clamps 3AFE 64347683



Insert the clamp into the longitudinal hole in the edge of the cabinet's frame body and fasten it with a bolt to the floor. Allowed maximum distance between the fastening clamps is 800 mm

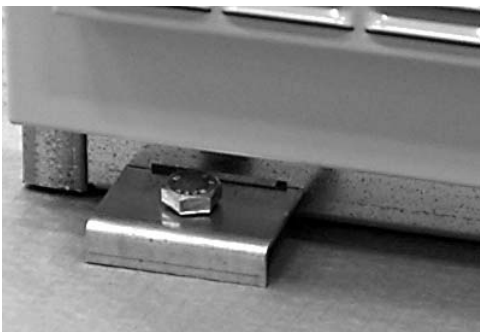

Fastening hole distances for the common cabinet are given in Table 2-1. Fastening bolt: M10 to M12 (3/8" to 1/2").

Cabinet Width (mm)	Hole Distance (mm)
200	
400	a: 250
600	a: 450
800	a: 650
1000	a: 350, b: 150, a: 350
1500	a: 350, b: 150, a: 350, b: 150, a: 350

Figure 2-9 Fastening clamp

Table 2-1 Fastening clamp hole distances

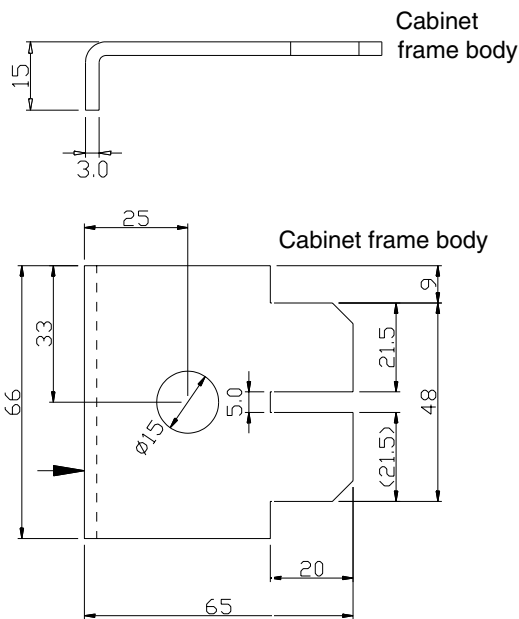
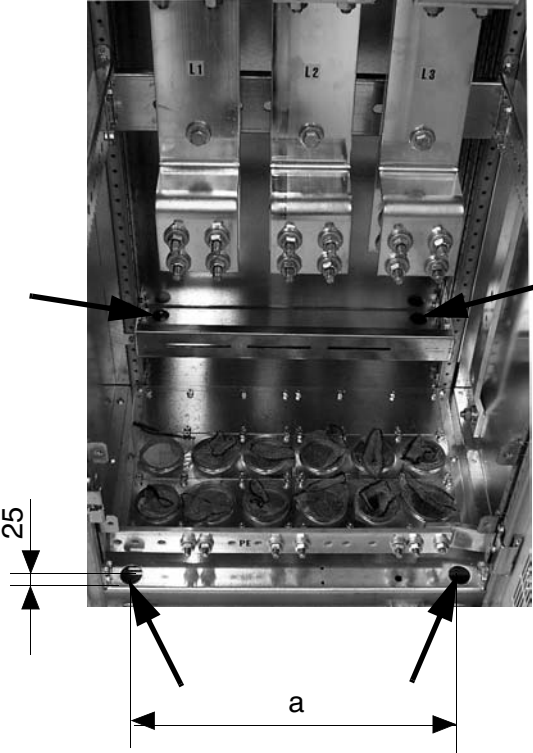

Figure 2-10 Dimensions of fastening clamp

Holes inside the Cabinet The cabinet can be fastened to the floor using the fastening holes inside the cabinet, if they are available and accessible. Allowed maximum distance between the fastening points is 800 mm.



Fastening holes inside the cabinet

Side plates of the cabinet: 15 mm
Back plate of the cabinet: 10 mm

Small gap between the 200 mm, 400 mm, 600 mm, 800 mm, 1000 mm and 1500 mm cabinets:

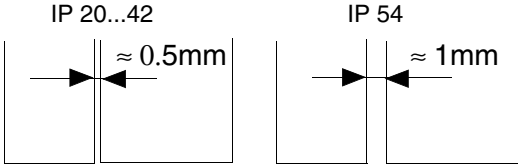

Figure 2-11 Fastening holes

Figure 2-12 Gap between cabinets

Fastening hole distances for the common cabinet are given in Table 2-2. Fastening bolt: M10 to M12 (3/8" to 1/2").

Cubicle Width (mm)	Hole Distance (mm)	
	Diagram	inner Ø 18.5 mm outer Ø 31 mm
200		a: 50
400		a: 250
600		a: 450
800		a: 650
1000		a: 350, b: 150, a: 350
1500		a: 350, b: 150, a: 350, b: 150, a: 350

Table 2-2 Hole distances

The bottom plate subassemblies/frames of most cabinets (layout see next pages) are equipped with mounting holes ($\varnothing 18.5$ mm) together with trough holes ($\varnothing 31$ mm).

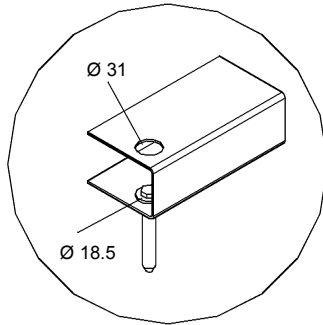

Figure 2-13 Mounting and through holes

Layout of bottom plate

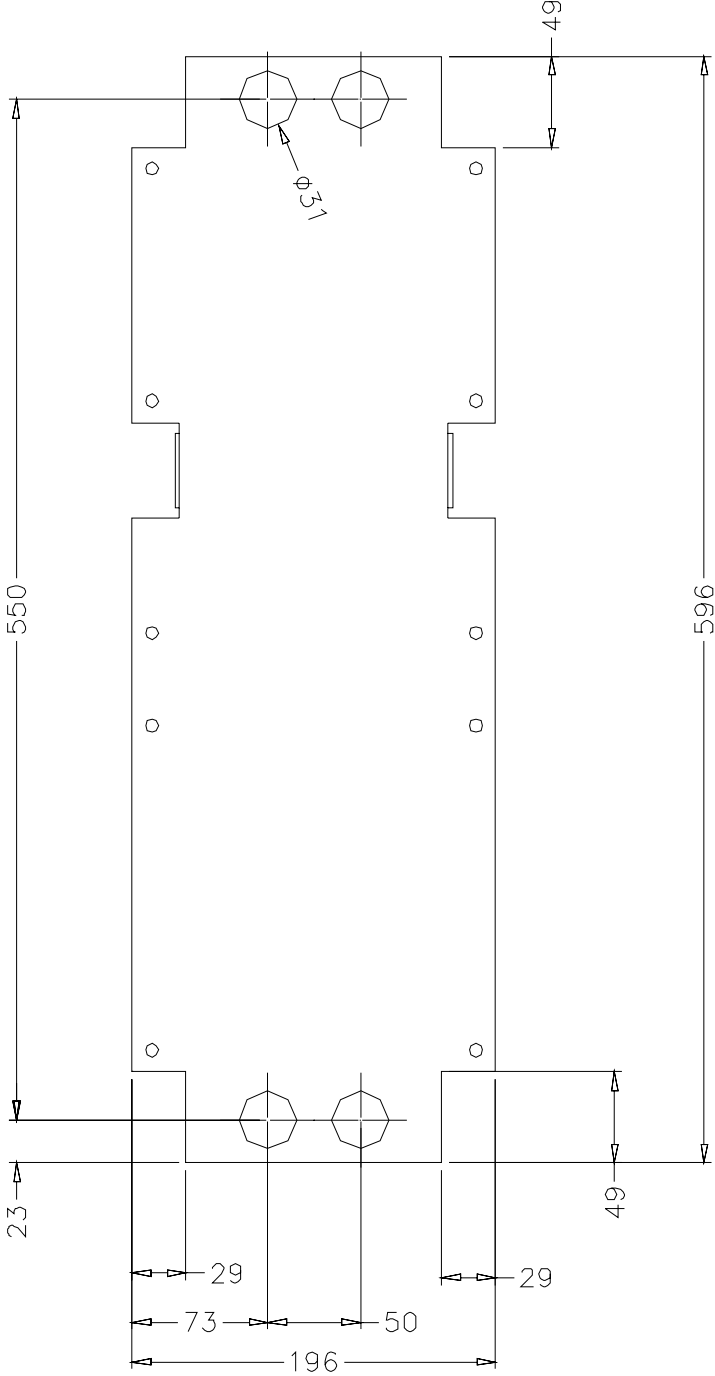

Figure 2-14 Cabinet 200 mm width, 600 mm depth

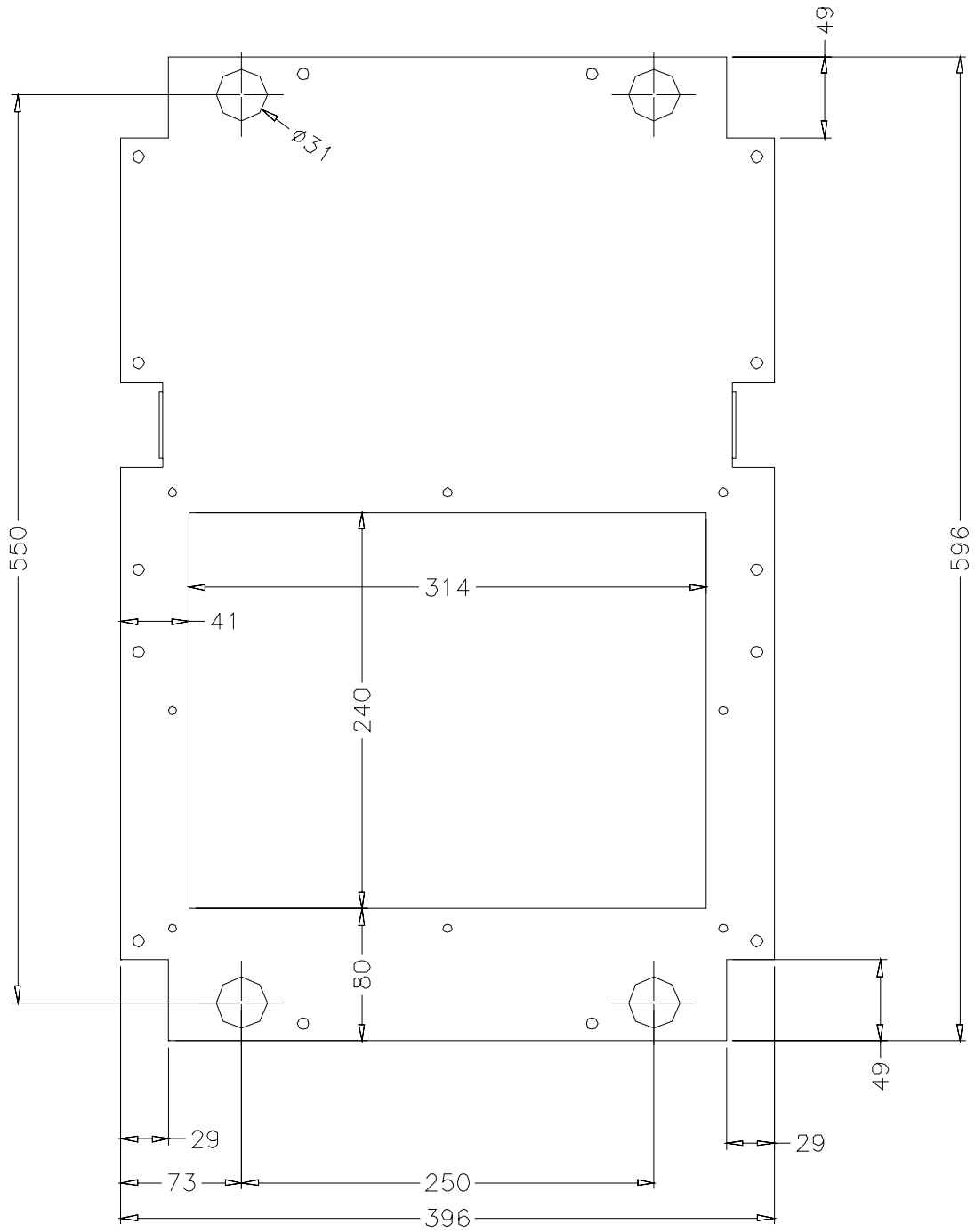

Figure 2-15 Cabinet 400 mm width, 600 mm depth

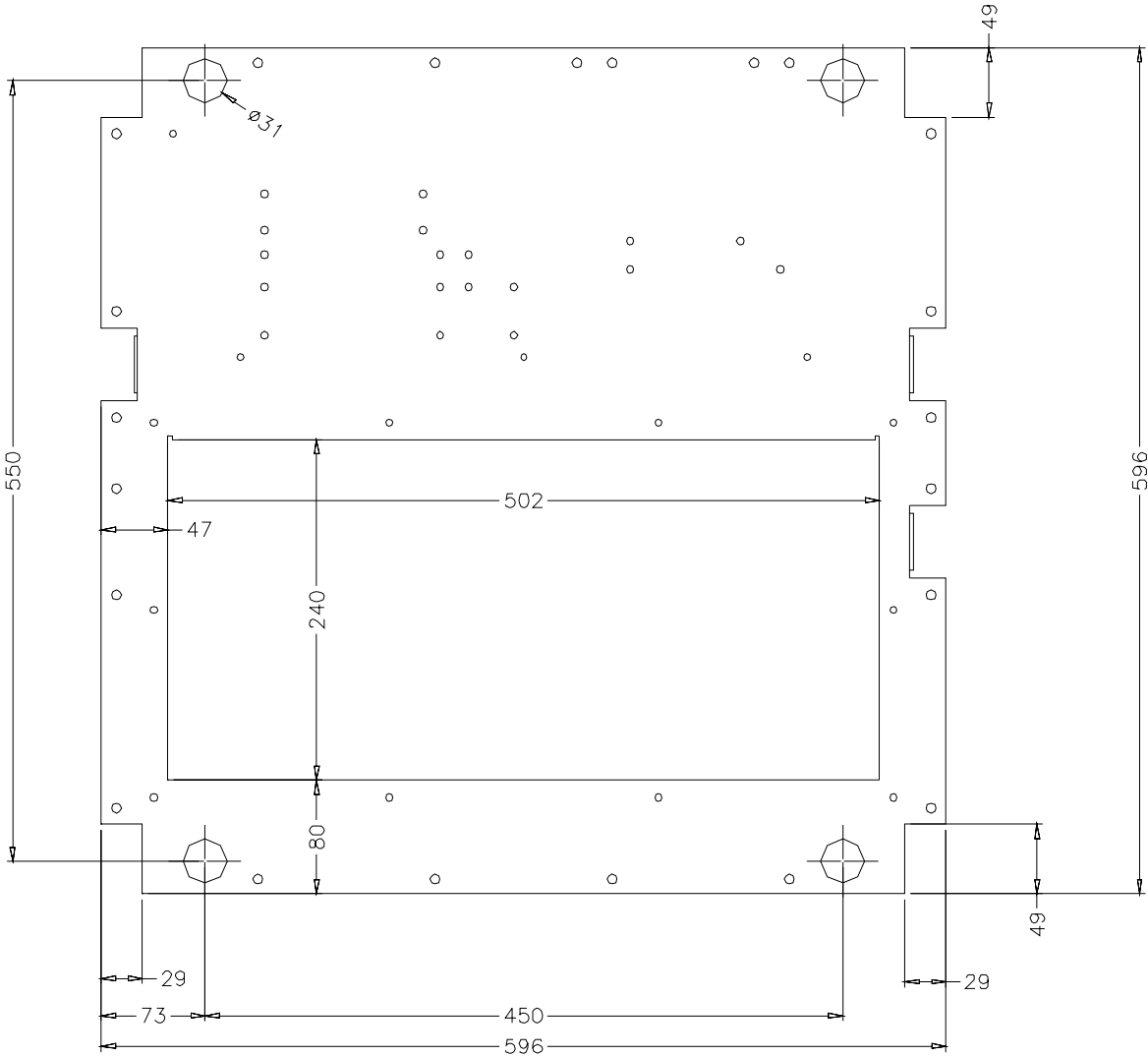

Figure 2-16 Cabinet and incoming 600 mm width, 600 mm depth and incoming

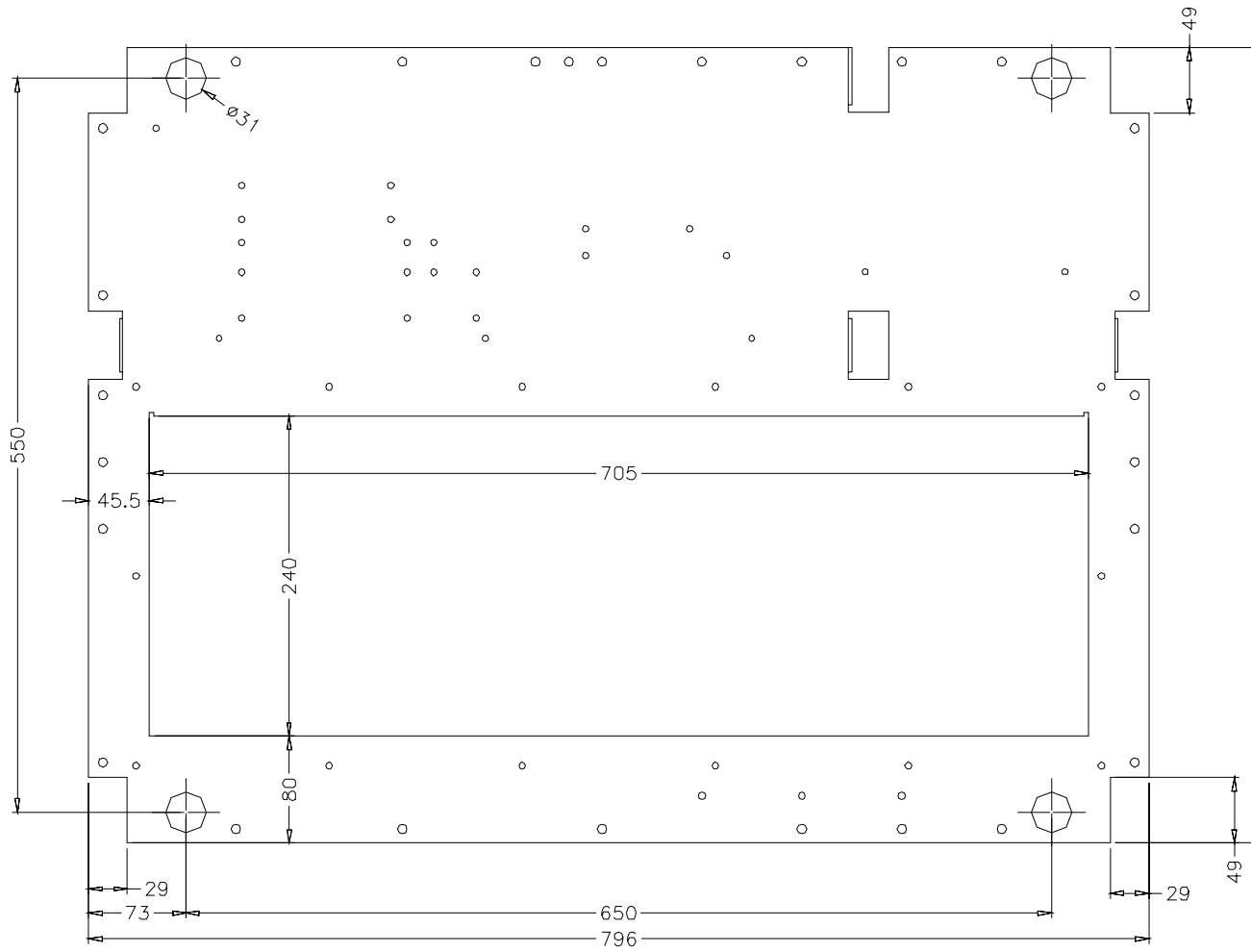

Figure 2-17 Cabinet and incoming 800 mm width, 600 mm depth

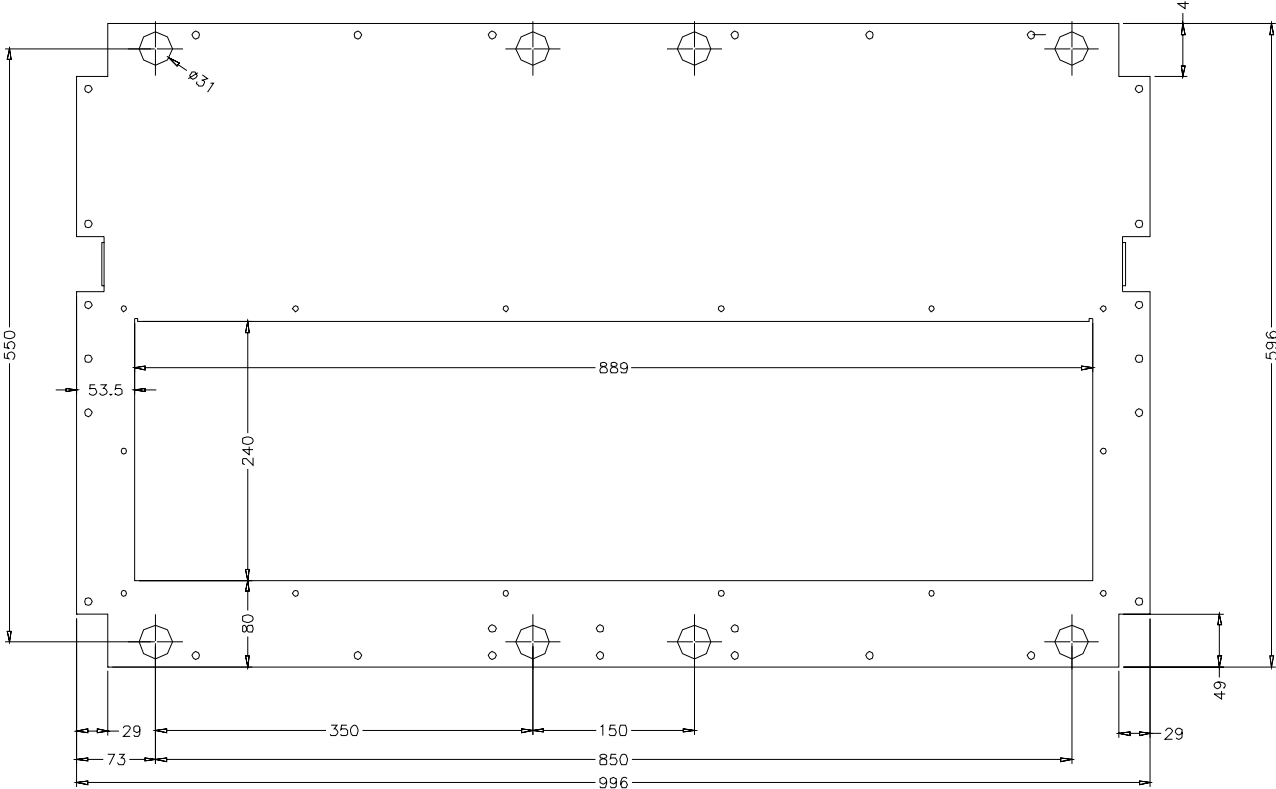

Figure 2-18 Incoming 1000 mm width, 600 mm depth

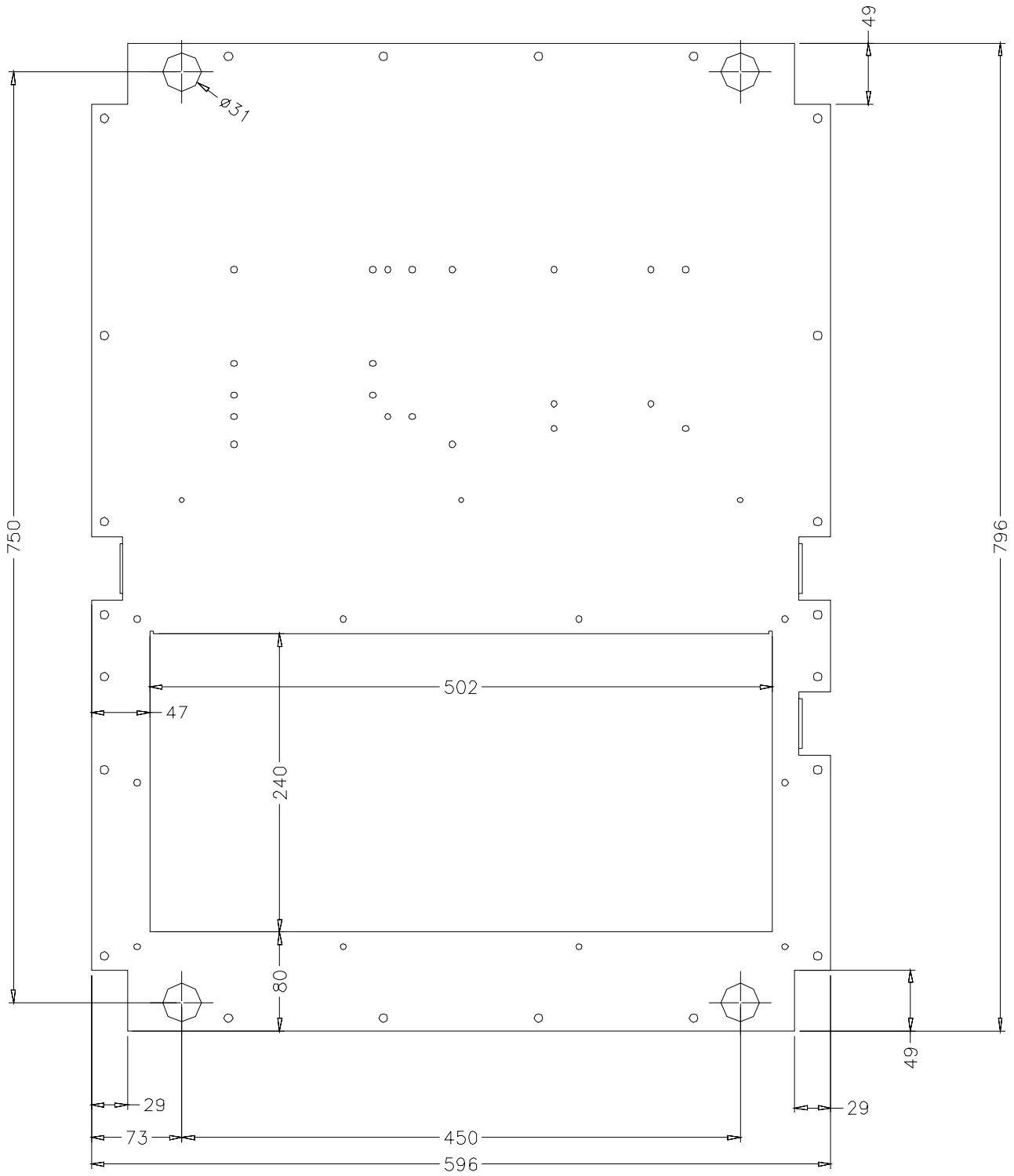

Figure 2-19 C4 control 600 mm width, 800 mm depth

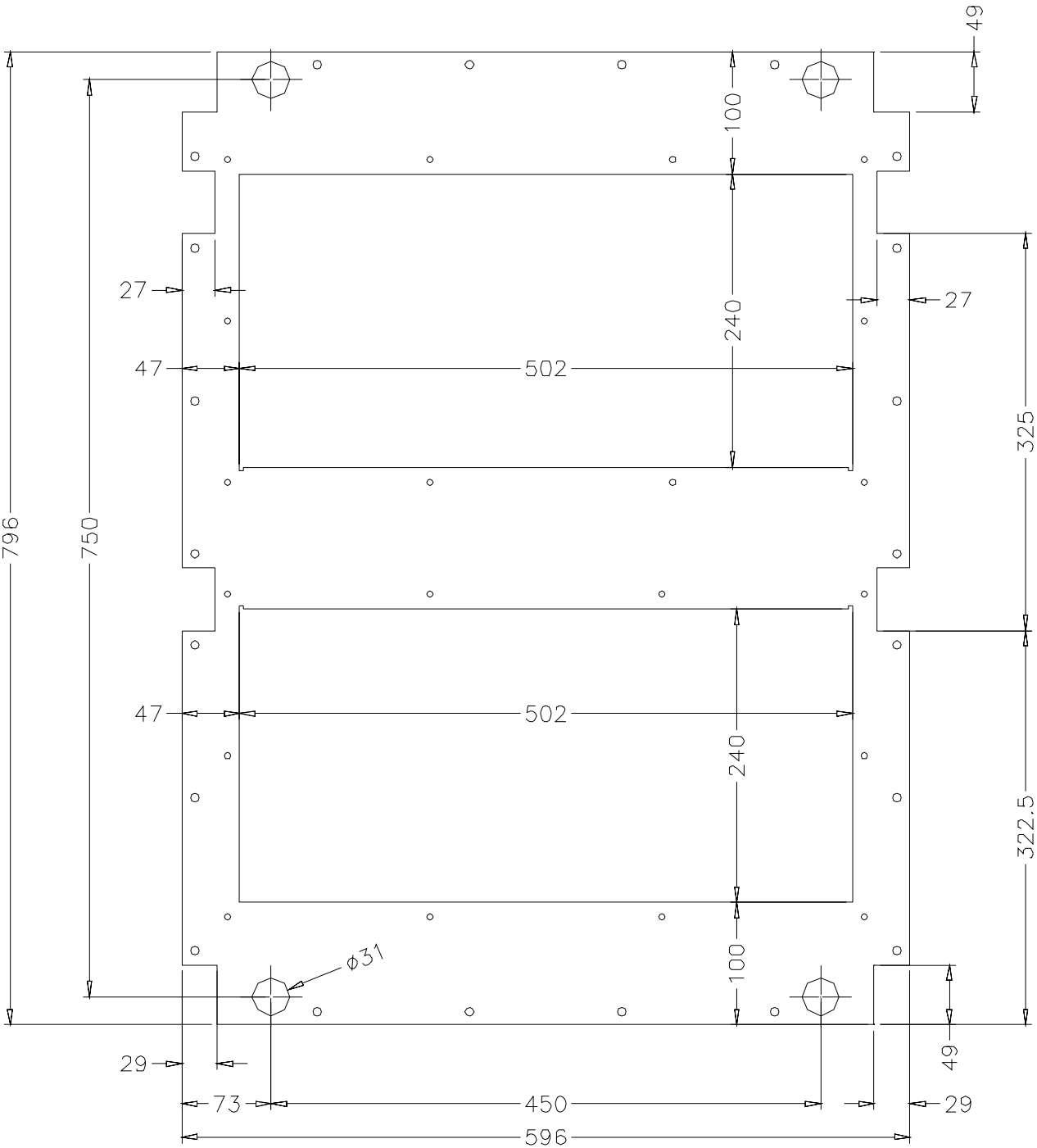

Figure 2-20 C4 incoming 600 mm width, 800 mm depth

Depending on the amount of cables several EMC-cable entry plates can be fastened over the cutout of the bottom plates. See also *chapter 3 section Cable Connections*.

Note: EMC-cable entry is only required for DCA 500 / DCA 600, when screened cables are used.

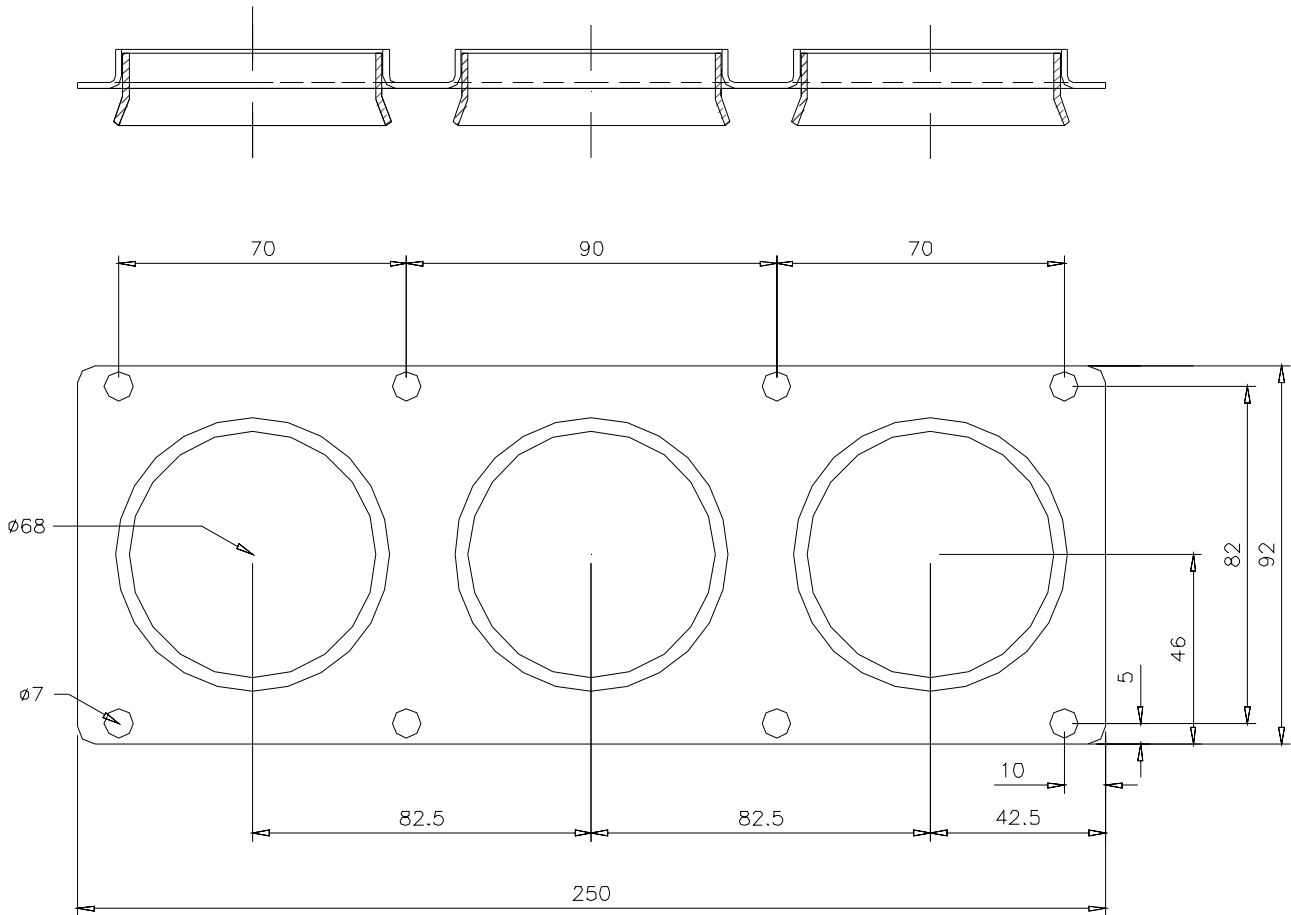

Figure 2-21 EMC-cable entry

Cable Conduit below the Cabinet

A cable conduit can be constructed below the 400 mm wide middle part of the cabinet. The cabinet weight has to be carried by the two 100 mm wide transverse sections of the floor.

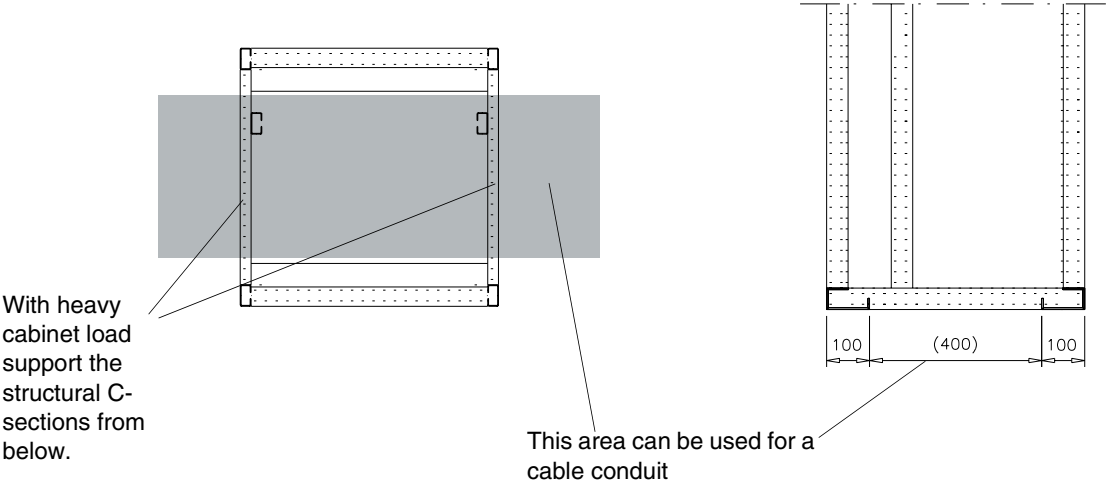

Figure 2-22 Top and side view

Prevent the cooling air flow from the cable conduit to the cabinet by using bottom plates. To ensure the degree of protection for the cabinet use the original bottom plates if delivered with the unit. User-defined cable entries take care of the degree of protection and fire protection.

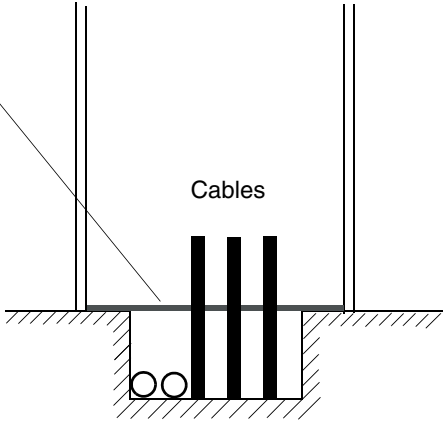

Figure 2-23 Protection

**Vibration Dampers
(Marine Versions)**

The shipping split must be fastened to the floor and roof/wall in marine versions as follows:

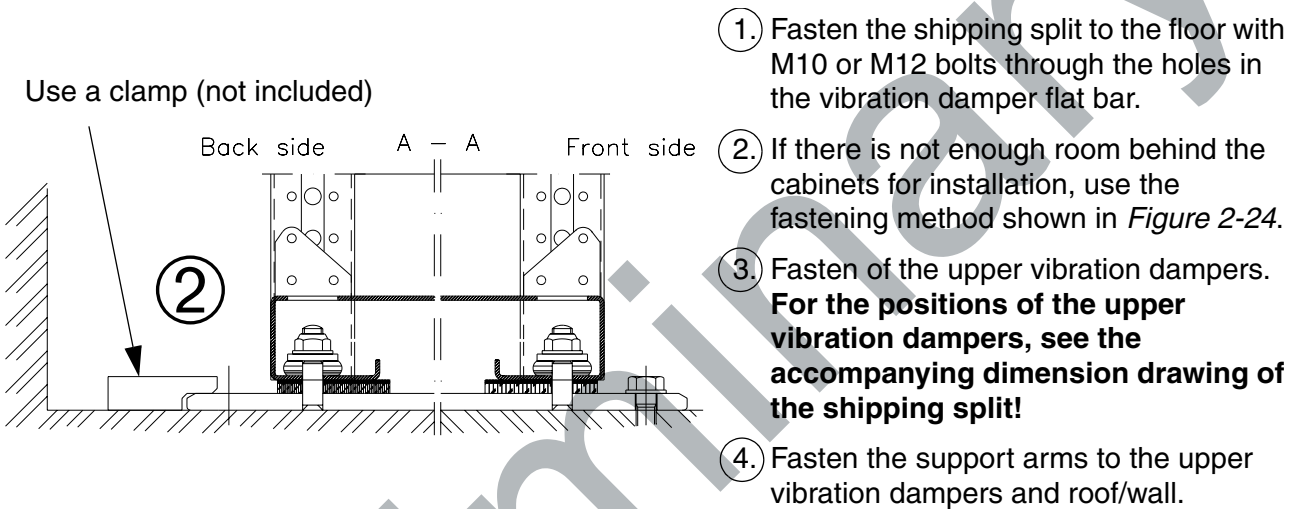

Figure 2-24 Mounting with a clamp

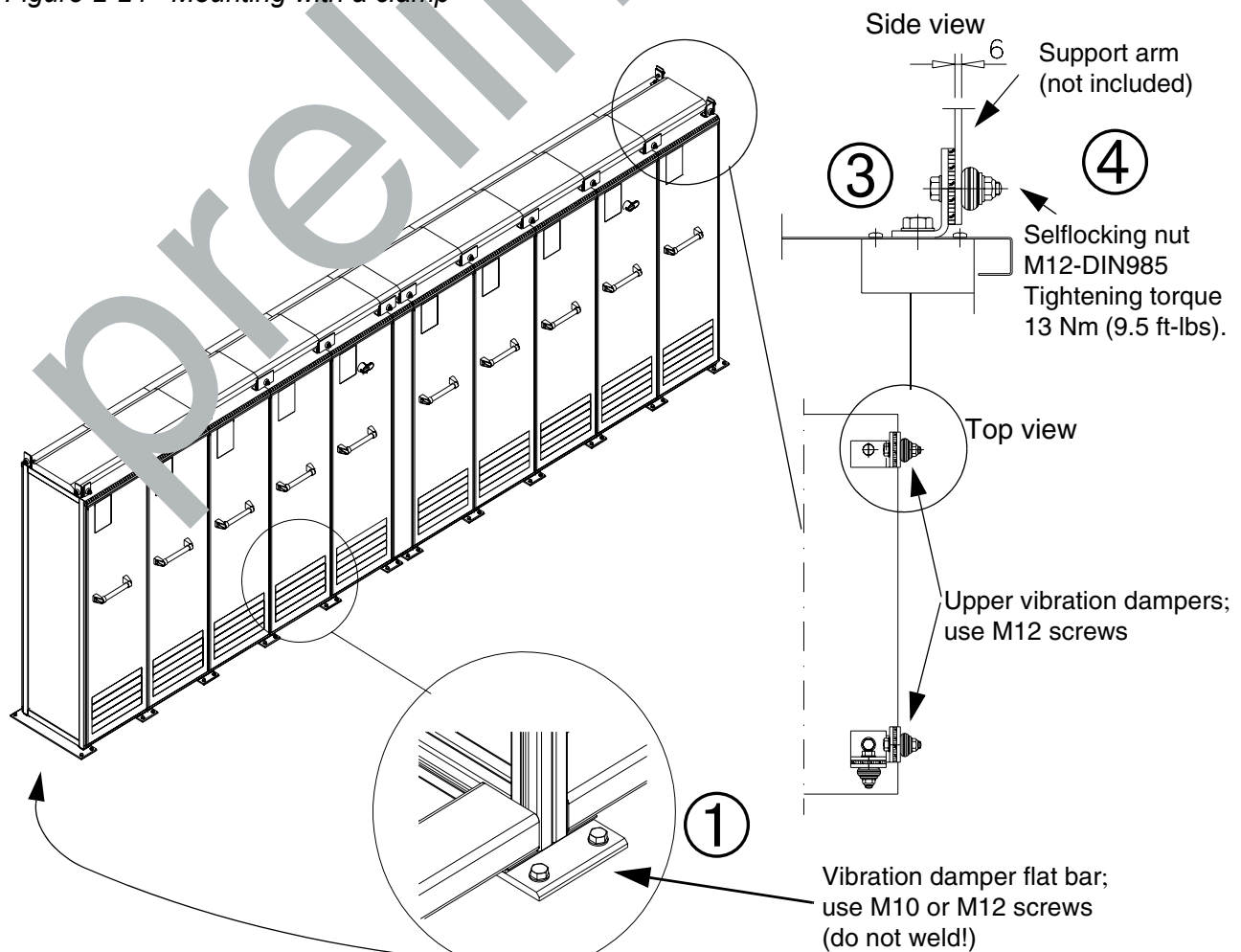

Figure 2-25 Vibration dampers details

Joining the Shipping Splits

Shipping splits are joined in the busbar joining cabinet. Special distance bolts (M6) for fastening the cabinets together are enclosed in a plastic bag inside a cabinet of the shipping split. The blind rivit nuts are already installed in the post.

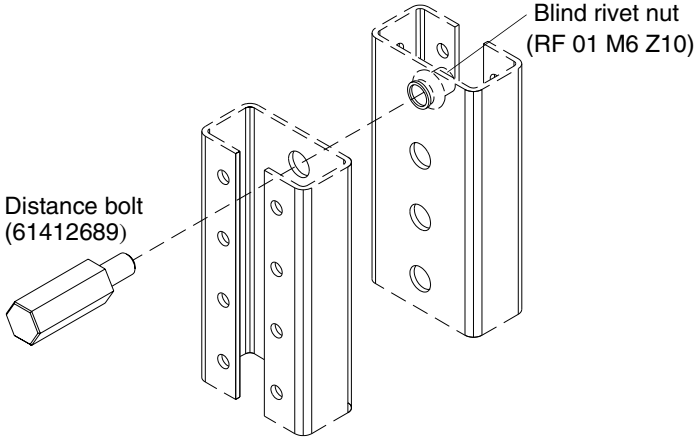

Figure 2-26 Detailed view

Working Order

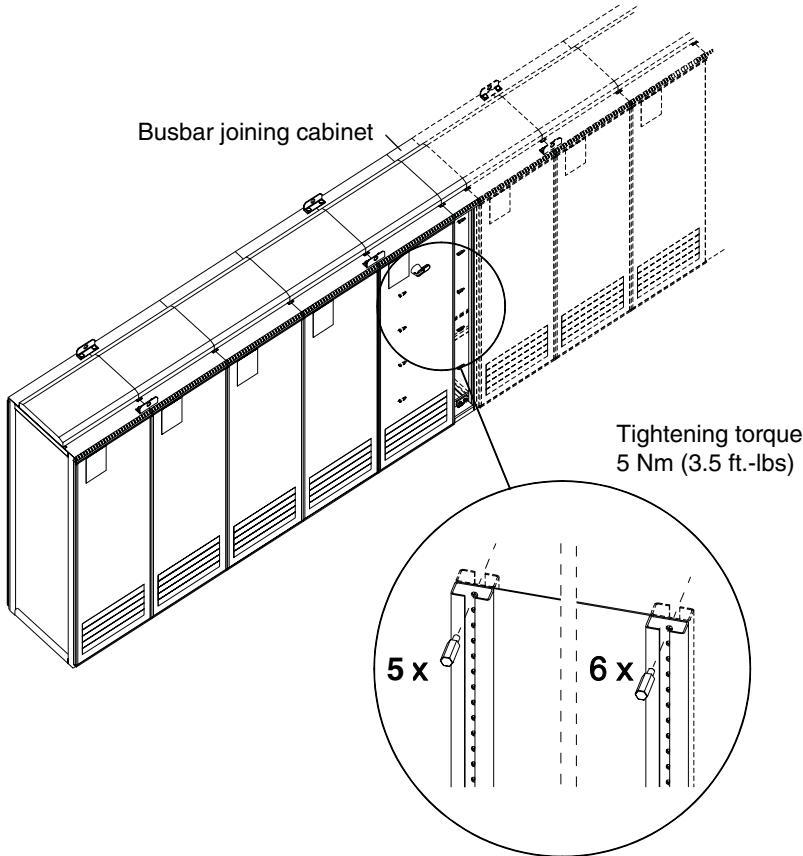

Figure 2-27 Overview

- 1.) Fasten the front post of the joining section with six distance bolts to the front frame post of the next cabinet.
- 2.) 200 mm wide joining cabinet: Remove the intermediate plate, hiding the back posts in the joining section.

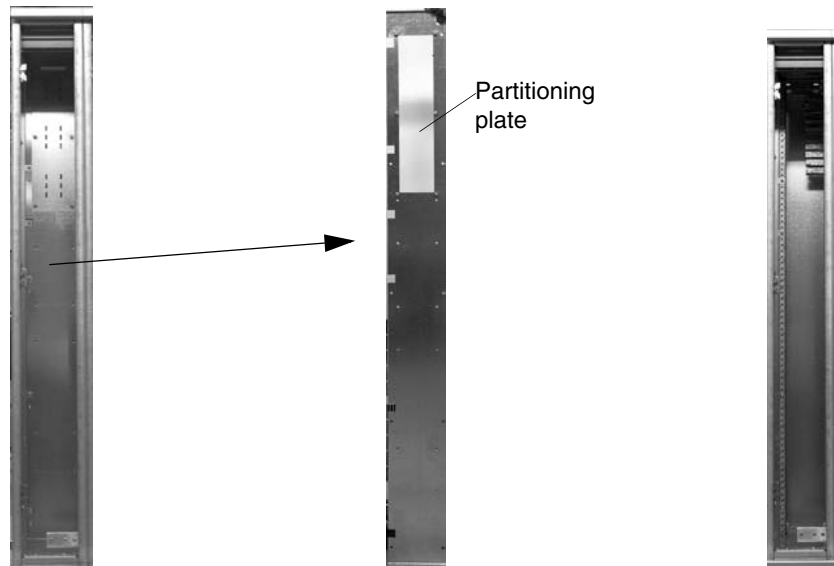

Figure 2-28 Busbar joining cabinet/Intermediate plate/Back posts accessible

- 3.) Fasten the back post of the joining cabinet with five screws (below the horizontal busbar joining part) to the post of the next cabinet.
- 4.) Remount the intermediate plate (and the partitioning plate(s) in the upper part after connecting the AC busbars.

Connecting the AC Busbar and the PE Busbar

The horizontal main AC busbars and the PE busbar are connected from the front of the 200 mm wide busbar joining cabinet. All necessary materials are located in the joining cabinet.

- 1.) Remove the intermediate plate located in the busbar joining cabinet.
- 2.) Unscrew the bolts of the joint pieces.
- 3.) Connect the busbars with the joint pieces (see *Figure 2-29*).
Remount the intermediate plate into its original position because of safety of personnel.
- 4.) Remount the intermediate plate into its original position because of safety of personnel.

AC busbar connection:

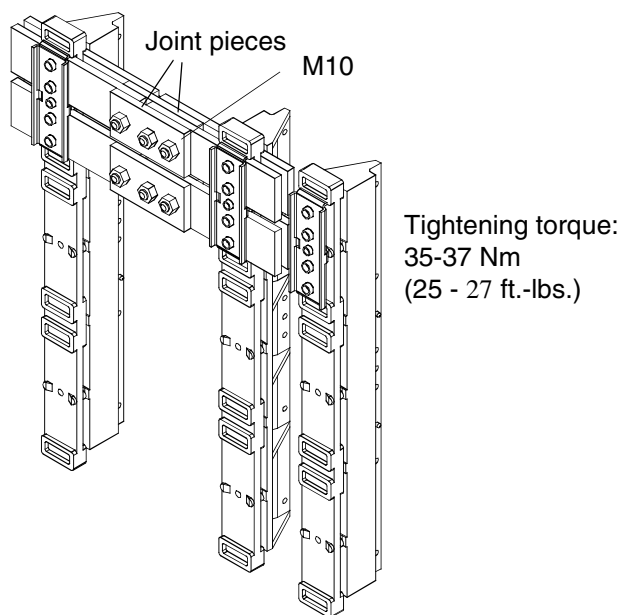

Figure 2-29 AC busbar

PE busbar connection:

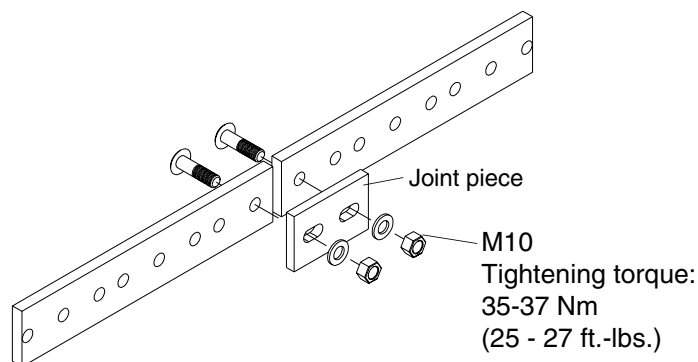

Figure 2-30 PE busbar

Filter and Ventilation

Filter Fit the filter into the ventilation cover. Attach the ventilation cover by means of mounting hooks to the door of the cabinet.

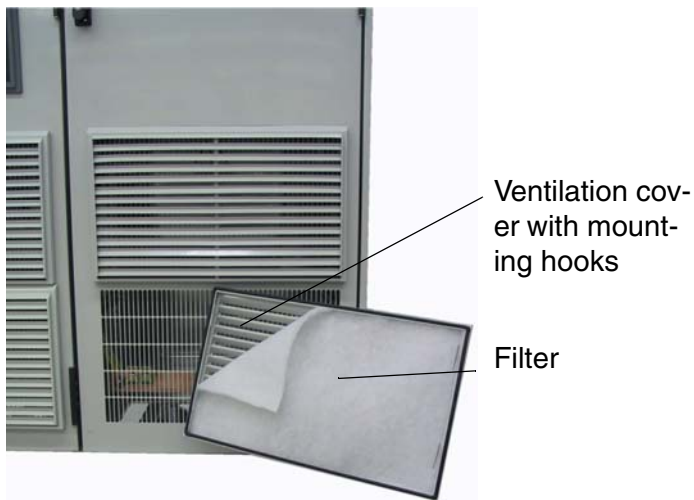

Figure 2-31 Door mounted filter

Replacement filters and brass screens can be ordered from ABB:

Cabinet width (mm)	Filter (Air-Tex G-150)	Brass screen
400	3AFE 1003 3616	3AFE 6152 5718
600	3AFE 1003 3721	3AFE 6152 5726
800	3ADV 262 037 P0001	3ADV 400 109 P0001
1000	3AFE 1003 4621	3AFE 6152 5734

Table 2-3 Order numbers for filters and screens

Air Duct Outlet for Cabinets with C4 Modules

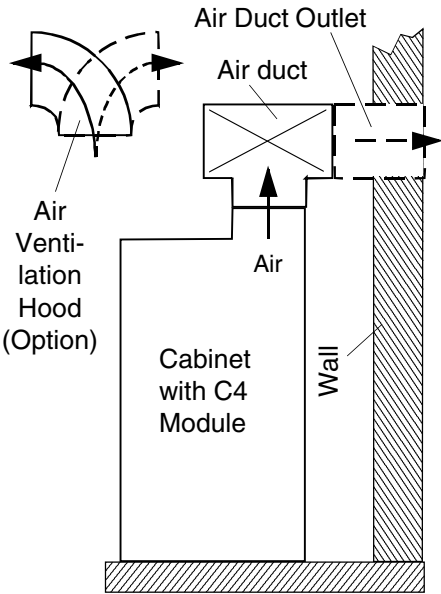

DC thyristor power converter modules **size C4** installed in cabinets DCA 500 / DCA 600 produce a considerable amount of power loss to be removed by air cooling. In most cases the switchroom is not capable to absorb the heated air. That is why cabinets with converter modules **size C4** are provided with an adapter for connection to an air duct (air duct to be supplied for by customer). In case there is no air duct, the option *Air Ventilation Hood* is required to meet protection class IP 21. This option can also be used for connection to an existing air duct outlet (solution indicated by dashed lines).

Figure 2-32 Air duct for C4 module

Chapter 3 – Electrical Installation



WARNING! The electrical installation described in this chapter should only be carried out by a qualified electrician. The **Safety Instructions** on the first pages of this manual must be followed. Negligence of these instructions can cause injury or death.

Attention: Additional information about this chapter especially regarding EMC can be found in the manual *Technical Guide* (3ADW000163).

Insulation Checks

Every DCA 500 / DCA 600 Enclosed Converter has been tested for insulation between main armature circuit and cabinet at the factory. Therefore there is no need to check the insulation of the unit again. When checking the insulation of the whole installation, proceed in the following manner:



WARNING! Insulation checks must be performed before connecting the DCA 500 / DCA 600 to the mains. Before proceeding with the insulation resistance measurements make sure that the DCA 500 / DCA 600 is disconnected from the mains.

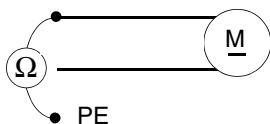

- 1.) Check that the motor cable is disconnected from the DCA 600 output terminals C1 and D1.
- 2.) Measure the insulation resistances of motor cable and the motor between each phase and Protective Earth, using a measuring voltage at least equal to the mains voltage, but not higher than 500 VDC. The insulation resistance must be higher than 1 MΩ.

Mains Fuses

Fuses are needed to protect the DC converter in case of an internal short circuit. The DCA 500 / DCA 600 Enclosed Converter is equipped with internal input fuses. For more information see manuals *System Description* and *Technical Data*. If a fuse is blown, it must be replaced with the proper ultrarapid fuse.

Cabling Instructions

Power Cables The mains and motor cables must be dimensioned *according to local regulations* and:

- 1.) to carry the DCA 500 / DCA 600 load current
- 2.) for at least 60 °C (140 °F)
- 3.) to fulfil short-circuit protection
- 4.) the inductance and impedance of the cable must be rated according permissible touch voltage appearing under fault conditions (so that the fault point voltage will not rise too high when an earth fault occurs).
- 5.) the cable screens according to safety regulations.

Control / Signal Cables The cables for digital signals, which are longer than 3 m and all cables for analogue signals, must be screened. Each screen must be connected at **both** ends by metal clamps (see *Figure 3-1*) or comparable means directly on clean metal surfaces, if **both earthing points belong to the same earth line**. Otherwise a capacitor (e.g. 3.3 nF/3000 V) must be connected to earth on one end. In the converter cabinet this kind of connection must be made directly on the sheet metal close to the terminals (see *Figure 3-3* ③) and if the cable comes from outside also on the PE bar (see *Figure 3.3* ① and ②). At the other end of the cable the screen must be well connected with the housing of the signal emitter or receiver.

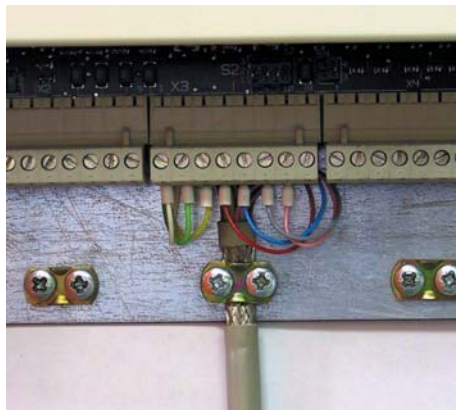

Figure 3-1 Connection of a cable screen with the aid of metal clamp to the metal surface

A double shielded twisted pair cable (*Figure 3-2 a*), e.g. JAMAK by NK Cables, Finland) must be used for analogue signals and the pulse encoder signals. Employ one individually shielded pair for each signal. Do not use common return for different analogue signals.

A double shielded cable is the best alternative for low voltage digital signals but single shielded twisted multipair cable (*Figure 3-2 b*) is also

usable.

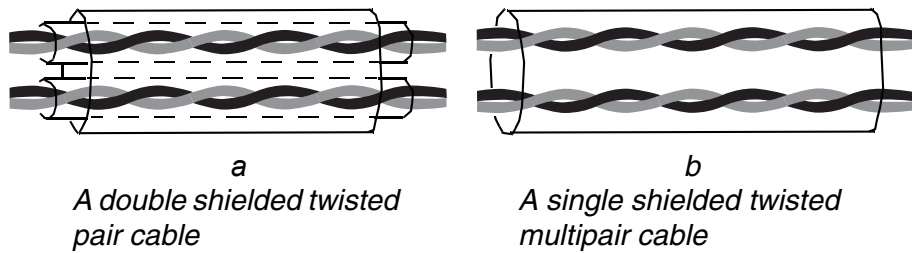

Figure 3-2 Different shielded twisted cables

Pairs should be twisted as close to terminals as possible.

The analogue and digital signals should be run in separate, screened cables.

Relay-controlled signals, providing their voltage does not exceed 48 V, can be run in the same cables as digital input signals. It is recommended that the relay-controlled signals be run as twisted pairs.



Caution: Never mix 24 VDC and 115 / 230 VAC signals in the same cable!

Co-axial Cables

Recommendations for use with DC Enclosed Converters series DCA 500 / DCA 600:

- 75 Ω type;
- RG59 cable with diameter 7 mm or RG11 cable 11 mm;
- The maximum cable length is 300 m.

Relay Cable

Cable types with braided metallic screens (e.g. ÖLFLEX, LAPPKABEL, Germany) has been tested and approved by ABB.

Control Panel Cable

In remote use the cable connecting the Control Panel CDP 312 to the DCS 500 / DCS 600 thyristor power converter module must not exceed 3 meters. The cable type tested and approved by ABB is included in the Control Panel option kits.

Optical Cables

The max. cable length for optical cables depends on the converter family (series DCA 500, DCA 600 ...) and on the type of optical cable selected (plastic or glass fibre, HCS silicate); for details please refer to the corresponding manual *Technical Data*. Moreover follow the instructions concerning the use of optical cables given by the cable suppliers.

Connection example in accordance with EMC

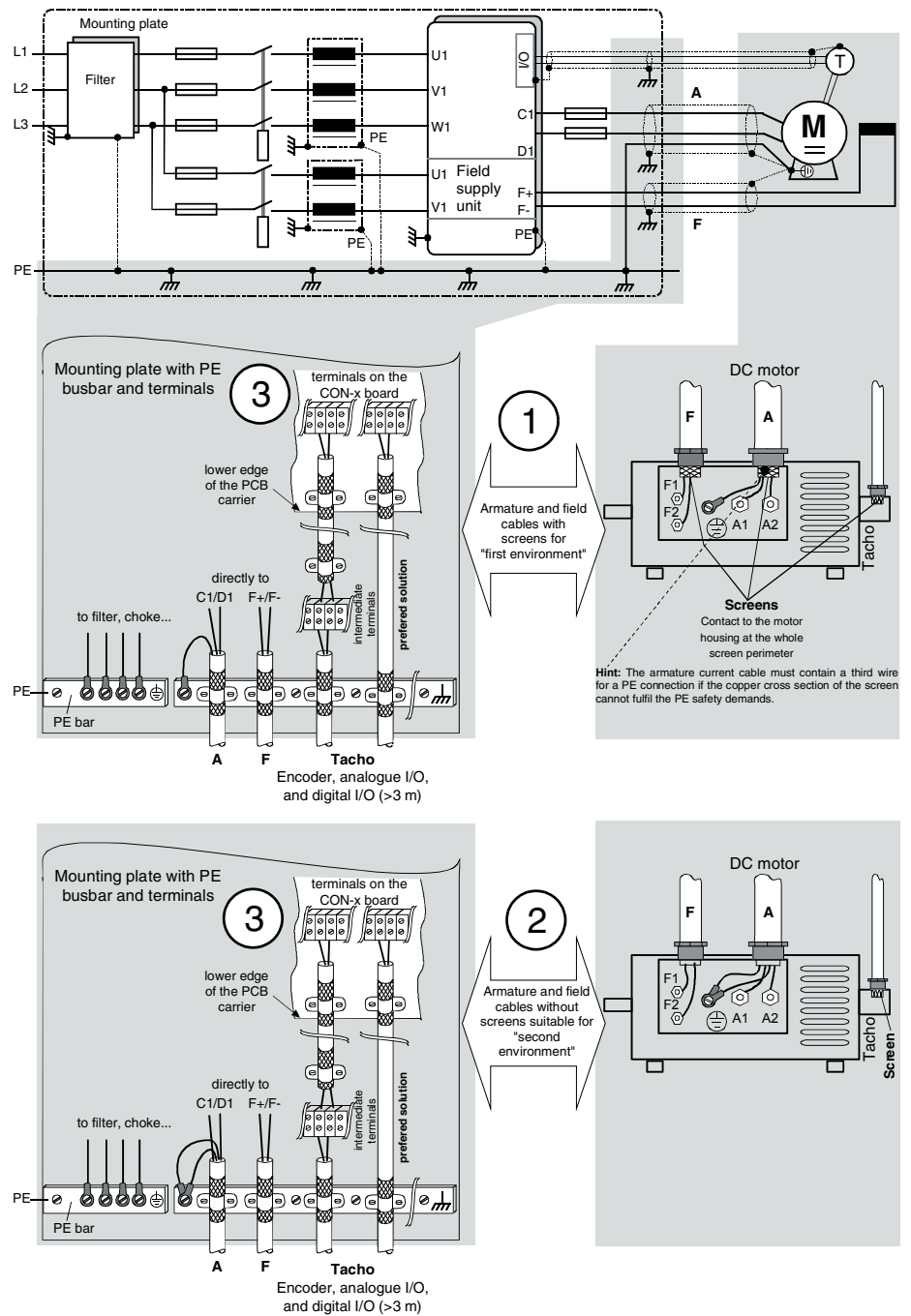

Figure 3-3 Connection example in accordance with EMC

Important hint: The example shows the principle structure of a DC drive and its connections. It is not a binding recommendation, and it cannot respect all conditions of a plant. Therefore each drive must be considered separately and with respect to the special application. Additionally the general installation and safety rules must be taken into account.

Cross-sectional areas - Tightening torques Recommended cross-sectional area to **DINVDE 0276-1000** and **DINVDE 0100-540 (PE)** trefoil arrangement.

Recommended cross-sectional areas for AC-connection.

Unit type	AC - connection (U, V, W) + PE					Size
	IAC [A~]	Amount of single cores and cross-sectional area connected per phase / PE (1) [mm²]	Amount of holes per phase for single drives ; Group drives are connected via incoming supply units; For size C1 terminals are used	Size of screws (2); Not for UL	UL as per Nema 2 (3):	
					Amount of holes per phase for single drives; Group drives are connected via incoming supply units; For size C1 terminals are used	
400 V / 500 V						
DCA 60x-0025-45/55-D	18	1 * 6²	1 terminal (16-95mm²)		1 terminal (16-95mm²)	C1
DCA 60x-0050-45/55-D	37	1 * 10²	1 terminal (16-95mm²)		1 terminal (16-95mm²)	
DCA 60x-0075-45/55-D	55	1 * 16²	1 terminal (16-95mm²)		1 terminal (16-95mm²)	
DCA 601-0140-45/55-D	94	1 * 35²	1 terminal (16-95mm²)		1 terminal (16-95mm²)	
DCA 602-0140-45/55-D	103	1 * 35²	1 terminal (16-95mm²)		1 terminal (16-95mm²)	
DCA 601-0250-45/55-D	172	1 * 95²	1	M12	2	C2
DCA 602-0250-45/55-D	185	1 * 95²	1	M12	2	
DCA 601-0350-45/55-D	234	1 * 120²	1	M12	2	
DCA 602-0350-45/55-D	246	1 * 120²	1	M12	2	
DCA 601-0520-45/55-D	328	1 * 185²	1	M12	2	
DCA 602-0520-45/55-D	369	1 * 185²	1	M12	2	C2b
DCA 601-0680-45/55-D	443	2 * 150²	2	M12	4	
DCA 602-0680-45/55-D	492	2 * 150²	2	M12	4	
DCA 601-0820-45/55-D	558	2 * 185²	2	M12	4	
DCA 602-0820-45/55-D	615	2 * 185²	2	M12	4	
DCA 601-1000-45/55-D	664	2 * 240²	2	M12	4	A5
DCA 602-1000-45/55-D	738	2 * 240²	2	M12	4	
DCA 60x-1203-45/55-D	935	4 * 150²	2	M12	on request	
DCA 60x-1203T-45/55-D	935	4 * 150²	2	M12		
DCA 60x-1503-45/55-D	1169	4 * 185²	3	M12		
DCA 60x-2003-45/55-D	1517	6 * 150²	3	M12		
DCA 60x-2500-45/55-D	2050	8 * 185²	8	M12		
DCA 60x-3300-45/55-D	2706	10 * 185²	8	M12		
DCA 60x-4000-45/55-D	3280	10 * 240²	11 (with ACB) 9 (without ACB)	M12		
DCA 60x-5150-45/55-D	4223	14 * 240²	14	M12		
DCA 60x-3300-45/55PD	5084	2 x 10 * 185²	request on			
DCA 60x-4000-45/55PD	6232	2 x 10 * 240²				
DCA 60x-5150-45/55PD	7995	2 x 14 * 240²				
600 V / 690 V						
DCA 60x-0050-65-D	37	1 * 10²	1 terminal (16-95mm²)		1 terminal (16-95mm²)	C1
DCA 601-0110-65-D	78	1 * 25²	1 terminal (16-95mm²)		1 terminal (16-95mm²)	
DCA 602-0110-65-D	82	1 * 25²	1 terminal (16-95mm²)		1 terminal (16-95mm²)	
DCA 601-0270-65-D	180	1 * 95²	1	M12	2	C2
DCA 602-0270-65-D	187	1 * 95²	1	M12	2	
DCA 601-0450-65-D	303	1 * 185²	1	M12	2	
DCA 602-0450-65-D	328	1 * 185²	1	M12	2	
DCA 60x-0903-65/75-D	701	4 * 95²	2	M12	on request	
DCA 60x-1503-65/75-D	1169	4 * 185²	3	M12		
DCA 601-2003-65/75-D	1517	6 * 150²	3	M12		
DCA 60x-2050-65/75-D	1681	6 * 185²	8	M12		
DCA 60x-2500-65/75-D	2050	8 * 185²	8	M12		
DCA 60x-3300-65/75-D	2706	10 * 185²	8	M12		
DCA 60x-4000-65/75-D	3280	10 * 240²	11 (with ACB) 9 (without ACB)	M12		
DCA 60x-4750-65/75-D	3895	12 * 240²	14	M12		
DCA 60x-3300-65/75PD	5084	2 x 10 * 185²	request on			
DCA 60x-4000-65/75PD	6232	2 x 10 * 240²				
DCA 60x-4750-65/75PD	7380	2 x 12 * 240²				

Unit type	AC - connection (U, V, W) + PE				Size	
		Amount of single cores and cross-sectional area connected per phase / PE (1)	Amount of holes per phase for single drives ; Group drives are connected via incoming supply units; For size C1 terminals are used	Size of screws (2); Not for UL		UL as per Nema 2 (3): Amount of holes per phase for single drives; Group drives are connected via incoming supply units; For size C1 terminals are used
	IAC [A~]	[mm ²]				
790 V						
DCA 60x-2050-85-D	1681	6 * 185 ²	9	M12	on request	
DCA 60x-3200-85-D	2624	10 * 185 ²	9	M12		
DCA 60x-4000-85-D	3280	10 * 240 ²	9	M12		
DCA 60x-4750-85-D	3895	12 * 240 ²	14	M12		
DCA 60x-3200-85PD	4986	2 x 10 * 185 ²	request on			
DCA 60x-4000-85PD	6232	2 x 10 * 240 ²				
DCA 60x-4750-85PD	7380	2 x 12 * 240 ²				
1000 V						
DCA 60x-2050-95-D	1681	6 * 185 ²	9	M12	on request	
DCA 60x-2650-95-D	2173	8 * 185 ²	9	M12		
DCA 60x-3200-95-D	2624	10 * 185 ²	9	M12		
DCA 60x-4000-95-D	3280	10 * 240 ²	9	M12		
DCA 60x-2650-95PD	4129	2 x 8 * 185 ²	request on			
DCA 60x-3200-95PD	4986	2 x 10 * 185 ²				
DCA 60x-4000-95PD	6232	2 x 10 * 240 ²				
1190 V						
DCA 60x-2650-15-D	2173	8 * 185 ²	request on		C4	
DCA 60x-3200-15-D	2624	10 * 185 ²				
DCA 60x-4000-15-D	3198	10 * 240 ²				
Incoming Supply Sections						
DCA630/5-1000-xx-D	1000	3 * 120 ²	8	M12	on request	
DCA630/5-2000-xx-D	2000	7 * 185 ²	8	M12		
DCA630/5-3000-xx-D	3000	9 * 240 ²	8	M12		
DCA630-4000-xx-D	4000	12 * 240 ²	8	M12		
DCA631-1000-xx-D	1000	3 * 120 ²	4	M12		
DCA631-2000-xx-D	2000	7 * 185 ²	4	M12		
DCA631-3000-xx-D	3000	9 * 240 ²	4	M12		
DCA631-4000-xx-D	4000	12 * 240 ²	on request			
DCA632-1000-xx-D	1000	3 * 120 ²	4	M12		
DCA632-2000-xx-D	2000	7 * 185 ²	8	M12		
DCA632-3000-xx-D	3000	9 * 240 ²	8	M12		
DCA632-4000-xx-D	4000	12 * 240 ²	on request			
				8		
				on request		
(1) Recommendation by ABB: - Use cable type VPE (90°C; 194°F) with 4 cores - AC - connection: U, V, W and PE - DC - connection: L+, L- and 2 * PE - Ambient temperature: 40°C; 104°F - Load: 100%			(2) Tightening torque: M10 = 25 Nm; 18.5 ft. - lbs. M12 = 50 Nm; 37 ft. - lbs.			(3) Diameter of all holes: 14 mm

Figure 3-4 Recommended cross-sectional areas - tightening torques AC-connection

Recommended cross-sectional areas for DC-connection

Unit type	DC - connection (U+, U-) + 2 * PE						Size	
	DC I [A]	Amount of single cores and cross-sectional area connected per phase / PE (1) [mm ²]	With DC - fuses		Without DC - fuses			
			Amount of holes for connection per phase	Size of screws (2)	Amount of holes for connection per phase; For size C1 terminals are used	Size of screws (2); Not for UL		UL as per Nema 2 (3); Amount of holes per phase for single drives; For size C1 terminals are used
400 V / 500 V								
DCA 60x-0025-45/55-D	22	1 * 6 ²	2	M10	1 terminal (16-95mm ²)		1 terminal (16-95mm ²)	C1
DCA 60x-0050-45/55-D	45	1 * 10 ²	2	M10	1 terminal (16-95mm ²)		1 terminal (16-95mm ²)	
DCA 60x-0075-45/55-D	67	1 * 16 ²	2	M10	1 terminal (16-95mm ²)		1 terminal (16-95mm ²)	
DCA 601-0140-45/55-D	115	1 * 35 ²	2	M10	1 terminal (16-95mm ²)		1 terminal (16-95mm ²)	
DCA 602-0140-45/55-D	125	1 * 35 ²	2	M10	1 terminal (16-95mm ²)		1 terminal (16-95mm ²)	
DCA 601-0250-45/55-D	210	1 * 95 ²	2	M10	1	M10	4	C2
DCA 602-0250-45/55-D	225	1 * 95 ²	2	M10	1	M10	4	
DCA 601-0350-45/55-D	285	1 * 120 ²	2	M10	1	M10	4	
DCA 602-0350-45/55-D	300	1 * 120 ²	2	M10	1	M10	4	
DCA 601-0520-45/55-D	400	1 * 185 ²	2	M10	1	M10	4	
DCA 602-0520-45/55-D	450	1 * 185 ²	2	M10	1	M10	4	C2b
DCA 601-0680-45/55-D	540	2 * 150 ²	2	M10	1	M12	4	
DCA 602-0680-45/55-D	600	2 * 150 ²	2	M10	1	M12	4	
DCA 601-0820-45/55-D	680	2 * 185 ²	2	M10	1	M12	4	
DCA 602-0820-45/55-D	750	2 * 185 ²	2	M10	1	M12	4	
DCA 601-1000-45/55-D	810	2 * 240 ²	2	M10	1	M12	4	A5
DCA 602-1000-45/55-D	900	2 * 240 ²	2	M10	1	M12	4	
DCA 60x-1203-45/55-D	1140	4 * 150 ²			8	M12	8	
DCA 60x-1203T-45/55-D	1140	4 * 150 ²			8	M12	8	
DCA 60x-1503-45/55-D	1425	5 * 185 ²			8	M12	8	
DCA 60x-2003-45/55-D	1850	6 * 185 ²			8	M12	8	C4
DCA 60x-2500-45/55-D	2500	8 * 185 ²			8	M12	8	
DCA 60x-3300-45/55-D	3300	11 * 185 ²			8	M12	8	
DCA 60x-4000-45/55-D	4000	12 * 240 ²			8 (with ACB) 9 (without ACB)	M12	8	
DCA 60x-5150-45/55-D	5150	15 * 240 ²			14	M12	8	
DCA 60x-3300-45/55PD	6200	2 x 11 * 185 ²					8	C4P
DCA 60x-4000-45/55PD	7600	2 x 12 * 240 ²					8	
DCA 60x-5150-45/55PD	9750	2 x 15 * 240 ²					8	
600 V / 690 V								
DCA 60x-0050-65-D	45	1 * 10 ²	2	M10	1 terminal (16-95mm ²)		1 terminal (16-95mm ²)	C1
DCA 601-0110-65-D	95	1 * 25 ²	2	M10	1 terminal (16-95mm ²)		1 terminal (16-95mm ²)	
DCA 602-0110-65-D	100	1 * 25 ²	2	M10	1 terminal (16-95mm ²)		1 terminal (16-95mm ²)	
DCA 601-0270-65-D	220	1 * 95 ²	2	M10	1	M10	4	C2
DCA 602-0270-65-D	240	1 * 95 ²	2	M10	1	M10	4	
DCA 601-0450-65-D	370	1 * 185 ²	2	M10	1	M10	4	
DCA 602-0450-65-D	400	1 * 185 ²	2	M10	1	M10	4	
DCA 60x-0903-65/75-D	855	4 * 95 ²			8	M12	8	
DCA 60x-1503-65/75-D	1425	5 * 185 ²			8	M12	8	
DCA 601-2003-65/75-D	1850	6 * 185 ²			8	M12	8	
DCA 60x-2050-65/75-D	2050	7 * 185 ²			8	M12	8	
DCA 60x-2500-65/75-D	2500	8 * 185 ²			8	M12	8	
DCA 60x-3300-65/75-D	3300	11 * 185 ²			8	M12	8	C4
DCA 60x-4000-65/75-D	4000	12 * 240 ²			8 (with ACB) 9 (without ACB)	M12	8	
DCA 60x-4750-65/75-D	4750	14 * 240 ²			14	M12	8	
DCA 60x-3300-65/75PD	6200	2 x 11 * 185 ²					8	
DCA 60x-4000-65/75PD	7600	2 x 12 * 240 ²					8	
DCA 60x-4750-65/75PD	9000	2 x 14 * 240 ²					8	C4P

Unit type	DC - connection (U+, U-) + 2 * PE							Size	
	DC I [A-]	Amount of single cores and cross-sectional area connected per phase / PE (1) [mm ²]	With DC - fuses		Without DC - fuses				
			Amount of holes for connection per phase	Size of screws (2)	Amount of holes for connection per phase; For size C1 terminals are used	Size of screws (2); Not for UL	UL as per Nema 2 (3); Amount of holes per phase for single drives; For size C1 terminals are used		
790 V									
DCA 60x-2050-85-D	2050	7 * 185 ²			9	M12	on request	C4	
DCA 60x-3200-85-D	3200	11 * 185 ²			9	M12			
DCA 60x-4000-85-D	4000	12 * 240 ²			9	M12			
DCA 60x-4750-85-D	4750	14 * 240 ²			14	M12			
DCA 60x-3200-85PD	6080	2 x 11 * 185 ²			request on			C4P	
DCA 60x-4000-85PD	7600	2 x 12 * 240 ²							
DCA 60x-4750-85PD	9000	2 x 14 * 240 ²							
1000 V									
DCA 60x-2050-95-D	2050	7 * 185 ²			9	M12	on request	C4	
DCA 60x-2650-95-D	2650	9 * 185 ²			9	M12			
DCA 60x-3200-95-D	3200	11 * 185 ²			9	M12			
DCA 60x-4000-95-D	4000	12 * 240 ²			9	M12			
DCA 60x-2650-95PD	5035	2 x 9 * 185 ²			request on			C4P	
DCA 60x-3200-95PD	6080	2 x 11 * 185 ²							
DCA 60x-4000-95PD	7600	2 x 12 * 240 ²							
1190 V									
DCA 60x-2650-15-D	2650	9 * 185 ²			request on		request on	C4	
DCA 60x-3200-15-D	3200	11 * 185 ²							
DCA 60x-4000-15-D	3900	12 * 240 ²							
(1) Recommendation by ABB: - Use cable type VPE (90°C; 194°F) with 4 cores - AC - connection: U, V, W and PE - DC - connection: L+, L- and 2 * PE - Ambient temperature: 40°C; 104°F - Load: 100%			(2) Tightening torque: M10 = 25 Nm; 18.5 ft. - lbs. M12 = 50 Nm; 37 ft. - lbs.			(3) Diameter of all holes: 14 mm			

Figure 3-5 Recommended cross-sectional areas - tightening torques DC-connection

You will find instructions on how to calculate the PE conductor’s cross-sectional area in VDE 0100 or in equivalent national standards. We remind you that power converters may have a current-limiting effect.

Cable Connections



WARNING! Make sure that the DC Enclosed Converter series DCA 500 / DCA 600 is disconnected from the mains network during installation and that the capacitors of the line filters are discharged.

Mains Cable Connection

This section describes the mains connections of the DCA 500 / DCA 600 enclosed converters.

The N conductor is not usually used although it is visible in the following diagrams.

Low Power Supply

A low current (< 300 A) cable connection when one cable is sufficient is shown in *Figure 3-6*.

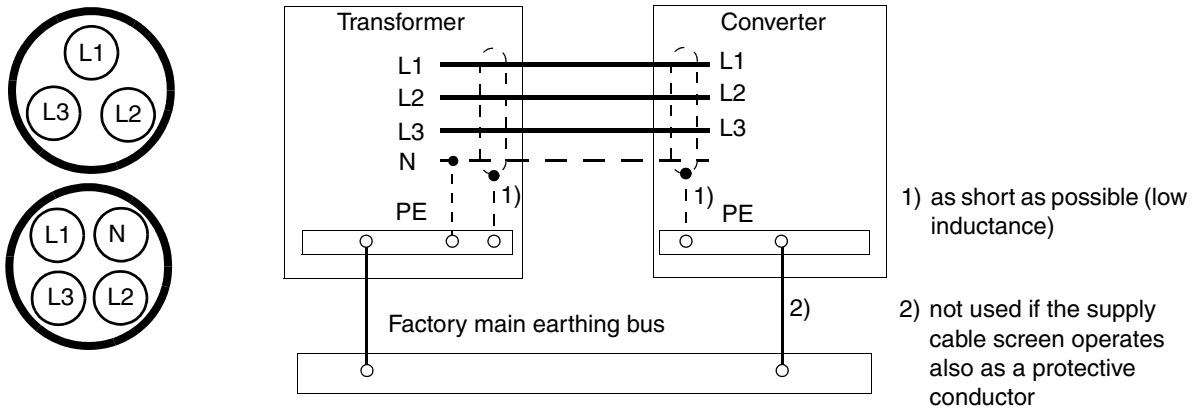

Figure 3-6 Low-current (<300 A) connection

High Power Supply

Busbar connection A high current (> 300 A) busbar connection is shown in Figure 3-7.

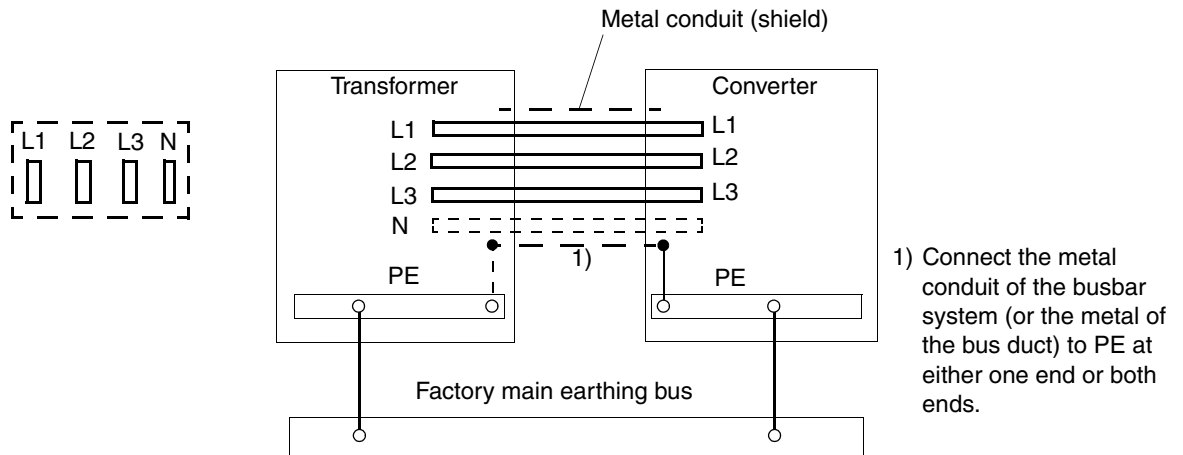

Figure 3-7 High-current (>300 A) busbar connection

Note: The paint should be removed to allow a good connection to the cabinet frames throughout the whole perimeter of the metal conduit (or a bus duct). The metal conduit (or the bus duct metal) should be electrically continuous throughout its complete length.

Cable Bus System The connection of a high current (> 300 A) cable bus system that consists of several cables is shown in Figure 3-8.

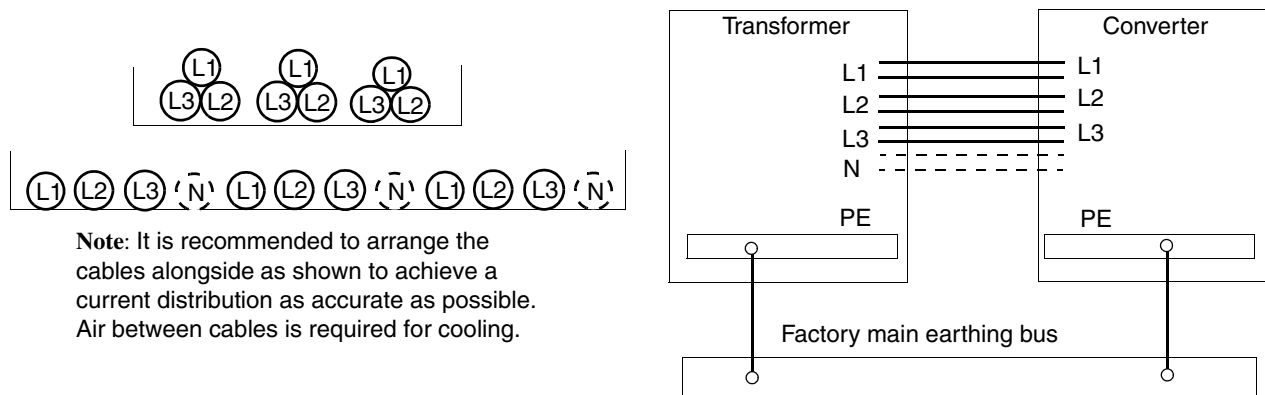

Figure 3-8 High-current (>300 A) cable bus connection

Note: Current derating of the cables is required when installing the cables in a cable tray. This derating factor must be taken into account as per the local electrical safety codes.

Single-core Cables with Concentric Protective Shields

When single-core cables equipped with concentric protective shields (metal) are used, the phase current will induce voltage to the cable shield. If the shields are connected to each other at both ends of the cable, current will flow in the cable shield. In order to prevent this and to ensure personal safety, the cable shield must be connected only to PE at the transformer side and insulated on the converter side. The connection is shown in *Figure 3-9*.

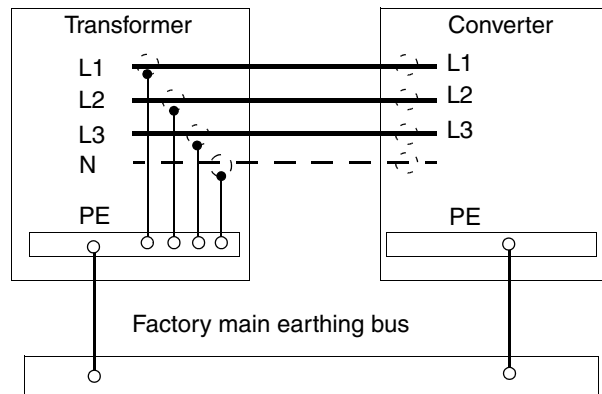
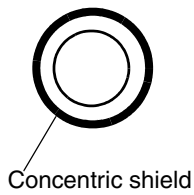

Figure 3-9 High-current (>300 A) single-core cable connection

Motor Cable Connection

Motor cable connection should be performed as indicated in the manual *Technical Guide* (3ADW000163).

Cable Tray or Bus Duct

Current derating of the cables is required when installing the cables in a cable tray or bus duct. This derating factor must be taken into account as per the local electrical safety codes.

For some market areas and large power applications, a bus duct may be used to supply the DC thyristor power converter modules. The metal of the bus duct should be grounded at both ends of the complete system. The paint should be removed to allow a good connection to the cabinet frames throughout the whole perimeter of the bus duct. The bus duct should be electrically continuous throughout its complete length.

Mechanical Cable Connections

The following sections provide some basic instructions for the routing and mechanical connection of cables. The mechanical cable connections are basically the same whether they are for an incoming cabinet or a DC thyristor power converter module (what changes between the various types are the cabinet dimension and the location of the terminals for the cables). The cabling direction may also vary (from top or bottom).

If necessary, the same screw can be used to connect two cable lugs at the busbar (sometimes not allowed because of local regulations, e.g. in USA). Always use a torque wrench for tightening the busbar connections.

Location of Cable Connections within the Cabinet

DC thyristor power converter modules series DCS 500 / DCS 600 are used in **DC Enclosed Converters** series **DCA 500 / DCA 600**. The standard version is equipped with a bottom entry for power and control cables. Basically all control cable connections are located on the left side of the cabinet.

Motor Cable Connection

Conductive Sleeves

Conductive sleeves are supplied by ABB as option to provide 360° high frequency grounding for motor cables. Follow these instructions:

- 1). Pull cable into the cabinet through the conductive sleeve.
- 2). If a rubber grommet is used, slide it over the cable.
- 3). Connect phase conductors to terminals.
- 4). Twist the shield wires of the cable together and connect them to ground terminal or PE busbar.
- 5). Peel off 3 to 5 cm of the outer cover of the cable above the entry plate for the 360° high frequency grounding.
- 6). Fasten the conductive sleeve to the cable shield with a cable tie.
- 7). Tie up the unused conductive sleeves with cable ties.

Cable Entry

Figure 3-10 shows a bottom cable entry for power cables of DCA 500 / DCA 600. Tighten the EMC sleeve on the stripped part of the cable with cable ties. For IP 54 units, add a rubber grommet on the cable under the EMC-cable-entry-plate.

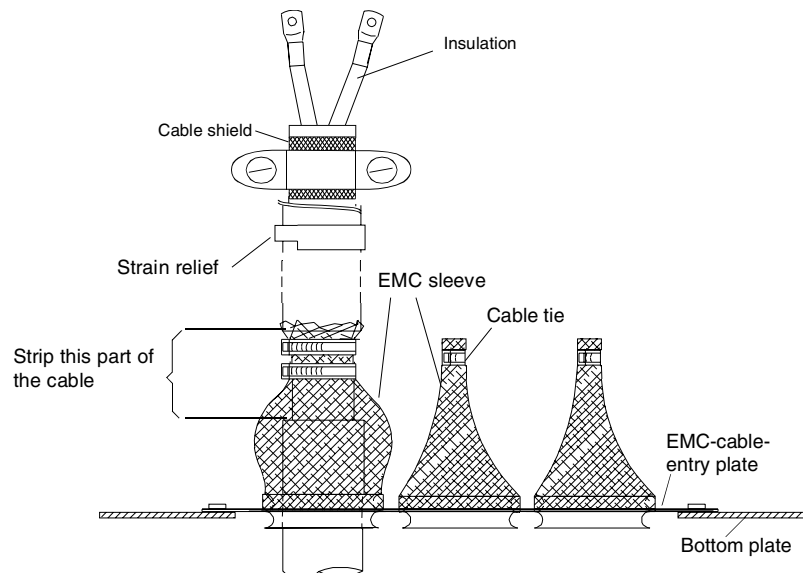

Figure 3-10 Conductive sleeves

Control Cable Connection

Connect the control cables to the appropriate terminal block (or optional terminal block and other options on the DIN rail at the left side of the cabinet). Tighten the screw to secure the connection. Connect the twisted screen (as short as possible) to the earthing rail \oplus of the terminal. See also *Figure 3-1* and *3-3*.

EMC Grounding at the Cable Entry

360° high frequency grounding of the control cable screen at the cable entry is available as an option from ABB (see *Figure 3-11*).

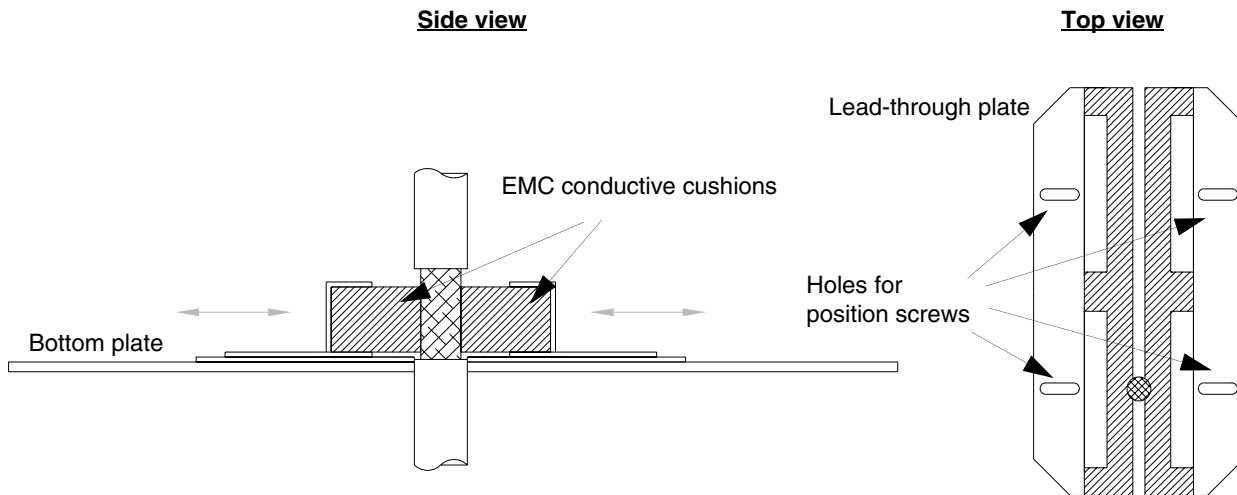

Figure 3-11 Conductive cushions

Special for Top Entry

When each cable has its own rubber grommet, sufficient IP and EMC protection can be achieved. However, if lots of control cables are connected to one cabinet, plan the installation beforehand as follows:

- 1). Make a list of the cables to be connected to the cabinet.
- 2). Sort the cables connected to the left into one group and the cables connected to the right into another group to avoid unnecessary crossing of cables inside the cabinet.
- 3). Sort the cables in each group according to size.
- 4). Group the cables for each grommet as follows:

Cable diameter in mm	Max. number of cables per grommet
≤ 13	4
≤ 17	3
< 25	2
≥ 25	1

- 5). Divide the bunches so that cables will be arranged according to size between the EMC conductive cushions.

View from below

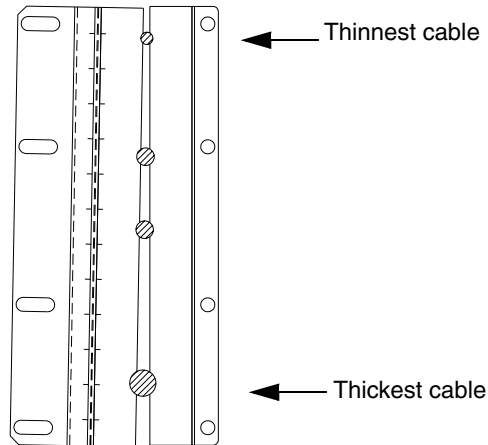

Figure 3-12 Lead-through plate

Bottom and Top Entry Proceed as follows:

- 1). Loosen the lead-through plate position screws. Pull the two parts apart.
- 2). Bottom entry
Lead the cable inside the cabinet through the EMC conductive cushions.
- Top entry
Lead the cable inside the cabinet through the grommet and the EMC conductive cushions. If you have several cables, bunch them together at the grommet, but ensure that each cable has a proper contact to the cushions on both sides.
- 3). Strip off the cable plastic sheath above the base plate (just enough to ensure proper connection of the bare screen and the EMC conductive cushions).

- 4). Earth the screen by means of the EMC conductive cushions:
 - a. If the outer surface of the screen is conductive:
 - Push the two parts of the lead-through plate together so that the EMC conductive cushions presses tightly around the bare screen.
 - b. If the outer surface of the screen is covered with non-conductive material:

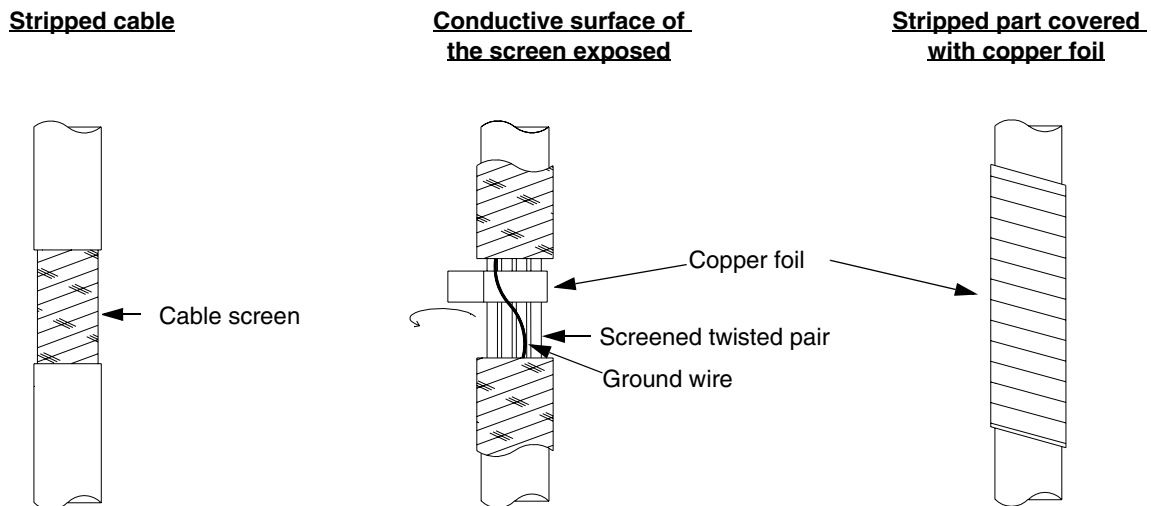

Figure 3-13 Cable screen

- Cut the screen at the midpoint of the bare part. Be careful not to cut the conductors.
 - Turn the screen inside out to expose its conductive surface.
 - Cover the turned screen and the stripped cable with copper foil to keep the shielding continuous. **Note:** The ground wire (if present) must not be cut.
 - Push the two parts of the lead-through plate together so that the EMC conductive cushions press tightly round the foil-covered screen.
- 5). Lock the two parts of the lead-through plate by tightening the positioning screws.

- 6). Top entry: If more than one cable go through a single grommet, the grommet must be sealed by Loctite 5221 (catalogue number 25551).

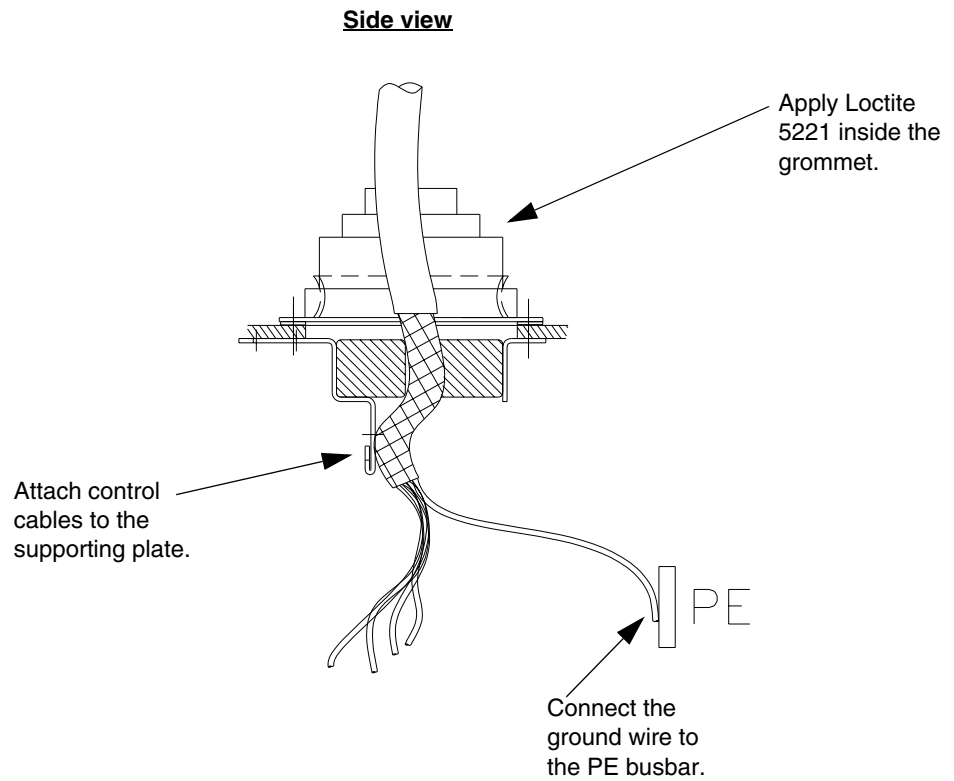

Figure 3-14 Top entry

**Installation of
Optional Modules
(only for DCA 600)**

This section gives general installation instructions for DCA 600 optional modules.

There are various serial interface options available for operation, commissioning, diagnosis and controlling. For the control and display panel CDP 312 are serial connections X33:/X34: on the SDCS-CON-2 available. Three additional serial interfaces are available on the SDCS-AMC-DC 2 board.

These interfaces use plastic or HCS optical fibres. Channel 3 is used for drive/PC interfacing. Channel 0 for fieldbus module interfacing or communication to the overriding control system. Channel 2 is used for Master-Follower link or for I/O extension. All three serial interfaces are independent from each other.

Different SDCS-AMC 2 boards are available to adapt optical cables, cable length and serial interfaces. The different SDCS-AMC 2 boards are equipped with 10 or 5 Mbaud optical transmitter and receiver devices.

A few basic rules must be considered:

- Never connect 5 Mbaud and 10 Mbaud devices.
- 5 Mbaud can handle only plastic fibre optic.
- 10 Mbaud can handle plastic or HCS cable.
- The branching unit NDBU 95 extends the maximum distance.
- The maximum distance and suitable configuration can be found in the manual *Configuration Instructions NDBU 85/95; Doc no.: 3ADW000100*.

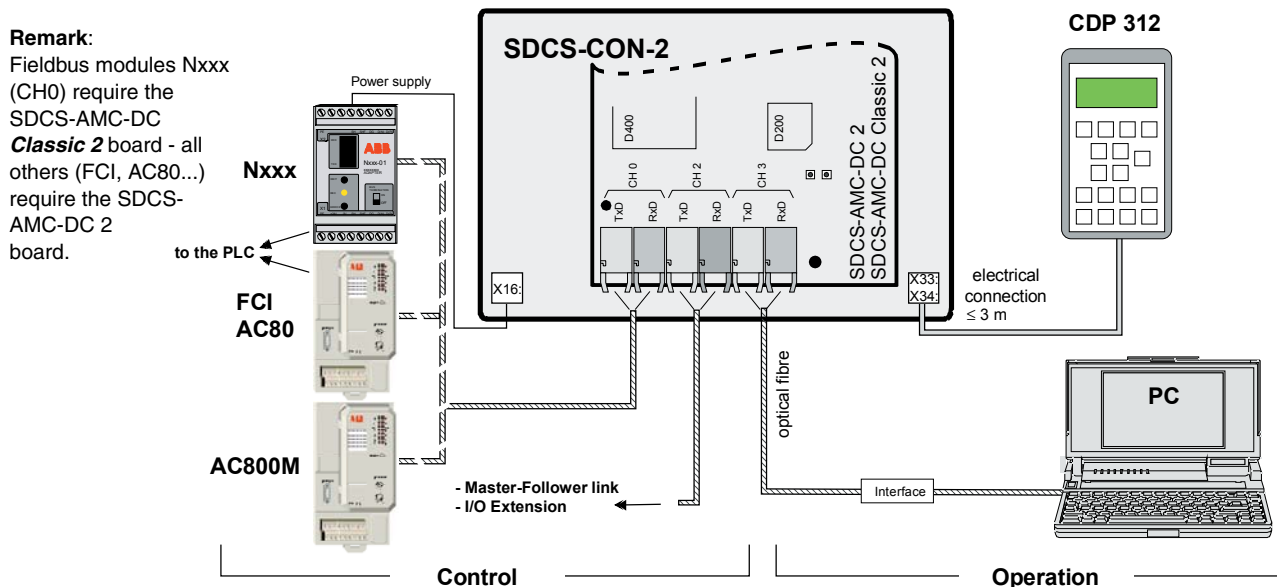

Figure 3-15 Options for serial communication

Fieldbus adapter modules

Nxxx bus adapter modules are supplied by a 24V output of the converter (e.g. X16 on SDCS-CON-2). The communication is established via a fiber optic cable from channel 0 (SDCS-AMC-DC Classic 2) to the Nxxx bus adapter.

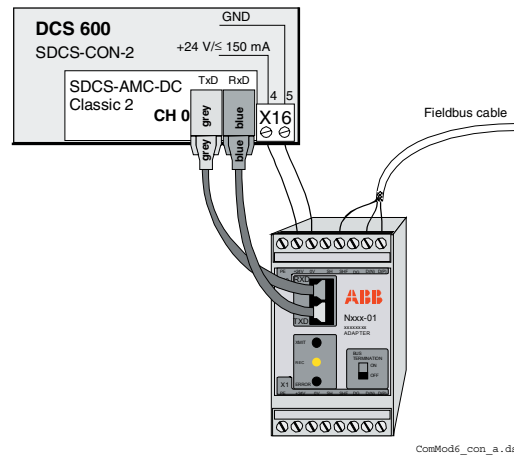

Figure 3-16 Connection of fieldbus adapter module

Fiber optic configurations

The following figures show several fiber optic configurations. For more configuration possibilities see publication 3AFE63988235 and manual Configuration Instructions NDBU 85/95 (3ADW000100).

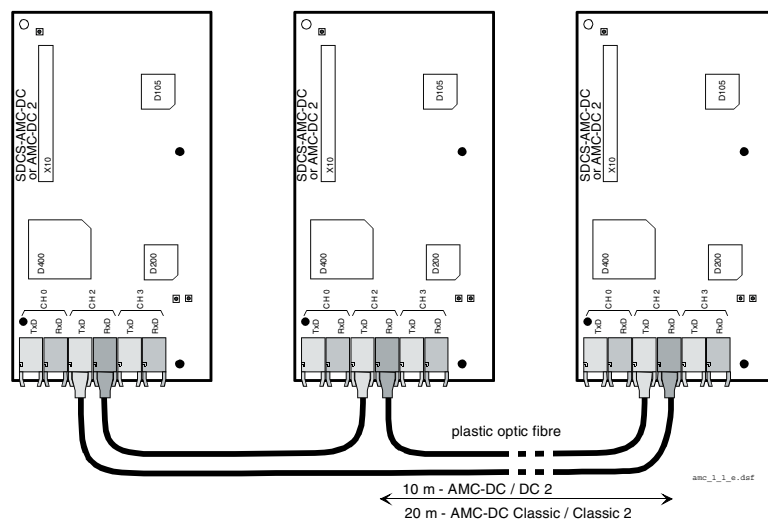

Figure 3-17 Connections at Master-Follower mode

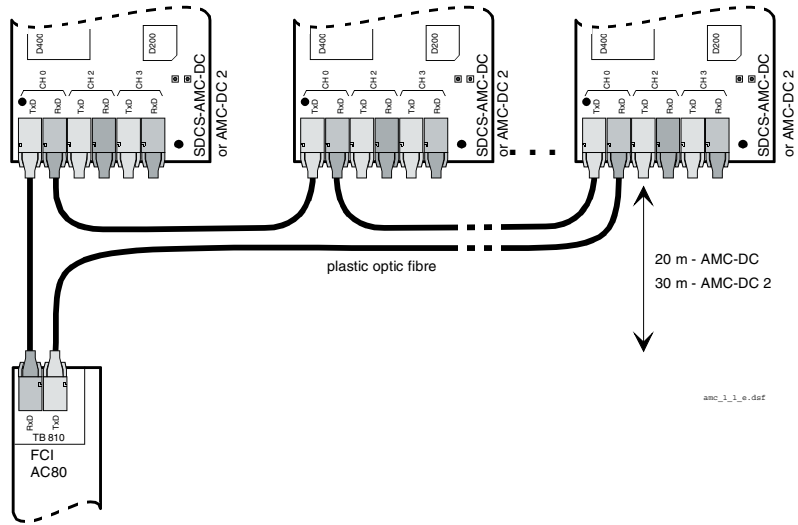

Figure 3-18 Module Bus connections to Advant controllers (ring)

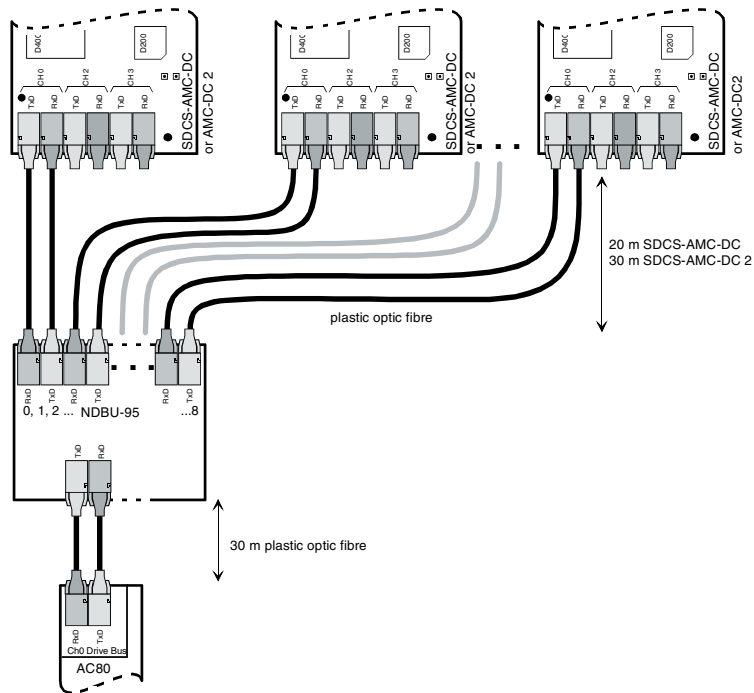

Figure 3-19 Drive Bus connections to Advant Controller 80 (star)

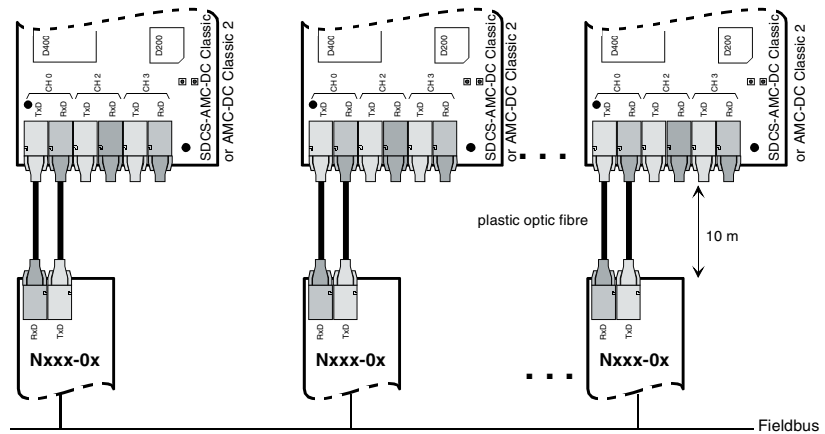

Figure 3-20 Connections to higher-level system (Communication modules)

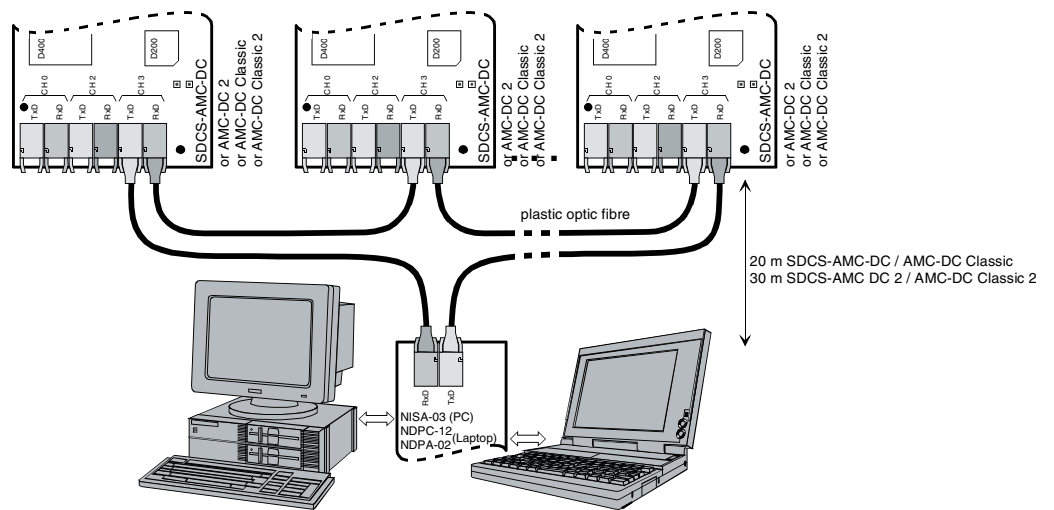

Figure 3-21 Connections to PC by ring (with control program DriveWindow)

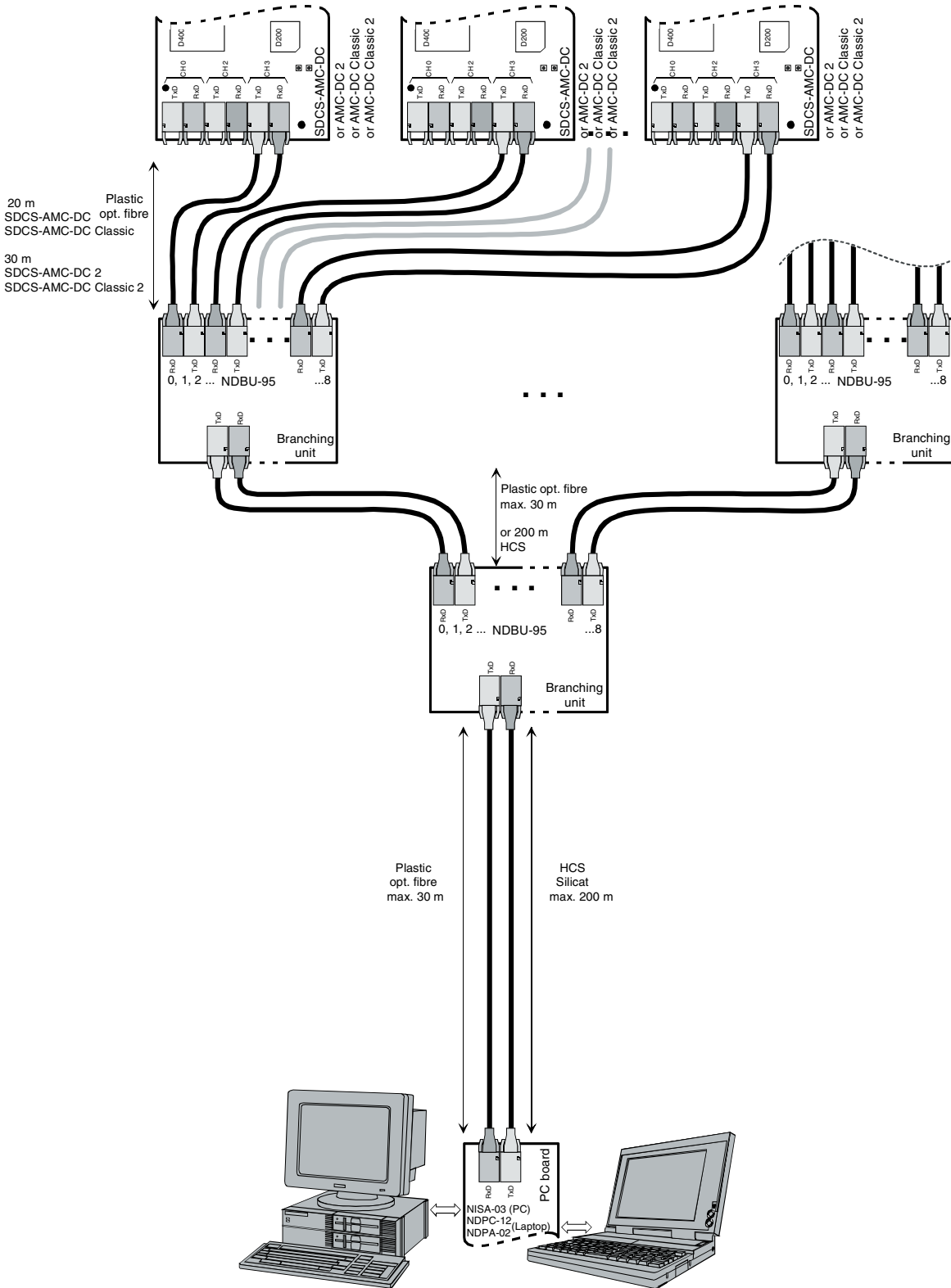

Figure 3-22 Connections to PC by star (with control program DriveWindow)

Chapter 4 – Installation Checklist

Installation Checklist

The mechanical and electrical installation of the DCA 500 / DCA 600 should be checked before start-up. It is advisable to go through the checklist below together with another person. Study carefully the Safety Instructions on the first pages of this manual before attempting any work on, or with, the unit.

INSTALLATION CHECKLIST

MECHANICAL INSTALLATION (see *Chapter 2 - Mechanical Installation*)

- The ambient operating conditions are acceptable (e.g. environmental conditions in the corresponding *System description*, fan data in the manual *Technical Data* and free space requirements in *Chapter 2 - Mechanical Installation*).
- The unit is mounted properly.
- Cooling air will flow freely:
 - the lifting bars (if used) are removed
 - the cabinet roof is attached properly
 - the filters (if used) are mounted properly
 - the C4 module (if used) air outlet is connected properly.

ELECTRICAL INSTALLATION (see *Chapter 3 – Electrical Installation*)

- Joining of the shipping splits:
 - the AC busbars and PE busbars are properly connected (see *Chapter 2 – Mechanical Installation*)
 - the internal control cables are properly connected.
- The converter unit and cabinets are earthed properly.
- The mains voltage matches the DC converter nominal input voltage.
- The setting of the internal 220/115 V transformer T2 corresponds to the supply voltage.
- The mains (input power) connections at U, V and W are OK.

INSTALLATION CHECKLIST

- The appropriate mains fuses are installed for units C1, C2, C2b (see *Technical Data*).
- Motor cable routing (armature and excitation) is OK.
- Check that the screens are properly installed at the motor and in the drive cabinet.
- The connections at L+, L-, F+ and F- are OK.
- The control connections are OK.
- If pulse encoder is used, check the encoder cables and correct direction of rotation (see *Technical Data*)
- PT 100, PTC, Klaxon cables: Check that the connections are appropriate for the type of sensor used in the motor.
- Check the prevention of unexpected start-up (on inhibit, coast stop) cables.
- Check the emergency stop cables.
- For all external cables make sure that both ends of the cables are connected and the cables do not cause any damage or danger when power is being switched on.
- Cleanliness of the cabinets and surroundings, e.g.:
 - there are no tools or other foreign objects inside the cabinets or waste left from installation e.g. cable trimmings
 - there is no garbage under the cabinets (the cooling air fan will draw the garbage inside the cabinets)
 - use a vacuum cleaner to remove any dirt. Do **not** use compressed air!).

Chapter 5 – Preventive Maintenance



WARNING! Before performing any maintenance the *Chapter Safety Instructions* at the beginning of this manual must be followed. Negligence of these instructions can cause injury or death.

Recommended regular maintenance

The DCS requires very little maintenance if installed in an appropriate environment. An annual check for dust accumulation and corrosion inside the module / cabinet is recommended.

Air Filters

When air filters are used, the filters should be checked regularly depending on environmental conditions. Clogged up filters prevent the proper cooling of the drive. Wash dirty filters with water (60°C) and detergent.

Cooling air pressure switch in converter modules type C4

The cooling air pressure switch must be checked regularly. The following actions have to take place:

- Make sure electrical safety is performed.
- Open the module's door and hold it in position to prevent any movement.
- Repeat it with the cabinet's door.
- Switch on the drive and try to turn the motor.
- The air pressure switch is ok when the converter is switched off by error "F50 NO C FAN"; crosscheck this result with the module's door closed.

Fan

The lifetime of the cooling fan is about 20.000 to 40.000 hours depending on the converter type. The actual lifetime depends on the usage of the DCS and the ambient temperature. Fan failure can be predicted by means of increasing noise from its bearings and a gradual rise of the heatsink temperature. If the DCS operates in a critical part of the process it is recommended to replace the fan once the above mentioned symptoms appear.

Heatsink

The DCS will run into overtemperature faults if the heatsinks are not clean. In an appropriate environment the heatsinks should be checked and cleaned annually. Use compressed air to remove the dust from the heatsinks (the air flow must be from bottom to top). Fan rotation caused by the compressed air must be stopped in order to prevent damage. Additionally use a vacuum cleaner to clean the dust from the air inlet and outlet.

Internal high current connections in converters type C4

The thyristors together with the heatsinks are stacked. Every single thyristor is connected to the DC+ and DC- busbars via flexible copper busbars. These busbars consist of 10 layers of preshaped sheet copper. This construction is able to compensate for small changes in length caused by temperature rise when current is flowing. The screw fixings between heatsink and flexible copper busbar have to withstand different types of mechanical stress. Therefore each fixing needs to be checked for correct torque. This check should be done regularly, e.g. annually or together with all the other work to be done for preventive maintenance.

Actions:

- Make sure all supply voltages are switched off, most important the supply for the power part (armature), for the electronic power part (SDCS-POW-1), for the converter fan and for other auxiliaries!
- Open the cabinet's and module's door; if needed secure them.
- Set a latching torque spanner to 25 Nm (18 lb-ft); a 17 mm nut is needed too.
- Check the torque of the screws marked within Figure 9-1 at the end of this chapter:
 - Apply the torque spanner to the screw and turn right until the right torque is indicated.
 - Don't loosen the screws by a left hand turn!
 - Put on a new marking, if appropriate.

Relays and electrical connections

Relays should be checked for proper function and all connections should be inspected and checked for tightness. Any signs of corrosion, especially at ground components, must be removed.

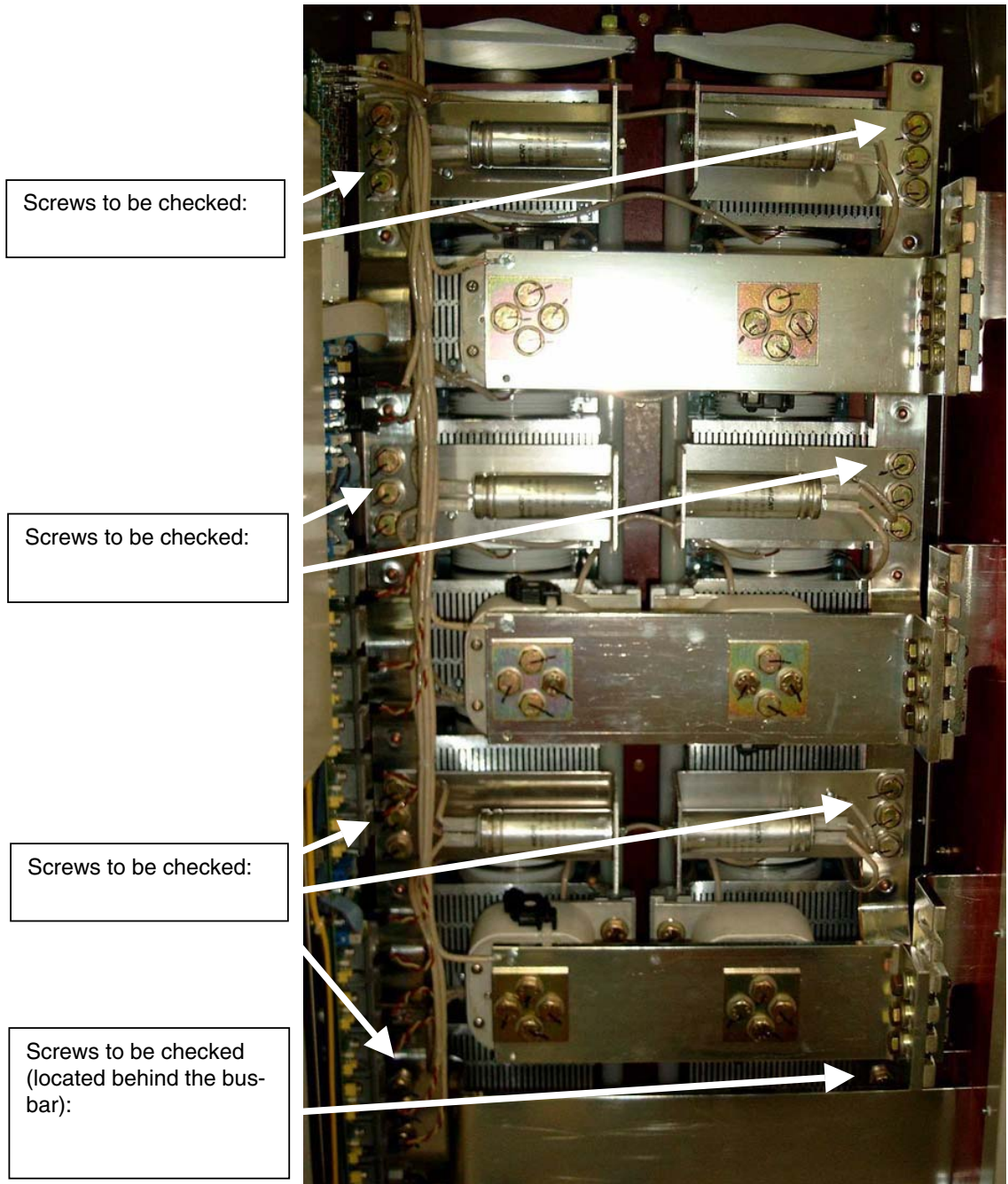

Figure 5-1 Power part of a converter module type C4



DC Drives Product Portfolio

DCS 400

The drive module for standard applications

- Integrated field supply (max. 20 A)
- Accurate speed and torque control
- Extremely small and compact design
- Very easy installation and commissioning
- Express delivery
- **Power range: 10...500 kW (13...670 HP)**



DCS 500B / DCS 600

The drive module for demanding applications

- Free programming of software
- 6- and 12-pulse configuration up to 10 MW/ 13,000 HP and more
- Plain text display
- **Power range: 10...5000 kW (13...6700 HP)**



DCE 400 plus

Highly integrated panel

- Extremely small and compact design
- Contains:
 - DCS 400 module
 - AC fuses
 - Auxiliary transformer
 - Motor fan starter with protection
 - Main contactor
- **Power range: 20...130 kW (26...174 HP)**



DCS 400 / DCS 500 Easy Drive

The complete standard cabinet solution

- Pre-engineered
- Easy installation and commissioning
- Protection class: IP 21
- Plain text display
- Short delivery time
- **Power range: 50...1350 kW (65...1800 HP)**



DCA 500 / DCA 600

For complex, completely engineered Drive System in common cabinet design

- Flexible and modular hardware structure
- 6- and 12-pulse configuration up to 18 MW/ 23,000 HP and more
- Pre-programmed applications:
 - Metals, Cranes, P&P application, Mining
- **Power range: 10...18000 kW (13...23000 HP)**





ABB Automation Products GmbH
Postfach 1180
68619 Lampertheim • GERMANY
Tel: +49 (0) 62 06-5 03-0
Fax: +49 (0) 62 06-5 03-6 09
www.abb.com/dc



091R0301A3110000

Ident. Nr.: 3ADW 000 091 R0301 REV C
03_2003