

# Current transformers for large AC generators



The last thing a utility wants is a GCT failure causing an unexpected service outage. This alone makes the strong case for a robust preventative maintenance program that includes a sound GCT inspection.

**Author**  
Randy Mullikin, Sr. Design  
Engineer, ABB Inc.

## Abstract

Large AC generators (1–1500 MW) are a critical piece of grid infrastructure to support ever-growing electricity demands. Specialty current transformers, called generator current transformers (GCTs), are commonly installed on the generator’s terminal bushing or isolated-phase bus and are critical for metering the very high current flows in the circuit and protecting the equipment. Not all GCTs are made equal. Specialized design methods and materials result in more accurate measurements and more reliable performance, leading to reduced maintenance, downtime and replacement costs. Special shield windings must be used to prevent the negative effects of stray magnetic flux fields from currents on adjacent phases, as well as field-proven materials and manufacturing methods designed to withstand the heat and vibration commonly present in generation applications.

## Introduction to CTs

Current transformers (CTs) are electromagnetic devices found throughout the power industry on nearly every piece of equipment used for the reliable delivery and control of electrical energy. CTs come in various shapes and sizes, depending on where and how they are used. In general, CTs measure high amounts of electric current and convert these high currents into lower, more manageable levels. The output of the CT is proportional to that measured by its effective turns ratio. This output can be used for the accurate measurement of energy, for protection of equipment from harmful and damaging magnitudes encountered during short circuits or electrical faults, or for monitoring current flow for the purpose of controlling other devices. Often, CTs are not directly visible because they may be installed inside enclosures, power transformers or power circuit breakers, but their presence, wherever found, is critical.

### How CTs work

CTs work on the magnetic principles based on Faraday's Law. With some help from Lenz's Law, Faraday developed the following fundamental equation:

$$E = -N \frac{d\Phi}{dt}$$

This relationship is the foundation of all transformers, inductors and rotating machines such as motors and generators. Through other relationships that we will not discuss here, along with several substitutions and calculus, the fundamental equation is rewritten into a more recognizable and useful expression:

$$e = -4.44 k f N \beta A \times 10^{-8} (V_{RMS})$$

where:

- $e$  = induced voltage (emf)
- $k$  = constant of proportionality
- $f$  = frequency, Hz
- $N$  = turns in winding being evaluated
- $\beta$  = flux density
- $A$  = net core area

For a sinusoidal wave form

### CT core construction

The transformer core is the component of the CT that provides strong magnetic coupling between the primary and secondary output circuit of the CT. The core is made of electrical-grade grain-oriented silicon-iron steel. Because of this, the core determines the boundaries of operation. Core steel has a well-defined characteristic in several grades defined by maximum allowable core loss. The characteristic limits are defined by its magnetization (B-H) curve, which is simply induction (b) versus exciting force (H).

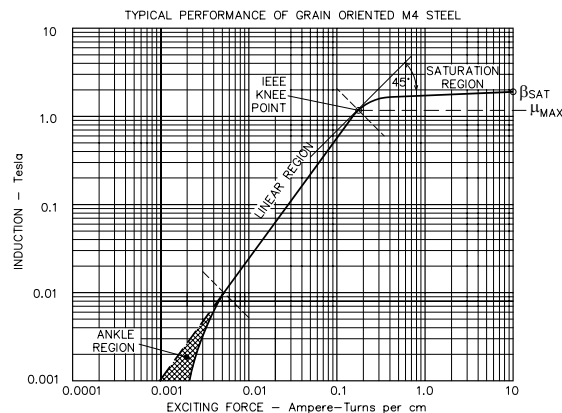

Looking at the core curve in figure 1, three regions are of particular interest. The ankle region, which is at very low inductions, has very unstable and unpredictable performance. This is due to another steel property known as initial permeability, which is its ability to support a magnetic field. The next region is what we refer to as the linear portion, where performance is stable and very predictable. This region is the normal working range for CTs and is between the ankle and knee point. The knee point is where the core steel begins to enter the next region, saturation.

The knee is referred to as the point of maximum permeability. Once the core enters saturation, more energy is consumed by the core, and the CT output becomes distorted and no longer sinusoidal. For metering duty, we must always operate in the linear region of the curve over the entire metered range. For protection duty, we should be around the knee or higher, under maximum fault conditions. But under normal operating conditions, we are low in the linear region.

Geometry of the core plays an important role in performance. The most simple and basic core geometry is that of a toroid, which is strip steel continuously wound on a round mandrel of a fixed diameter to its designed build-up (see figure 2). This manufacturing process introduces mechanical stresses in the core. To restore it to the expected characteristic requires a high temperature stress-relief anneal in a controlled furnace environment. The core is then insulated for the secondary winding, which encircles the core area, running along the entire core periphery with the turns equally and fully distributed (see figure 3). Once the winding is in place, the coil is then insulated and assembled for its designated service.

This is what is referred to as a bushing-type CT (BCT), also known as a window-type CT. In application, the primary winding is a single turn conductor passing through the center of the window. Most BCTs are rated for 600 V insulation, thereby requiring the main conductor, through which the current to be measured is flowing, to provide the primary insulation. There are other types of core construction, winding arrangements and insulation systems that are beyond the scope of this article — our discussion from this point onward will relate to the BCT type.

- 02 Toroidal cores on conveyor
- 03 Typical non-shielded secondary winding
- 04 BCTs mounted on HV bushing of a large AC generator



— 02

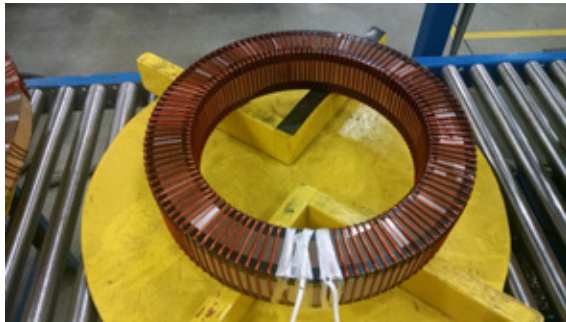

— 03

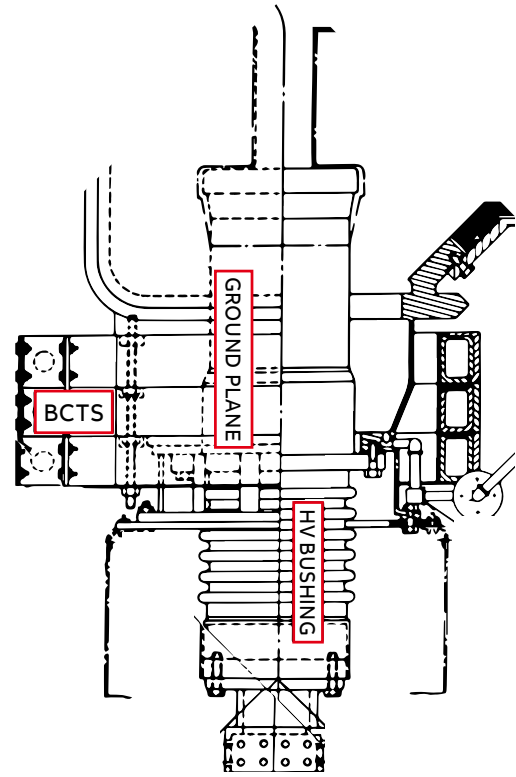

— 04

**CT positioning**

In practice, the BCT is positioned over a high voltage (HV) bushing (see figure 4). A portion of this bushing is designated for BCT placement with a ground sleeve that shields the BCT from the primary voltage, regardless of its value. As the primary current passes through the bushing, a magnetic field radiates around the bushing. This field goes through the air and penetrates the core. The core absorbs a portion of this flux based on the number of secondary turns and the core area to establish its working flux density. While envisioning this configuration, it should be apparent that the CT is connected in series with the primary line. It measures the current flow in amperes. The primary circuit offers a constant current source through a low impedance loop with very little regulation.

**CT operating principles**

Referring to the well-known transformation ratio, we can establish other operating principles that apply to CTs. We are familiar with the normal relationship of volts, turns and power:

$$V_p / V_s = N_p / N_s = I_p / I_s$$

And from the law of conservation of energy, we know that:

$$\text{power IN (VA)} = \text{power OUT (VA)}$$

$$V_p \times I_p = V_s \times I_s$$

And more specifically, we can relate CTs in terms of ampere-turn balance:

$$I_p N_p = I_s N_s$$

We know that transformers are not perfect, and that transformation comes at a cost, which is core loss or energy consumed by the core during the induction process. The actual ampere-turns balance is:

$$\text{Primary ampere-turns} - \text{Magnetizing ampere-turns} = \text{Secondary ampere-turns}$$

$$I_p N_p - I_{ex} N_p = I_s N_s$$

where:

- $V_p$  = primary voltage       $V_s$  = secondary voltage
- $I_p$  = primary current       $I_s$  = secondary current
- $N_p$  = primary turns       $N_s$  = secondary turns
- $I_{ex}$  = core exciting current

- 05 Flux linking into a core center
- 06 Flux linking parallel and perpendicular to the core
- 07 Core off with non-linear flux linking

**CT saturation**

During normal CT operation, energy is depleted from the primary source, thus acting like a shunt. This depletion of energy results in errors on the secondary side. As the secondary impedance increases, the voltage across the secondary terminals increases. It is this voltage that establishes the working flux in the CT core. The CT is not voltage-dependent but is voltage-limited. This limitation is, as previously mentioned, saturation. When the burden on the CT is high enough — or when under fault conditions, a high enough voltage develops across the CT winding — it will force the CT into saturation. The output of the CT winding then becomes extremely non-sinusoidal, regardless of what is happening in the primary circuit, and no longer provides valid replication. At this point, nearly all the available energy is consumed by the core, leaving none left to support the secondary circuit. Fault conditions are momentary; otherwise, the core can overheat and cause permanent damage to the CT.

**CT flux linking**

Looking at flux from the primary conductor, we assume that all flux links into the core with very little difficulty, with a negligible amount leaving the core (see figure 5). We refer to this as a low leakage flux design. We also assume the primary conductor is straight with no other external fields present. When CTs are in close proximity to a bend in the conductor, or close to its return conductor, the flux can enter the core at different angles and magnitudes (see figure 6). Positioning the CT window on the conductor can also impact how flux enters the core (see figure 7). Though not ideal, such orientations may have a minor impact on normal CT performance.

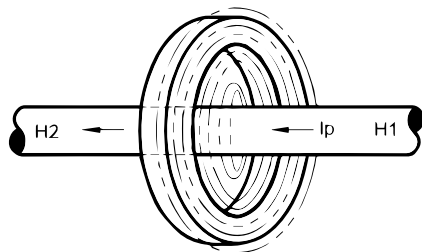

— 05

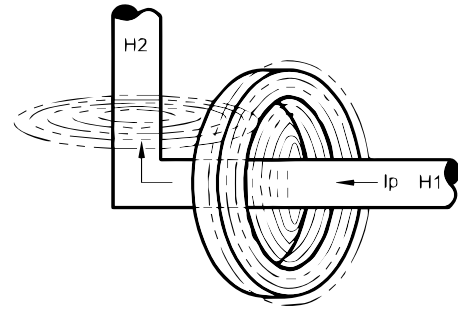

— 06

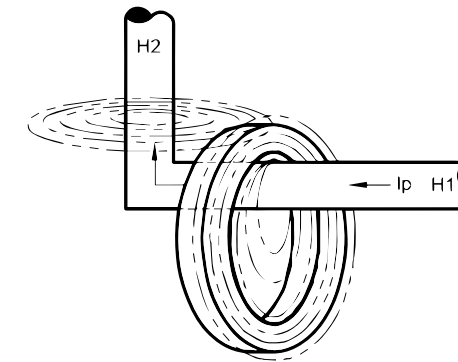

— 07

Depending on the magnitude of primary current, a configuration as shown in figure 6 can create a situation whereby a portion of the core becomes saturated. We refer to this as localized core saturation. This is where the external flux impedes the working flux in the CT core. Since this is a result of flux from portions of the conductor not passing through the CT window, we refer to this flux as stray flux.

Power systems traditionally have three equally spaced conductors. Assuming the conductors are straight, they have little impact on CT working flux (see figure 8). Bus geometry plays an important role in flux linking. Placement of CTs is also crucial to their performance in certain bus configurations.

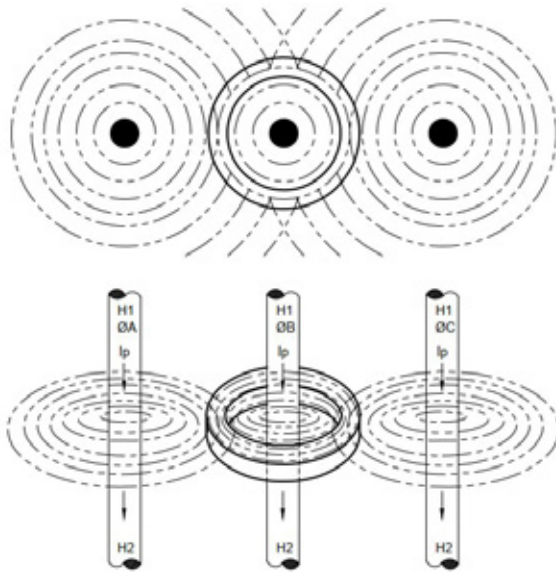

Looking into the core and conductors in figure 8, we can see how flux lines from adjacent conductors cut into the core. This external flux linking occurs all the time in three-phase systems, but the CTs still function. Why?

The magnitude of stray flux plays a major role. Field strength or magnetizing force in air is related to the current flowing in the conductor and is inversely proportional to the distance away from that conductor, a relationship known as the Biot-Savart Law:

$$H = I / 2\pi r$$

where:

I is current, in amperes

r is distance from current source, in meters

In practice, the working flux in the core under normal operating conditions is more dominant than the external stray flux entering the core, so the external stray flux is, therefore, negligible. At some point, the stray flux becomes more dominant, such as during fault events in which currents are ~15x and higher, or when the magnitude of primary current is tremendously high, as in generators.

### CTs in large AC generators

Large AC generators are rotating machines that require a source of mechanical energy to turn the prime mover, which rotates the turbine. This can be renewable forms, such as wind or water, fossil fuels, such as gas, oil or coal, or nuclear fission.

Renewables are a source for the prime mover, but the others are fuel sources that create steam, which becomes the prime mover. Today, nearly 80% of the world's power is produced from steam turbines.

These machines come in various sizes ranging from 1 megawatt (MW) to about 1500 MW. On smaller machines, CTs are installed inside terminal enclosures that may rest on top of the generator frame. In larger machines, the CTs are mounted on the lead terminals just before the isolated-phase bus (IPB) connection. The IPB is a set of special current-carrying conductors carefully constructed to minimize stray magnetic flux created by the high currents flowing through the conductors. In either case, they are subjected to some degree of continuous vibration. Construction of the CT must endure this vibration, so an adequate means for anchoring the CT assembly to the frame or enclosure is necessary. Materials used are of higher thermal and mechanical grade for durability and long-term service. To differentiate this type over conventional BCTs used in power transformers and circuit breakers, we will refer to them as generator-class BCTs, or simply GCTs.

—  
 09 Cross-section of large  
 AC power generator  
 —  
 10 3-phase LINE and  
 NEUTRAL flux linking

### Location of GCTs

Figure 9 shows a cutaway view of a typical large generator and where GCTs may be physically located.

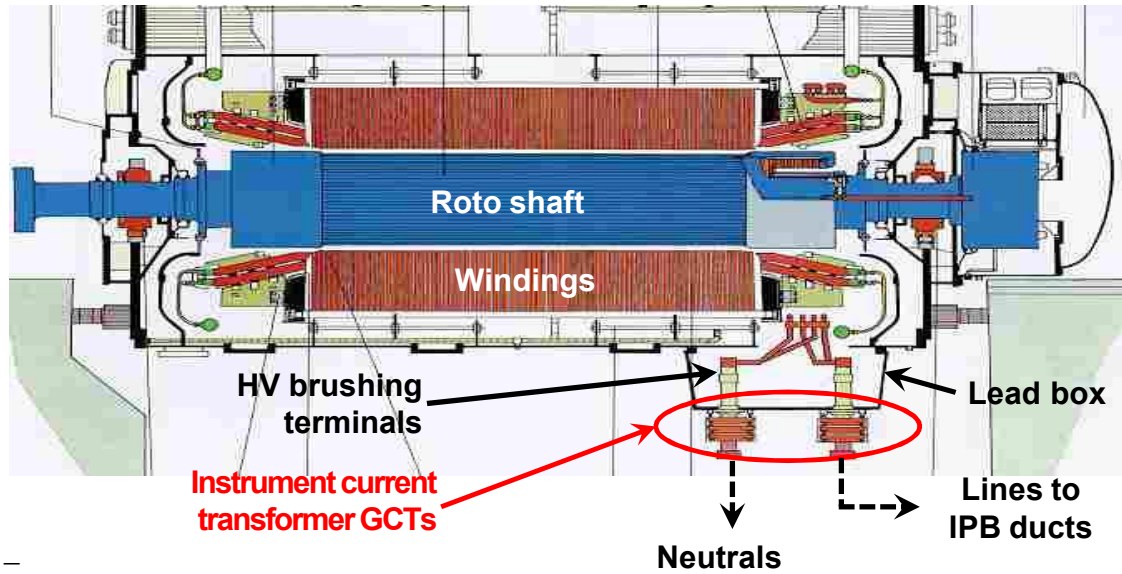

—  
 09

Because this is a rotating machine, GCTs are subjected to very strong magnetic fields. This can present challenges thermally, mechanically and operationally. We have seen how CTs interact on primary conductors and how placement is critical, but on terminal bushings hanging from the generator lead box, GCTs are mounted in very close proximity to the lead box enclosure. On the other side is a network of stator winding leads crossing over to terminate to their appropriate terminals. This creates a source of tremendous stray flux from all conductors, which interacts with the GCT core (see figure 10). To further complicate the matter, the LINE and NEUTRAL terminals are all in very close proximity to one other. The magnitude of current passing through these terminals can range from a few thousand up to about 45,000 amps at varying distances.

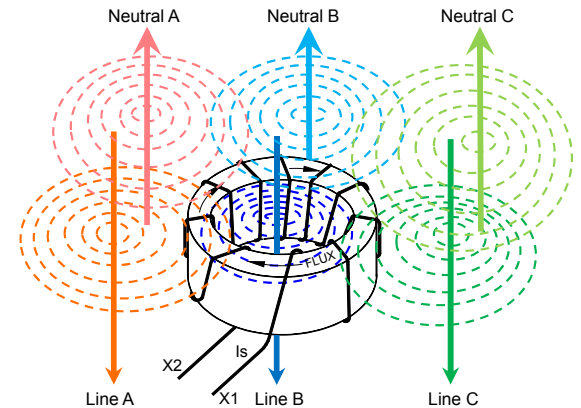

—  
 10



- 14 GTE on top of generator (top), CT and bus assembly that is installed inside the GTE (bottom)
- 15 Aluminum casing with cooling fins
- 16 Copper casing with cooling fins



—  
14

The GTEs are used for lower current ratings (<12 kA) with LINE to NEUTRAL spacings farther apart. This lends to lower stray flux fields. But CTs may be larger in physical size because of the air clearances needed to achieve system dielectric ratings. Bus geometry may be round or rectangular depending on the OEM's preference.

To handle these extremely high stray flux fields, the secondary coil is uniquely designed with an integral shield winding. It is specifically engineered to dissipate heat from high induced currents, while at the same time balancing stray flux in the core to ward off localized saturation in the GCT. The benefit is to prevent erroneous operation of the protective control device or prevent incorrect readings for revenue metering purposes.

**The evolution of GCT secondary coil design**

A different form of magnetic shielding was used on early machines, and this evolved as machines were made larger to accommodate growing demands. Back in the early days, engineers learned the hard way about how stray flux influenced CT operation, and that the center phase terminal always ran hotter than the outer phase terminals (and still does today). But they had to figure out ways to overcome these issues.

In the 1940s, General Electric and Westinghouse Electric — who, incidentally, also manufactured generators — produced many coils potted in sand-cast aluminum shells. These cast shells were large, heavy and very costly, but were needed to permit the CT to operate uninfluenced in high stray flux fields. The cores were oversized with much core cross section used. To help with heat, Westinghouse added cooling fins as early as 1961 (see figure 15).



—  
15

These cast-shell CTs were suspended from the generator lead box around the terminal bushings, in stacks of two to four CTs per terminal. During normal operation, high eddy currents circulated in the shells and through the mounting bolts in multiple current loops, causing the casings to run hot, in some cases as high as 110 °C at the surface in the center phase, and a bit cooler in the outer phases. It was observed that units ran hotter when adjacent to the lead box enclosure, and cooler farther away. It was for this reason that as early as 1961, Westinghouse began using copper shells exclusively in the center phase position (see figure 16). Copper, though heavier than aluminum, allowed for better thermal conductivity, or the ability to handle and dissipate more heat. The cooling fins ran along the outer diameter of the shell. Some casings even included water lines to provide for additional cooling.



—  
16



Stray flux phenomena spawned many articles published in the early 1950s, when it became a more relevant issue that warranted much research. Researchers learned about CTs operating in very close proximity to high magnetic fields. The casings in conjunction with over-sized cores did overcome most of the stray flux influence but not the adverse heating effects. Once the problem and its effects were identified, possible solutions emerged, most notably the use of compensating windings (see figure 17).

**ABB’s shield winding design**

In 1976, Duke Power consulted with Associated Engineering Company (now part of ABB) regarding a study on the influence of high flux fields on CTs mounted on generator terminals. Utilities were experiencing erroneous CT readings under certain conditions, causing false trips. Extensive studies confirmed that stray flux was the culprit. In collaboration with generator makers GE and Westinghouse, Associated Engineering developed a method to control this influence using compensating windings and, at the same time, designed a lightweight, more compact and lower cost CT than was used previously. What evolved from that collaboration is what we refer to today as shield winding.

The shield winding design used by ABB is a combination of series-parallel segmented windings configured in a proprietary manner so as to balance the stray flux throughout the entire core, each segment having a fixed number of turns. The shield itself is an integral part of the main winding, meaning that it shares the same secondary current. The shield windings are capable of handling very high circulating currents induced from the external stray flux fields. This added current cancels electrically and does not add to the nominal secondary current. However, this induced current is real and does produce heat in the shield windings that must be dissipated. Over the years, ABB encountered circumstances that have presented unforeseen challenges, enabling the company to continually adapt and modify the shield for unusual conditions — an evolving work in process.

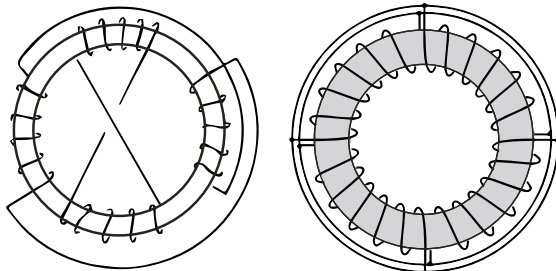

To follow the lineage of this evolution, we must trace its roots. Associated Engineering was formed in the early 1950s as a collaboration of independent engineers. They became well respected in the power industry as an innovator and developed a wide range of instrument transformers servicing utilities. In 1978, Associated Engineering was acquired by Kuhlman Electric Corporation and continued to operate as a wholly owned subsidiary. The first GCT incorporating this new shield winding technology was marketed and sold in 1980 as just a coil (GCT-802) used in IPB. In 1984, this same shielded coil was secured to a rigid mounting board (GCT-848) to facilitate easy mounting onto the bushing terminals. In 1994, Associated Engineering was closed with its products integrated into Kuhlman facilities. The dry and molded products were sent to Versailles, KY, which included the GCT models. In 2008, ABB acquired Kuhlman Electric and, two years later, integrated those products into its Pinetops, NC, facility, where they are produced today. These products are made exclusively in the USA and sold globally.

ASSOCIATED ENGINEERING COMPANY  
ANNOUNCEMENT

SHIELDED DESIGN GENERATOR  
CURRENT TRANSFORMERS

September 1981



SHIELDED DESIGN GENERATOR  
CURRENT TRANSFORMERS

Associated is proud to announce Shielded Design Generator CT's with configurations for both outdoor and indoor applications.

Shielded design generator CT's, another Associated development, are designed to limit the effect of stray flux on transformer accuracy, particularly at high fault current levels.

These new designs are computer optimized to provide maximum shielding from adjoining phases. The effectiveness of the shielding system has been computer-verified through 400 times rated current.

This product line of generator CT's includes primary current levels from 6000:5 to 45000:5 and designs through 62" inside diameter.

The unique computer optimized shielding system should be utilized anytime the nameplate rating of the transformer is 15000 amperes or above, depending on phase spacing. Both metering and relaying accuracies are available as engineered designs for each specific application.

These transformers play a vital roll in control and monitoring systems for generation stations. In fact, they are the first line of defense and protection for generators when applied directly to the output bushings of the unit. Many times multiple sets of CT's are applied here to provide different monitoring needs and backup protection we are all so aware of.

Also, many areas from the generator through the isolated phase bus system to the step up transformer are the most frequent application of these products.

We are proud to announce this offering of a new higher technology product, the Shielded Design Generator Current Transformer, to the family of Associated Engineering Company products.

—  
19 Evidence of resin  
leaking seen on outer  
walls of CT casings  
—

20 Resin leaking  
from top CT  
—

21 Resin blistering  
from excessive heat  
—

Each ABB GCT that incorporates a shield winding is thoroughly tested to ensure that (a) the shield segments have correct turns, (b) the inter-connections are correctly made, (c) the shield segments are correctly positioned, and (d) the CT rated accuracy is maintained through rated current when subjecting it to a simulated high stray flux condition.

#### Issues with potted-casing CTs

We know that stray flux produces heat, directly or indirectly. Metallic materials with iron as their main ingredient can become magnetized in the presence of magnetic fields. Non-ferrous materials, such as aluminum, copper, lead and brass, are considered non-magnetic. But none of these materials are impervious to eddy currents, which are circulating currents that produce their own magnetic fields. Even though non-ferrous materials cannot become magnetized, they can circulate eddy currents in the presence of high magnetic fields such as those found in large generators. Eddy currents, if high enough, will produce significant resistive ( $I^2R$ ) heating.

Over time, the old potted-casing CTs ran hot. These casings are known to have been subjected to temperatures near 110 °C for long periods of time. Located in an area with limited or no air flow, they have no effective cooling. Over time, the potting compound decomposes, and when that happens, failure is imminent. Signs of this can be seen on the exterior of these casings.



—  
20

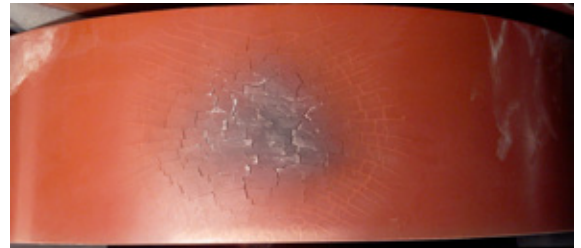

—  
21

Figures 19 and 20 are examples of potting compound failure. In all instances, the resin appears to be coming from the topmost CT closest to the lead box. In figure 21, we see the exterior of a potted unit, which has no outer casing, blistering from excessive heat. In this example, stray flux, not eddy currents, is the culprit, creating high induced currents in the secondary winding.

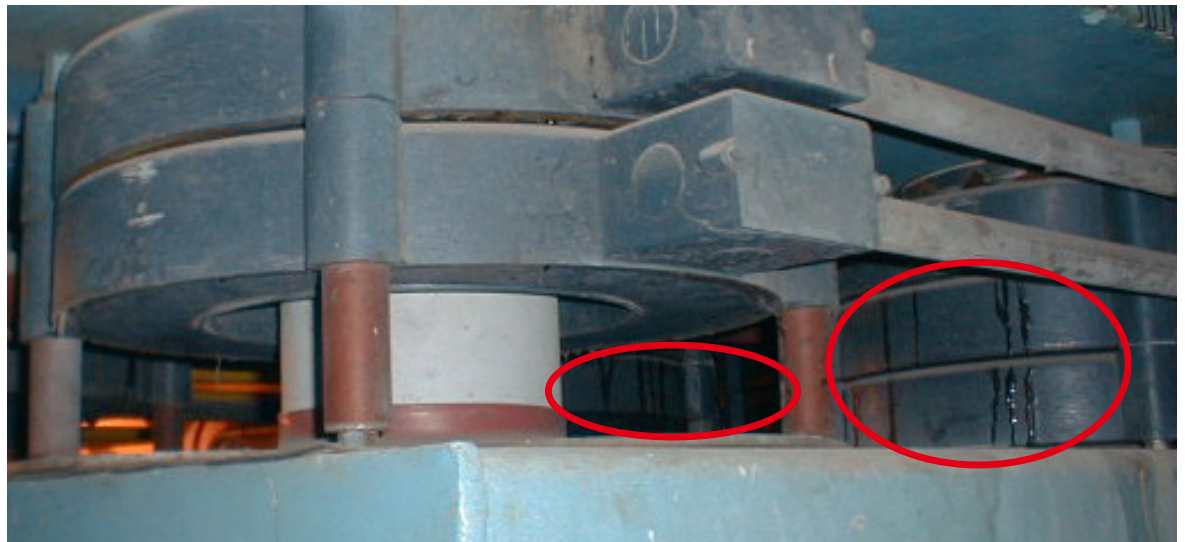

—  
19

- 22 Potting top surface showing signs of heat
- 23 Broken secondary lead wire
- 24 Damage done by open-circuited CT disintegrated
- 25 Secondary terminals damaged by open circuit voltage

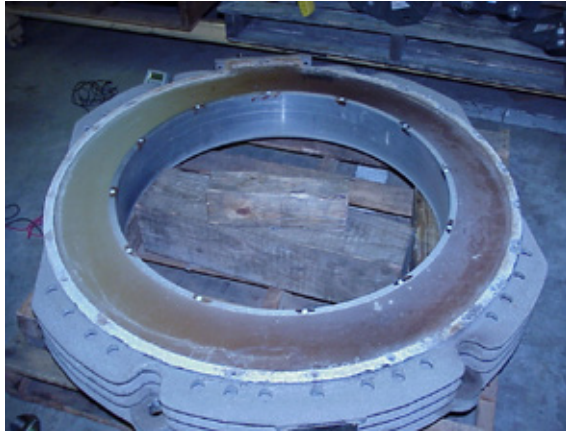

—  
22

Many investigations over the years involving potted-casing CTs have shown that when potting compound breakdown is not visible from the outside, it can be seen on the inside with the removal of the outer cover. The discoloration of the potting compound is noticeable, and the location is predictable, as seen in figure 22. What ultimately happens because of the potting compound breakdown is a shift in the coil that puts it in direct contact with the casing, thus shorting the winding to ground.

These potted CTs have another weakness, the flexible secondary lead wire. We have seen situations in which the exit lead insulation of the secondary winding breaks, exposing the connection, and in some cases, the entire lead separates. This creates a potential for open circuiting the secondary winding, which may lead to a catastrophic event. If the lead breaks at the point of exit, the entire CT must be replaced.



—  
23

This is a serious matter for many reasons. Under no circumstance should any CT ever have its secondary winding open while its primary conductor is

energized. If this happens, all the available primary ampere-turns are consumed by the core, driving it into hard saturation. The result is an extremely high, and possibly lethal, peak voltage developed in the secondary winding. Keep in mind, no current is flowing in the secondary. This will subject the coil to tremendous dielectric stress that will likely lead to coil failure. At the secondary terminals, where voltage will be the highest, an arc may occur across the terminals, or between a terminal and its junction box, which may be grounded. Either case creates high potential for external damage in the immediate area. Figures 24 and 25 show examples of such damage. In this instance, the event was due to a loose connection. Once the CT winding has been permanently damaged, it must be replaced.



—  
24



—  
25

### Specifying GCTs today

Many large AC generators in service today are well over 40 years old. Sometimes these machines are taken out of service for routine maintenance, or to be overhauled and updated. In many cases, the original CTs may or may not be inspected in detail unless the reason for maintenance is specifically

to do so. More than likely, the original CTs are no longer manufactured or even available in their original form, because, in most cases, the CT OEM is no longer in business.

Newer GCTs come in two varieties today, board-mounted or solid-cast. When specifying, all new GCTs should be designed with shield windings, be of rugged construction to withstand vibration and be capable of limiting water ingress from rain or hose-sprayed water. They should also provide some degree of protection from dust, dirt, sand and condensation. GCTs should never be submerged in water, nor exposed to the elements directly unless they are rated for outdoor exposure. In some instances, newer GCTs may be shorter in height and lighter in weight than the older GCTs they are replacing. They are still subjected to higher operating ambient temperatures, so should have a minimum insulation class of 130 °C. Selection of current ratio is typically 112%–125% of the machine's rated continuous current, rounded to an even number, with a 5 A rated secondary winding. Multiple winding machines may use 2.5 A windings that are eventually paralleled. Some older GCT designs, usually of higher current ratio, were fitted with a test tap to facilitate a means to test the GCT by using the test winding to induce current into the other winding. Test windings, if desired, must be specified.

Special features may include some degree of protection from hazardous environments. Many of these machines are hydrogen cooled, so there is always concern about hydrogen leaking and causing a destructive fire. GCT windings are inherently safe from emitting electrical arcs that could ignite hydrogen. Usually, an arc will occur at the secondary terminals due to a loose connection that will open the secondary winding (refer to figures 23 and 24). This is a potentially dangerous situation and must be avoided. Optional explosion-proof junction boxes may be employed. All externally connected conduit runs must be in full compliance with the National Electrical Code (NEC) or other international equivalent wiring code for the zone of protection needed.

Certifications from UL, CSA or CE are not customarily required for GCTs due to the application and accessibility during service. Even 1-E certification for nuclear use is not customarily required for these

products. Such certifications can be very costly to obtain in comparison to the value they would add. GCTs should always comply with IEEE and IEC standards, as applicable, and may be subject to additional utility requirements when specified. All CTs should meet the minimum routine factory tests as prescribed in the referenced standard.

### **GCT testing**

Regarding type testing, ABB GCTs fully comply with IEEE and IEC standards concerning the basic tests required. Additional tests not in the standard are also of utmost importance. These include rain/spray tests, vibration tests and stray flux testing. Many of these requirements were part of the original GE and Westinghouse specifications. Even though they no longer make CTs or generators, they have licensed their designs to other OEMs, particularly in China and other Far East countries, such as Harbin, Shanghai Turbine, Alstom, Toshiba, Hitachi and Mitsubishi. It is important that the buyer understand the compliance of the GCTs being used in these machines.

Commissioning and acceptance testing after installation may be performed by the installer or a third-party testing service. This, too, should be done in accordance with IEEE standards for field testing. Generator-class CTs are sometimes more difficult to test than conventional CTs on transformers and breakers, mainly due to their current ratio, physical size and installed location. Many will have high excitation requirements that surpass the capabilities of most portable test sets commonly used. Attention must be taken as to how the test set functions and its limitations. When in doubt, consult with the GCT OEM for guidance.

### **Conclusion**

The last thing a utility wants is a GCT failure causing an unexpected service outage. Besides the other challenging issues associated with this event, it will likely be difficult to find a replacement GCT in a timely manner. The odds of any GCT OEM having a unit in the size and current ratio needed is very slim. This alone makes the strong case for a robust preventative maintenance program that includes a sound GCT inspection.