

---

ABB WIND TURBINE CONVERTERS

# **ACS880-87CC wind turbine converters**

## Hardware manual





# ACS880-87CC wind turbine converters

Hardware manual

Table of contents



1. Safety instructions



4. Mechanical installation



6. Electrical installation







# Table of contents

---

## 1 Safety instructions

Contents of this chapter .....	11
Use of warnings and notes .....	11
General safety in installation, start-up and maintenance .....	12
Electrical safety in installation, start-up and maintenance .....	14
Precautions before electrical work .....	14
Additional instructions and notes .....	15
Fiber optic cables .....	15
Opening and disconnecting the main circuit breaker .....	16
Disconnecting the charging circuit from the main circuit .....	18
Disconnecting the auxiliary power supply .....	19
Grounding .....	20
Work on the liquid cooling system .....	21

## 2 Introduction to the manual

Contents of this chapter .....	23
Target audience .....	23
Categorization by frame size and option code .....	23
Quick installation, commissioning and operation flowchart .....	24
Terms and abbreviations .....	25
Related documents .....	26

## 3 Operation principle and hardware description

Contents of this chapter .....	27
Operation principle .....	27
Generator control .....	28
Overview diagram of the wind turbine converter .....	29
Single converter .....	29
Parallel converters .....	30
Layout drawing .....	31
Overview of power and control connections .....	34
Single converter .....	34
Parallel converters .....	35
Circuit boards .....	36
Single converter .....	36
Parallel converters .....	37
BAMU board .....	39
Type designation labels .....	39
Single converter .....	39
Parallel converters .....	40
Type designation key .....	41
Basic code .....	42
Option codes (plus codes) .....	42

---

**4 Mechanical installation**

Contents of this chapter .....	45
Safety instructions .....	45
Checklist before mechanical installation .....	46
Moving the converter package .....	47
Moving the converter package by fork-lift .....	47
Moving the converter on rollers .....	47
Unpacking .....	48
Lifting the converter .....	48
Placing the converter .....	50
Fastening the cabinet to the floor .....	51
Internal cooling circuit .....	51
Lifting the door .....	51
Miscellaneous .....	51
Cable duct in the floor below the cabinet .....	51
Electric welding .....	51

**5 Planning the electrical installation**

Contents of this chapter .....	53
Selecting the grid disconnecting device .....	53
Checking the compatibility of the generator and the converter .....	54
Protecting the generator insulation and bearings .....	54
Selecting the power cables .....	55
General rules .....	55
Sufficient conductivity of the protective conductor .....	55
Typical power cable sizes .....	56
CE cables .....	56
UL cables .....	57
Alternative power cable types .....	57
Power cable types for limited use .....	57
Not allowed power cable types .....	58
Generator cable shield .....	58
Single core vs multicore cables in grid cabling .....	58
Additional US and Canada requirements .....	59
Conduit .....	59
Armored cable / shielded power cable .....	59
Selecting the control cables .....	59
General rules .....	59
Relay cable .....	60
Routing the cables .....	61
Control cable ducts .....	62
Protecting the converter installation .....	62
Protecting the grid cable in short-circuit situations .....	62
Protecting the generator and generator cable in short-circuit situations .....	62
Protecting the converter, generator cable and grid cable against thermal overload ...	62
Protecting the converter against ground faults in the generator or generator cable ...	62
Protecting the converter against ground faults in the converter or grid cable .....	63
Implementing the emergency stop function .....	63
Implementing the grid fault ride-through function .....	63
Supplying power for the auxiliary circuits .....	63
Using a safety switch between the converter and generator .....	63



Protecting the contacts of relay outputs .....	63
<b>6 Electrical installation</b>	
Contents of this chapter .....	65
Checking the insulation of the assembly .....	65
Converter .....	65
Grid cable .....	65
Generator stator and generator cable .....	66
Connecting the grid cables .....	66
Connection diagram .....	66
Connection procedure .....	67
Connecting the generator cables .....	68
Connection diagram .....	68
Connection procedure .....	68
Connecting the external power supply cable for the auxiliary circuit .....	71
Connecting the control cables .....	72
Default I/O connection diagrams .....	72
<b>7 Installation checklist</b>	
Contents of this chapter .....	73
Before you start .....	73
Checklist .....	74
<b>8 Maintenance</b>	
Contents of this chapter .....	75
Maintenance intervals .....	75
Maintenance timers and counters .....	77
Cabinet .....	77
Cleaning the door air inlets .....	77
Cleaning the door air inlets and outlets (auxiliary control cubicle) .....	78
Cleaning the outlet (door or roof) filters .....	78
Power connections .....	78
Tightening .....	78
Fans .....	79
Replacing the cooling fan of the converter module .....	79
Replacing the fan of the main breaker cubicle .....	81
Replacing the cooling fan of the auxiliary control cubicle .....	82
Replacing the cooling fan of the LCL filter cubicle .....	83
Fuses .....	84
Replacing the DC fuses .....	84
Replacing the AC fuses .....	85
Converter module .....	86
Replacing the converter module .....	86
Capacitors .....	92
BCU control unit .....	92
Replacing the memory unit .....	92
Replacing the real-time clock battery .....	92
Replacing the SD/SDHC memory card .....	92
Replacement illustration .....	93
Main circuit breaker .....	93



**9 Technical data**

Contents of this chapter .....	95
Ratings .....	95
Definitions .....	95
Derating .....	96
Ambient temperature derating .....	96
Altitude derating .....	96
Type equivalence table .....	96
Fuses .....	97
Main circuit AC fuses .....	97
Main circuit DC fuses .....	97
Fuses for the voltage measurement board BAMU .....	97
Fuses of the DC chopper .....	97
F4 fuses .....	97
Dimensions, weights and free space requirements .....	97
Losses, cooling data and noise .....	98
Internal cooling circuit data .....	98
Terminal and lead-through data for the grid connection .....	98
Tightening torques .....	98
Terminal and lead-through data for the generator cable .....	98
Grid specification .....	99
Requirements for the grid connection .....	99
Generator connection data .....	99
BCU control unit .....	99
Efficiency .....	100
Degree of protection .....	100
Environmental and corrosion classification .....	100
Ambient conditions .....	101
Materials .....	102
Auxiliary circuit current consumption .....	102
Applicable standards .....	103
CE marking .....	103
Compliance with the European Low Voltage Directive .....	103
Compliance with the European EMC Directive .....	103
Compliance with the European Machinery Directive .....	103
Regulatory Compliance Mark (RCM) .....	103
EAC (Eurasian Conformity) marking .....	104
Compliance with EN 61800-3:2004/A1:2012 .....	104
Definitions .....	104
Category C4 .....	104
ETL marking .....	105
WEEE mark .....	105
GL2010 .....	105
Disclaimers .....	105
Generic disclaimer .....	105
Cybersecurity disclaimer .....	105

**10 BCU-x2 control unit**

Contents of this chapter .....	107
General .....	107
BCU control unit .....	107

Layout and connections .....	108
Connector data .....	110
<b>11 BCU-x5 control unit</b>	
Contents of this chapter .....	113
General .....	113
BCU control unit .....	113
Layout and connections .....	114
Connector data .....	117
<b>12 Dimension drawings</b>	
Contents of this chapter .....	119
<b>13 Cooling and heating</b>	
Contents of this chapter .....	123
Hardware description .....	123
General .....	123
Diagram of the internal cooling and heating circuit .....	123
Planning the cooling system .....	125
Connection to a cooling unit .....	125
General requirements .....	125
Coolant temperature control .....	125
Mechanical installation .....	126
Connecting the internal cooling circuit to a customer cooling unit .....	126
Connecting the liquid pipes .....	126
Filling up and bleeding the internal cooling circuit .....	126
Converters with a customer cooling unit .....	127
Draining the internal cooling circuit .....	128
Cooling station control .....	128
Specifications .....	129
Temperature limits .....	129
Pressure limits .....	130
Water quality .....	130
Freeze protection and corrosion inhibition .....	130
Coolant concentration .....	131
Coolant mixture quality .....	131
Approved coolants .....	131
Materials .....	131
Cold start .....	132
First start in a commissioning .....	132
Normal start and start after blackout .....	132

*Further information*

---



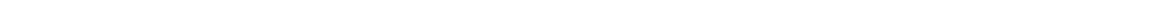

# 1

## Safety instructions

---



### Contents of this chapter

This chapter contains the safety instructions which you must obey when you install and operate the converter, and do maintenance on the converter. If you ignore the safety instructions, injury, death or damage can occur to the converter, the generator or other adjoining equipment. Read the safety instructions before you work on the unit.

### Use of warnings and notes

Warnings tell you about conditions which can cause injury or death, or damage to the equipment. They also tell you how to prevent the danger. Notes draw attention to a particular condition or fact, or give information on a subject.

The manual uses these warning symbols:

**WARNING!**

Electricity warning tells about hazards from electricity which can cause injury or death, or damage to the equipment.

---

**WARNING!**

General warning tells about conditions, other than those caused by electricity, which can cause injury or death, or damage to the equipment.

---

**WARNING!**

Electrostatic sensitive devices warning tells you about the risk of electrostatic discharge which can cause damage to the equipment.

---

## **General safety in installation, start-up and maintenance**

These instructions are for all personnel that install the converter and do maintenance work on it.





**WARNING!**

Obey these instructions. If you ignore them, injury or death, or damage to the equipment can occur.

- Use safety shoes with a metal toe cap. Use protective gloves.
- Use protective eyewear when working with the liquid cooling system.
- Handle the converter modules carefully:
  - Lift the module with a lifting device only. Use the designated lifting points. See the lifting instructions.
  - Do not tilt the module. It will overturn very easily because it is heavy and its center of gravity is high.
  - Modules running on wheels: Make sure that the module does not topple over when you move it on the floor: Whenever possible secure the module also with chains. Do not leave the module unattended on a sloping floor.
- Beware of hot surfaces. Some parts, such as heatsinks of power semiconductors, remain hot for a while after disconnection of the electrical supply.
- Keep the converter in its package or protect it otherwise from dust and burr from drilling and grinding until you install it. Protect also the installed converter against dust and burr. Electrically conductive debris inside the drive can cause damage or malfunction.
- Vacuum clean the area below the converter before the start-up to prevent the converter cooling fans from drawing the dust inside the converter.
- Do not cover the air inlet and outlet when the converter is running.
- Make sure that there is sufficient cooling. Before power switch-on, make sure that the liquid cooling circuit is filled up with coolant. Running the external cooling pump dry will damage it. Also the converter will not cool down. See the converter hardware manual.
- Before you connect voltage to the converter, make sure that the cabinet doors are closed. Keep the doors closed during operation.
- Before you adjust the converter operation limits, make sure that the generator and all driven equipment can operate throughout the set operation limits.
- The maximum number of converter power-ups is five in ten minutes. Too frequent power-ups can damage the charging circuit of the DC capacitors.
- Make sure that safety circuits (for example, emergency stop, if any) are validated at start-up.
- Beware of the cooling fan blades. The fans can continue to rotate for a while after the disconnection of the electrical supply.
- Service the main circuit breaker once a year. If not serviced, damage can occur to the wind turbine.

**Note:**

- Only authorized persons are allowed to repair a malfunctioning converter.

## Electrical safety in installation, start-up and maintenance

### ■ Precautions before electrical work

These instructions are for the qualified electricians who do work on the converter, generator cable or generator.



#### **WARNING!**

Obey these instructions. If you ignore them, injury or death, or damage to the equipment can occur. If you are not a qualified electrical professional, do not do electrical installation or maintenance work. Do these steps before you do installation or maintenance work.

---

1. Clearly identify the work location.
2. Disconnect all possible voltage sources.
  - Open the main circuit breaker (Q1), disconnect, lock and attach a warning notice to it. See section *Opening and disconnecting the main circuit breaker (page 16)*.
  - Open the charging circuit switch-disconnector (Q10). See section *Disconnecting the charging circuit from the main circuit (page 18)*.
  - Open and lock out the auxiliary voltage switch-disconnector (Q2). See section *Disconnecting the auxiliary power supply (page 19)*.
  - Disconnect any external dangerous voltages from the control circuits (such as relay outputs).
  - Open, disconnect and lock out the breaker of the grid transformer as the main circuit breaker of the converter does not remove the voltage from the grid cable busbars and some auxiliary circuits. Attach a warning notice to the disconnector.
  - Lock the turbine rotor (and generator shaft).
  - Open the safety switch between the generator-side converter and the generator (if any).
  - After you disconnect the converter, always wait for five minutes to let the intermediate circuit capacitors discharge before you continue.
3. Protect any other energized parts in the work location against contact.
4. Take special precautions when close to bare conductors.
5. Measure that the installation is de-energized.
  - Use a multimeter with an impedance of at least 1 Mohm.
  - Make sure that the voltage between the converter grid cable terminals (L1, L2, L3) and the grounding (PE) busbar is close to 0 V.
  - Make sure that the voltage between the generator cable terminals (U2, V2, W2) and the grounding (PE) busbar is close to 0 V.
  - Make sure that the voltage between the DC bus and the grounding (PE) busbar is close to 0 V.



#### **WARNING!**

If the measurement requires removal or disassembly of shrouding or other cabinet structures, obey the local laws and regulations applicable to live working (including – but not limited to – electric shock and arc protection).

---

6. Install temporary grounding as required by the local regulations.
7. Ask the person in control of the electrical installation work for a permit to work.

### ■ Additional instructions and notes

---



#### **WARNING!**

Obey these instructions. If you ignore them, injury or death, or damage to the equipment can occur.

- If you are not a qualified electrician, do not do electrical installation or maintenance work.
- We do not recommend that you secure the cabinet by arc welding. If you have to, obey the instructions in the converter hardware manual.
- Do not do insulation or voltage withstand tests on the converter or converter modules.
- Control boards of the converter unit may be at the main circuit potential. Dangerous voltages can be present between the control boards and the frame of the converter unit when the main circuit voltage is on. It is critical that the measuring instruments, such as an oscilloscope, are used with caution and safety always as a priority. The fault tracing instructions give special mention of cases in which measurements may be performed on the control boards, also indicating the measuring method to be used.

#### **Note:**

- The generator cable terminals on the converter are at a dangerously high voltage when the converter is connected to the grid, regardless of whether the generator is running or not.
- The converter DC bus carries a dangerous voltage (over 500 V) when the converter is connected to the grid or when the generator shaft is rotating.
- External wiring can supply dangerous voltages to the terminals of relay outputs.



#### **WARNING!**

Use a grounding wristband when you handle printed circuit boards. Do not touch the boards unnecessarily. The boards contain components sensitive to electrostatic discharge.

### ■ Fiber optic cables

---



#### **WARNING!**

Obey these instructions. If you ignore them, equipment malfunction and damage to the fiber optic cables can occur.

- Handle the fiber optic cables with care.
  - When you unplug the cables, always hold the connector, not the cable itself.
  - Do not touch the ends of the fibers with bare hands as the ends are extremely sensitive to dirt.
  - Do not bend the fiber optic cables too tightly. The minimum allowed bend radius is 35 mm (1.4 in).
-

## ■ Opening and disconnecting the main circuit breaker

These instructions are for the qualified electricians who do work on the converter, generator cable or generator.

---



### **WARNING!**

If you are not a qualified electrician, do not proceed or do any installation or maintenance work.

---

1. Undo the two fastening screws of the main circuit breaker (Q1) cover.
2. Open the cover.
3. Open the cover of the red push button.
4. Push the red push button ("Push OFF").
5. Close both covers in front of the push buttons.
6. Lock the covers with a padlock. Put the key(s) in a safe place.
7. Make sure that the OPEN/CLOSED indicator shows OPEN.
8. Write your name, phone number and the date to the "Do not switch on. Men at work" warning sign and hang the warning sign on the main circuit breaker.



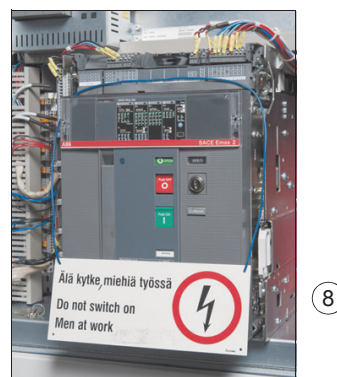
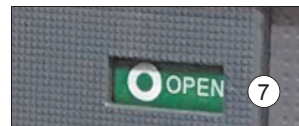
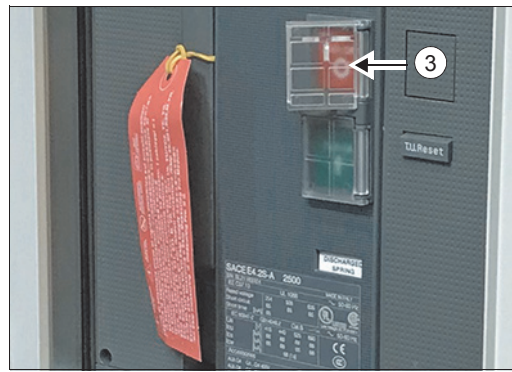
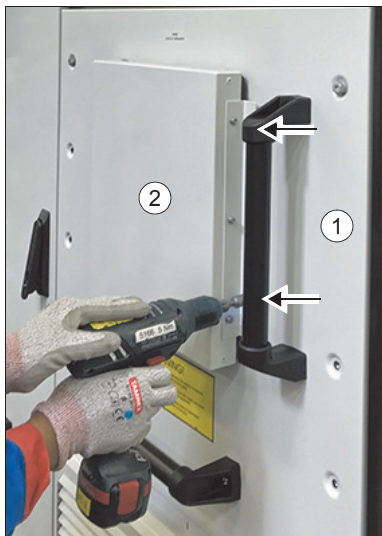

## ■ Disconnecting the charging circuit from the main circuit



### WARNING!

If you are not a qualified electrician, do not proceed.

1. Make sure that you have opened the main circuit breaker (Q1). See section [Opening and disconnecting the main circuit breaker \(page 16\)](#).
2. In the upper part of the main circuit breaker cubicle, turn the charging circuit switch (Q10) from ON position (2a) to the OFF position (2b).
3. Lock the charging circuit switch to the OFF position with a padlock. Stow the key(s) in a safe place.
4. Write your name, phone number and the date to the “Do not switch on. Men at work” warning sign and hang the warning sign to the charging circuit switch.

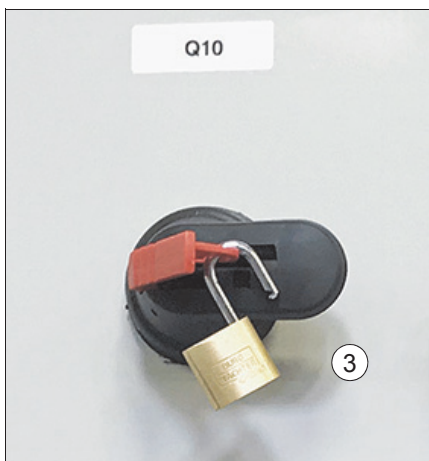



## ■ Disconnecting the auxiliary power supply



### WARNING!

If you are not a qualified electrician, do not proceed.

1. Make sure that you have opened the main circuit breaker (Q1). See section [Opening and disconnecting the main circuit breaker \(page 16\)](#).
2. In the upper part of the main circuit breaker cubicle, turn the auxiliary power supply switch (Q2) from ON position (2a) to the OFF position (2b).
3. Lock the switch Q2 to the OFF position with a padlock. Stow the key(s) in a safe place.
4. Write your name, phone number and the date to the “Do not switch on. Men at work” warning sign and hang the warning sign to the switch Q2.



## ■ Grounding

These instructions are intended for all who are responsible for the grounding of the converter.

---



### **WARNING!**

Obey these instructions. If you ignore them, injury or death, or damage to the equipment can occur, and electromagnetic interference can increase.

- If you are not a qualified electrician, do not do electrical installation or maintenance work.
- Always ground the converter, the generator and adjoining equipment to ensure personnel safety in all circumstances, and to reduce electromagnetic emission and interference.
- Make sure that the conductivity of the grounding conductors is sufficient. See the converter hardware manual. Obey the local regulations.
- In a multiple-converter installation, connect each converter separately to the protective earth (PE).

### **Note:**

- You can use power cable shields as grounding conductors only when their conductivity is sufficient.
  - As the normal touch current of the converter is higher than 3.5 mA AC or 10 mA DC, you must use a fixed protective earth connection. See standard IEC/EN 61800-5-1, 4.3.5.5.2..
- 





## Work on the liquid cooling system

These instructions are intended for all who are responsible for installation and maintenance work of the liquid cooling system of the converter.



### WARNING!

Obey these instructions. If you ignore them, injury or damage to the equipment can occur.

- Use protective eyewear when working with the liquid cooling system.
- Beware of hot liquid. Do not work on the liquid cooling system until the pressure is lowered down by stopping the pumps. High-pressure hot coolant (600 kPa, over 50 °C/122 °F) is present in the internal cooling circuit when the converter is in operation.
- Before power switch-on, make sure that the internal cooling circuit is filled up with coolant. Running the external cooling pump dry will damage it. Also the converter will not cool down.
- Avoid skin contact with coolant, especially antifreeze. Do not syphon them by mouth. If such substance is swallowed or gets into the eyes, seek medical advice.
- To avoid breaking the coolant pipes, do not overtighten the nuts of the unions.
  - Blue connectors: Leave 2...3 millimeters (0.08 ... 0.12 inches) of thread visible.

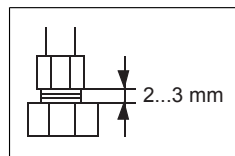

- Black connectors: Tightening torque is 10 N·m (7.4 lbf·ft) in room temperature (around +20 °C/68 °F).
- If the ambient temperature is below +5 °C (41 °F), add antifreeze and corrosion inhibitors to the cooling liquid.
- Drain the system before storing in temperatures below 0 °C (32 °F). Freezing of the liquid cooling system is not allowed. Operation at liquid temperatures below zero is not permitted, not even with antifreeze.



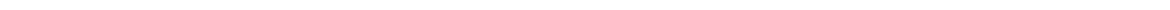



# Introduction to the manual

---

## Contents of this chapter

This chapter describes the intended audience and contents of the manual. It also contains a flowchart of steps in checking the delivery, installing and commissioning the wind turbine converter. The flowchart refers to chapters/sections in this manual and other manuals.

## Target audience

This manual is intended for people who plan the installation, install, commission, use and service the converter. Read the manual before working on the converter. The reader is expected to know the fundamentals of electricity, wiring, electrical components and electrical schematic symbols.

The manual is written for readers worldwide.

## Categorization by frame size and option code

This manual deals with the wind turbine converters made of the modules of the frame size R9iLC. The frame size of each converter type is indicated in the technical data.

The instructions, technical data and dimensional drawings which concern only certain optional selections are marked with + codes. The options included in the converter can be identified from the + codes visible on the type designation label. The + code selections are listed in section [Type designation key \(page 41\)](#).

---

## Quick installation, commissioning and operation flowchart

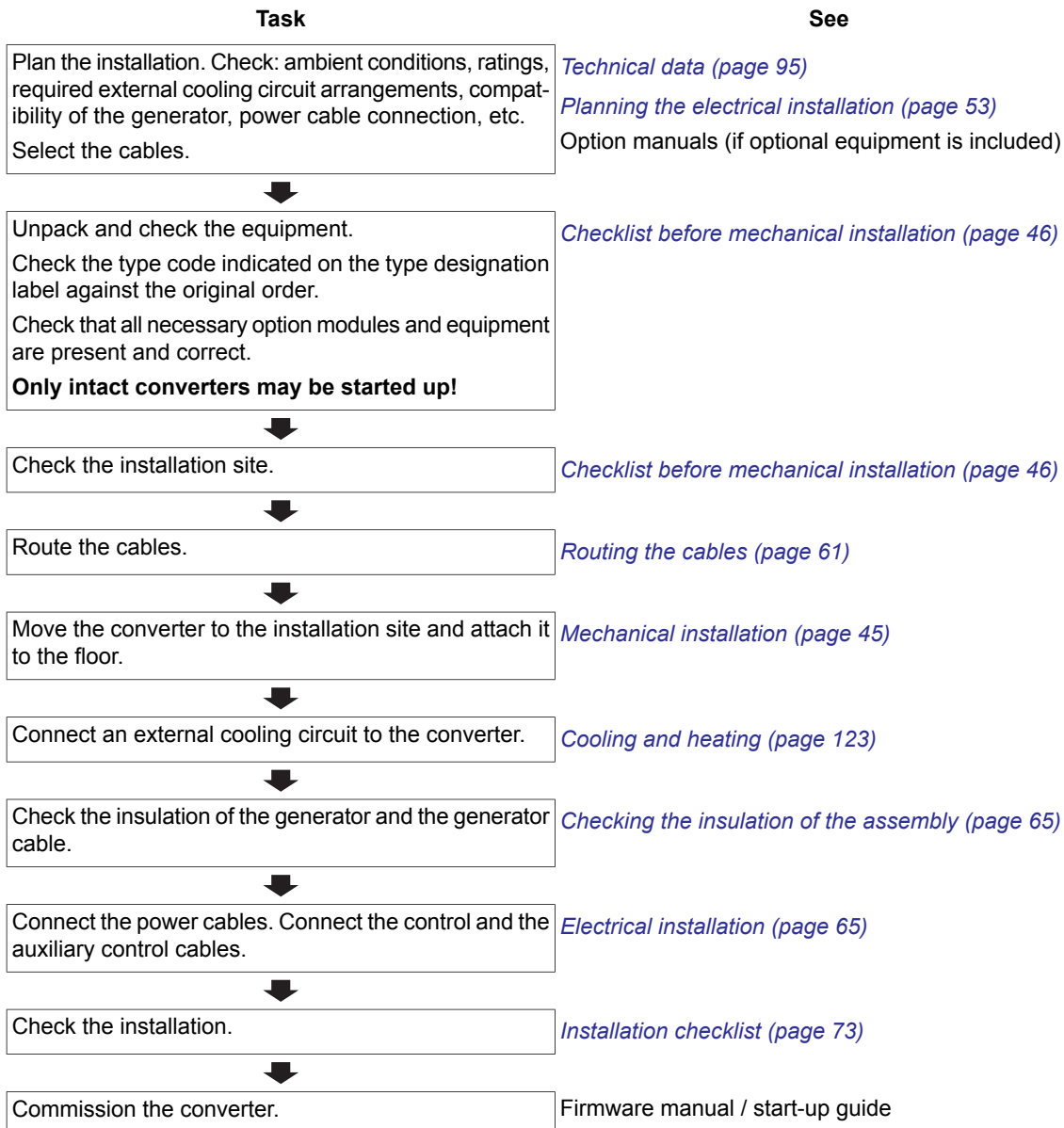

## Terms and abbreviations

Term	Description
ACU	Auxiliary control unit. Contains control electronics, auxiliary voltage circuitry, etc.
BAMU	Auxiliary measurement unit
BCON	Type of control board
BCU	Type of control unit
Control unit	The part in which the control program runs.
Converter	Converts direct current and voltage to alternating current and voltage, or vice versa.)
Converter module	Grid-side converter or generator-side converter module
Cubicle	One section of a cabinet-installed wind turbine converter. A cubicle is typically behind a door of its own.
DC chopper	Protects the converter by cutting down a peak overvoltage in the converter DC link: conducts the surplus energy from the intermediate circuit of the wind turbine converter to the DC resistor when necessary. The chopper operates when the DC link voltage exceeds a maximum limit. A sudden disturbance in turbine operation or grid can cause the DC voltage rise.
DC link	DC circuit between grid-side converter and generator-side converter
DC link capacitors	Energy storage which stabilizes the intermediate circuit DC voltage
DC resistor	Dissipates the surplus energy conducted by the DC chopper to heat. Essential part of the DC chopper circuit.
DDCS	Distributed drives communication system protocol
DTC	Direct torque control, a generator control method
EMC	Electromagnetic compatibility
FCAN	Optional CANopen® adapter module
FCNA	Optional ControlNet™ adapter module
FDNA	Optional DeviceNet™ adapter module
FEA-03	Optional I/O extension adapter
FEN-31	Optional HTL incremental encoder interface module
FENA	Optional Ethernet adapter module
FIO-01	Optional digital I/O extension module
FIO-11	Optional analog I/O extension module
FPBA-01	Optional PROFIBUS DP® adapter module
Frame, frame size	Physical size of the converter module, for example R9iLC.
Generator-side converter	The part of a wind turbine converter that is connected to the generator stator and transfers the generator-produced AC power to the converter DC bus
Grid-side converter	The part of a wind turbine converter that transfers energy from the converter DC bus to the AC grid and vice versa
IGBT	Insulated gate bipolar transistor
LCL filter	Inductor-capacitor-inductor filter
NETA-21	Remote monitoring tool
Parameter	In the control program, a user-adjustable operation instruction to the converter, or signal measured or calculated by the converter.
PE	Protective earth (ground)
PLC	Programmable logic controller
PSL	Power stage link
S500	I/O module
UPS	Uninterruptible power supply
Wind turbine converter	Converter between a wind turbine generator and the grid
Wind turbine system	Wind turbine system consists of the wind turbine, wind turbine converter, generator etc.
WTC	Wind turbine controller. Controls the whole wind turbine system.
ZMU	Type of memory unit, attached to the control unit

## Related documents

Name	Code
<b>General manuals</b>	
Drive/converter/inverter safety instructions	3AXD50000037978
ACS880-87CC wind turbine converters hardware manual	3AXD50000466948
ACS880-77LC/-87LC/-87CC wind turbine converters with WTA firmware manual	3AXD50000038874
ACS880-77LC/-87LC/-87CC wind turbine converters firmware manual	3AUA0000130879
ACS880-77LC/-87LC/-87CC wind turbine converters system description	3AXD50000022022
Emergency stop, stop category 0 (option +Q951) for ACS880-77LC/-87LC/-87CC wind turbine converters user's manual	3AXD50000040787
Drive composer start-up and maintenance PC tool user's manual	3AUA0000094606
Manuals and quick guides for I/O extension modules, fieldbus adapters, etc.	
<b>Other documents</b>	
Circuit diagrams set	
Fieldbus interface description	
Firmware release note with the download instructions	

For manuals, contact your local ABB representative.



# Operation principle and hardware description

---

## Contents of this chapter

This chapter describes the operation principle and the construction of the wind turbine converter.

## Operation principle

The ACS880-87CC is a four-quadrant, cabinet-mounted combined-cooled converter intended for full power conversion turbines with an induction generator or a permanent magnet generator. The converter is connected between the generator stator and the grid. The converter can be installed up in the nacelle or down on the ground level.

The converter consists of back-to-back connected cubicles that contain the grid-side converter modules, generator-side converter modules, LCL filter, terminals or grid busbars for grid cables and terminals for generator cables, internal control circuits, external control cable terminals, auxiliary circuits and external auxiliary power supply terminals.

---

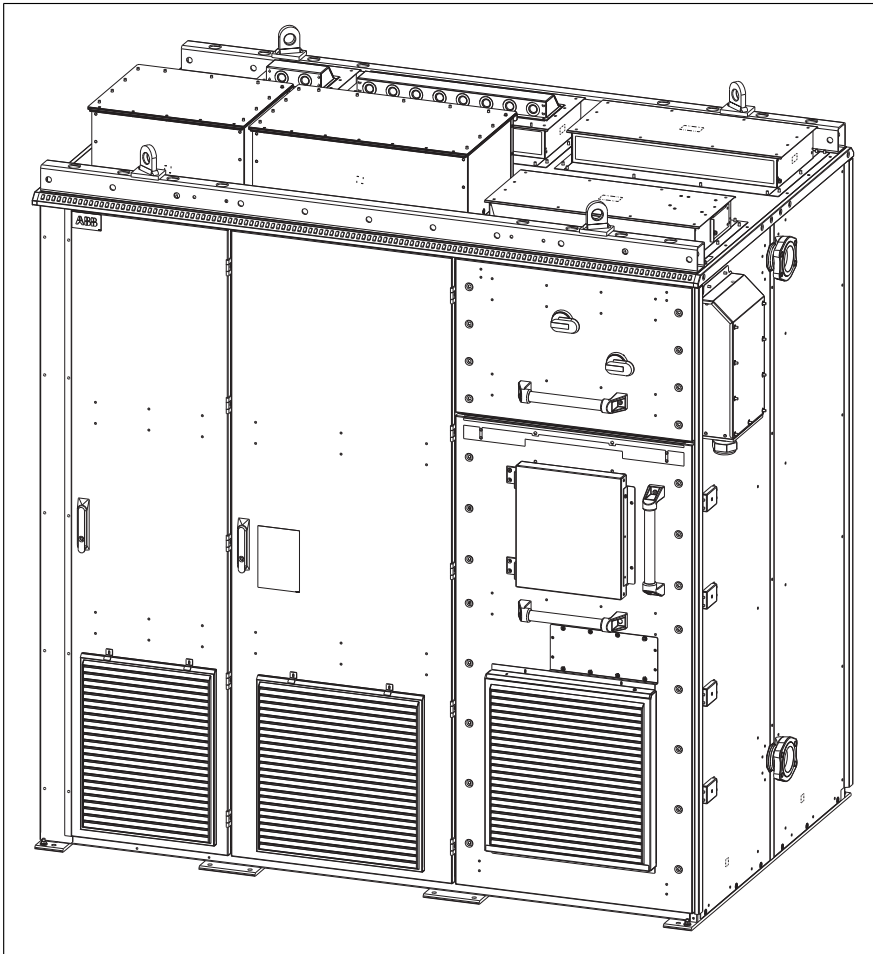

## Generator control

The generator power flows through the generator-side converter to the converter intermediate DC circuit.

The generator control is based on the Direct torque control (DTC) method. Two phase currents and intermediate DC circuit voltage are measured and used for the control. The third phase current is measured for ground fault protection.

---





■ Parallel converters

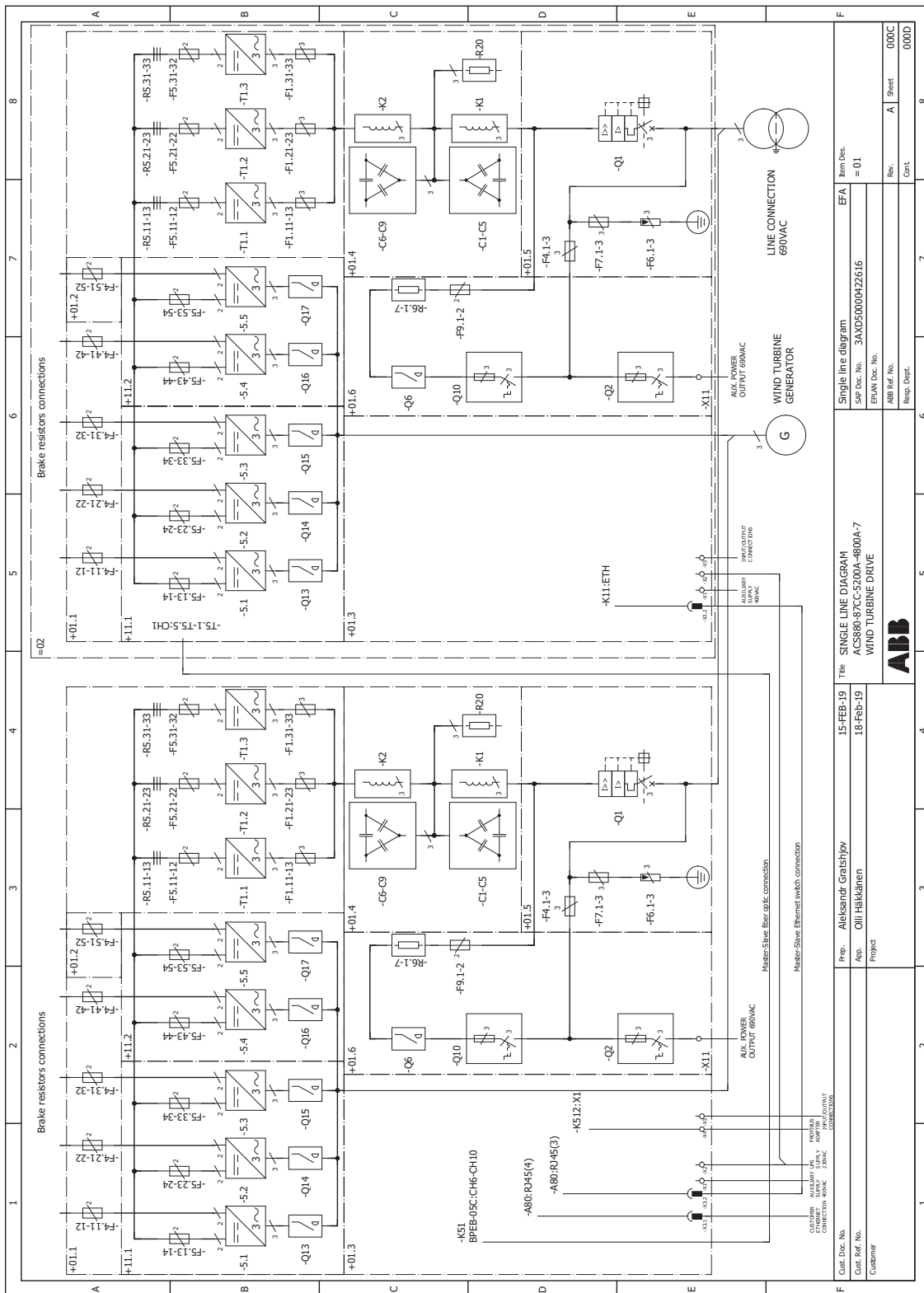

Case Doc. No.	Proj. Aleksandr Grabshov	15-FEB-19	Item Des.	EFA	Item Des.	01
Case Ref. No.	App. Olli Hakkänen	18-FEB-19	SAP Doc. No.	3AXD500092616	Rev.	000C
Customer	Project		EPAM Doc. No.		Cont.	000D
			ABB Ref. No.			
			Respo. Dept.			



**SINGLE LINE DIAGRAM**  
**ACS880-57C5-200A-800A-7**  
**WIND TURBINE DRIVE**

Single line diagram  
 Item Des.  
 = 01

Rev. A Sheet 000C  
 Cont. 000D

## Layout drawing

Layout of the wind turbine converter is shown below.

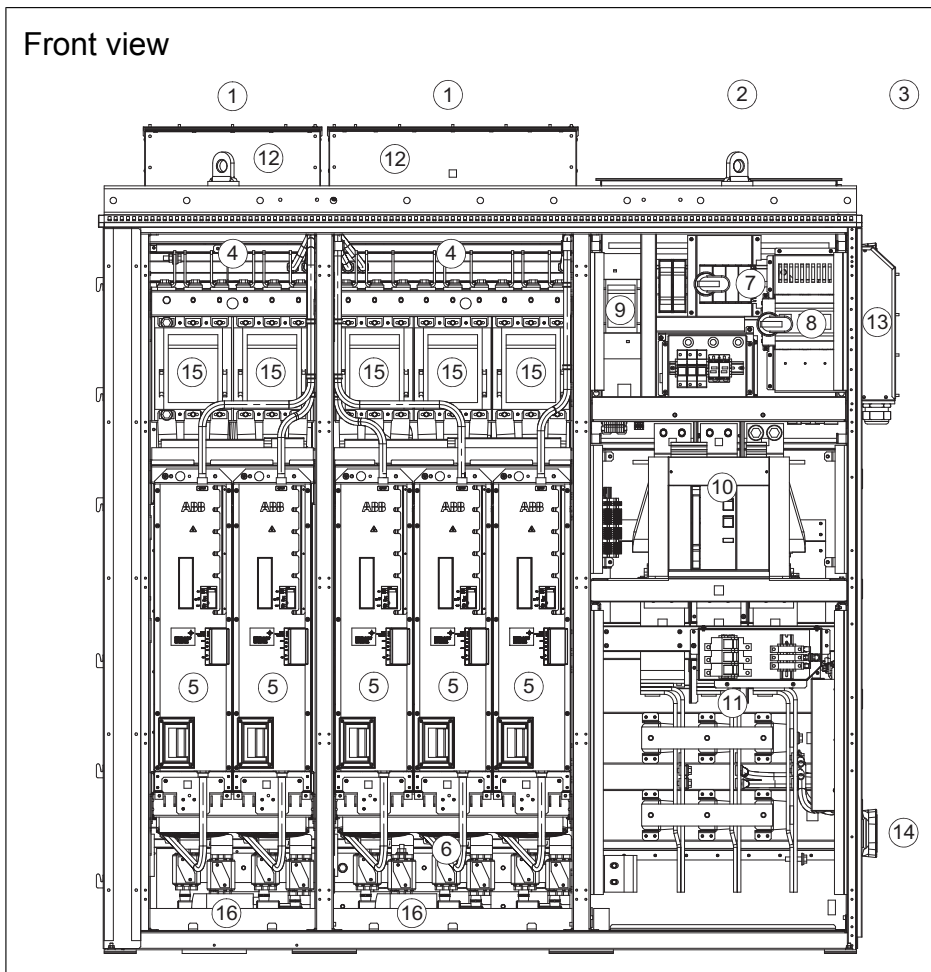

No.	Description
1	Generator-side converter cubicle
2	Main breaker cubicle
3	Space for cooling unit
4	Generator cable terminals [U2, V2, W2]
5	Generator-side converter modules
6	DC fuses
7	Charging circuit switch [Q10]
8	Auxiliary voltage switch [Q2]
9	Charging contactor [Q6]
10	Main circuit breaker [Q1]
11	Grid terminals [L1, L2, L3]
12	Generator cable lead-throughs
13	Auxiliary power output [X11]
14	Coolant connection of the cooling unit (inlet pipe)
15	Output contactors (optional)
16	Optional heaters for cold environment (heating is started at ambient temperature < -20 °C [68 °F])

### 32 Operation principle and hardware description

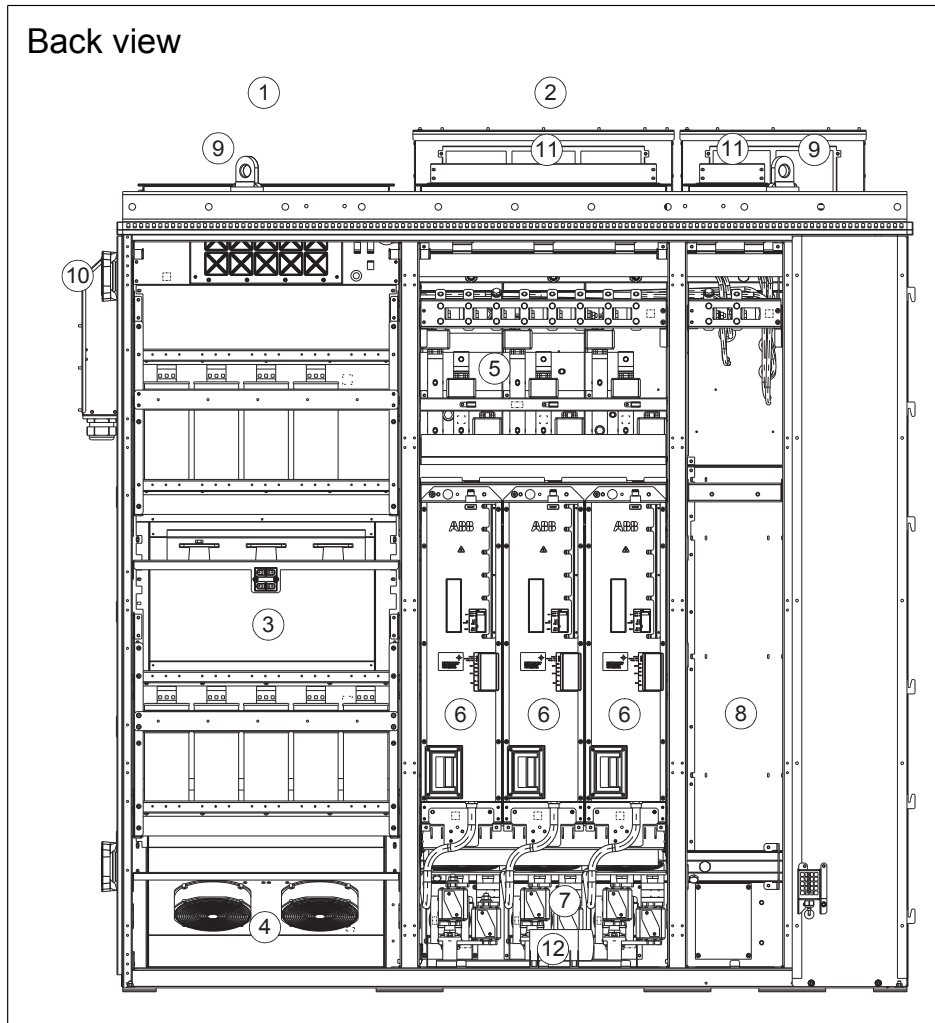

No.	Description
1	LCL filter cubicle
2	Grid-side converter cubicle
3	LCL filter components (inductors are behind the capacitors)
4	Cooling fans of the LCL filter cubicle
5	Grid-side converter AC fuses
6	Grid-side converter modules
7	Grid-side converter DC fuses
8	Space reservation for an additional grid-side converter module
9	Lifting lugs
10	Coolant connection of the cooling unit (outlet pipe)
11	DC resistor cable lead-throughs
12	Optional heaters for cold environment (heating is started at ambient temperature < -20 °C [68 °F])

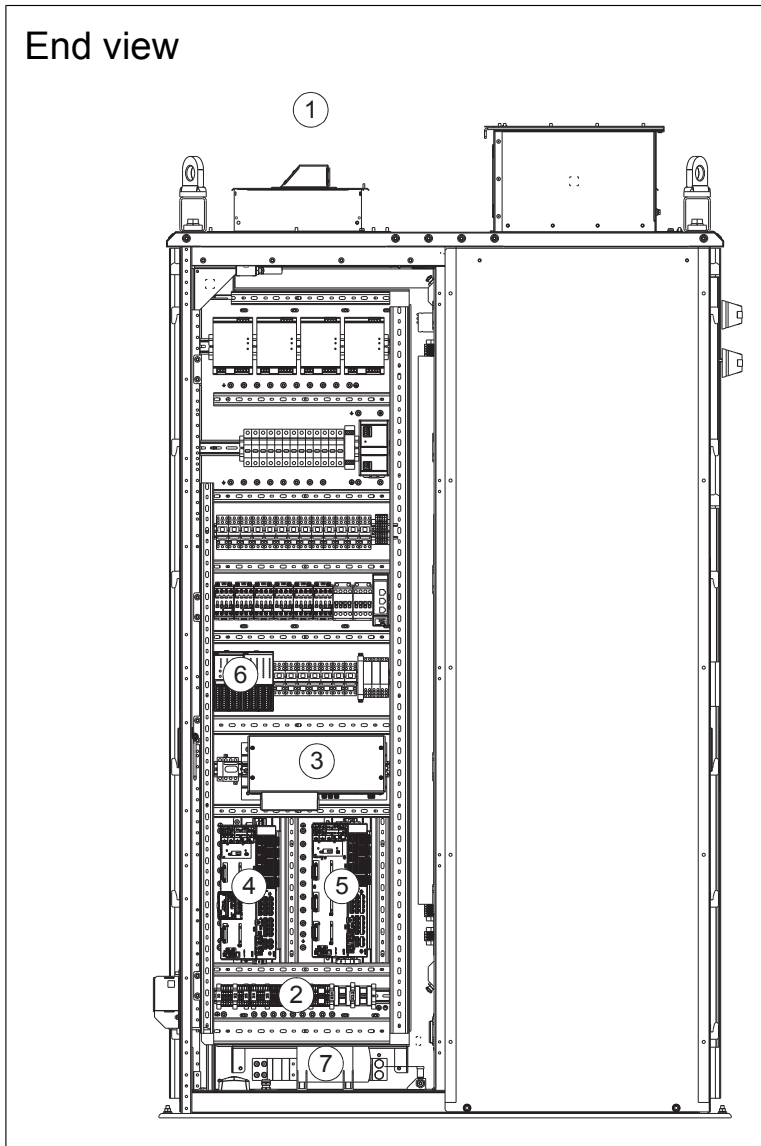

No.	Description
1	Auxiliary control cubicle
2	Control cable terminals for customer connections
3	BAMU measuring unit
4	BCU-22 control unit
5	BCU-15 control unit
6	S500 I/O modules
7	Heater of the auxiliary control cubicle

## Overview of power and control connections

The diagram shows the power connections and internal control interfaces of the wind turbine converter. See also section [Circuit boards \(page 36\)](#). The option module slots on the control unit are reserved for internal use and communication.

### ■ Single converter

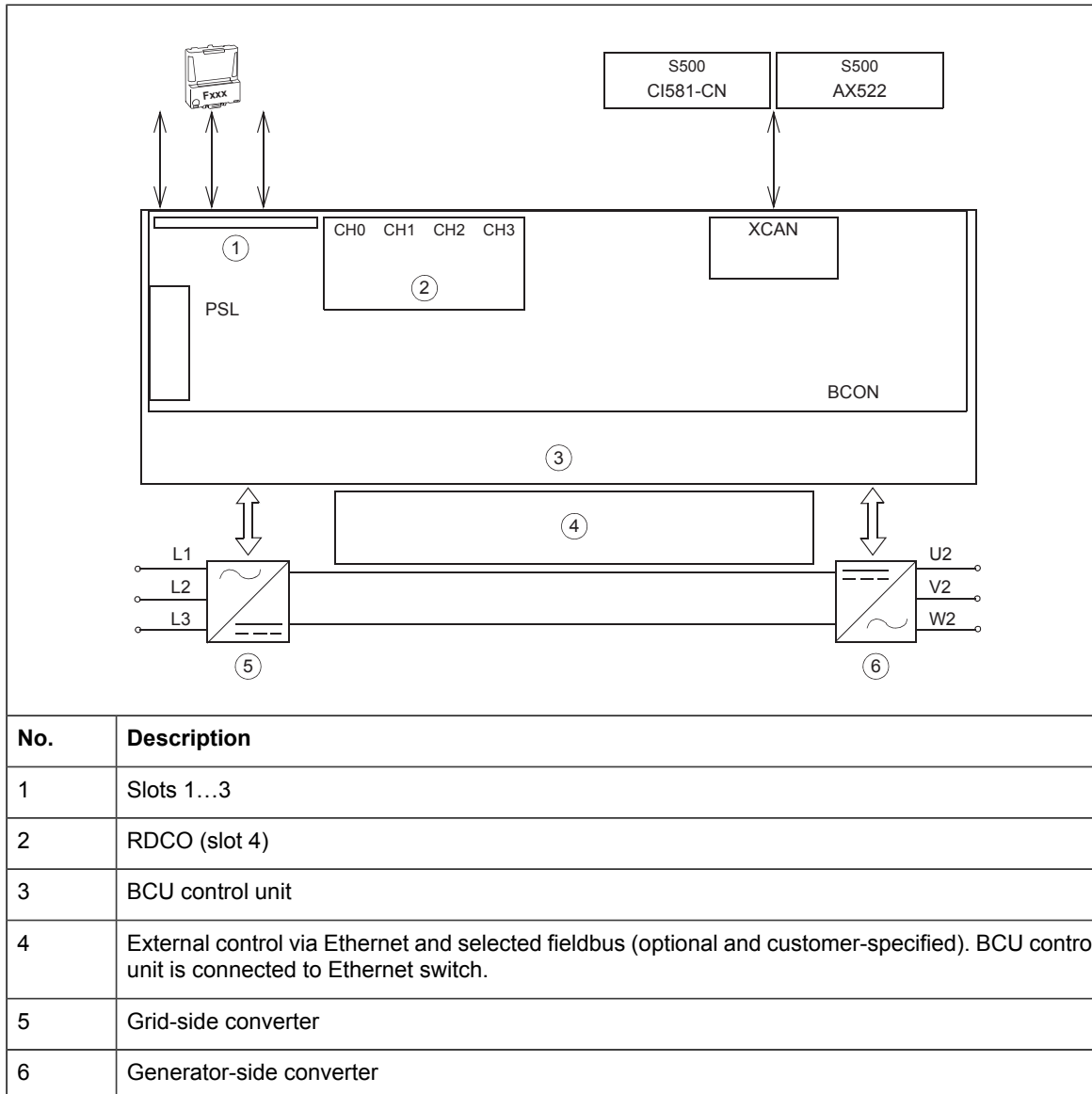

■ Parallel converters

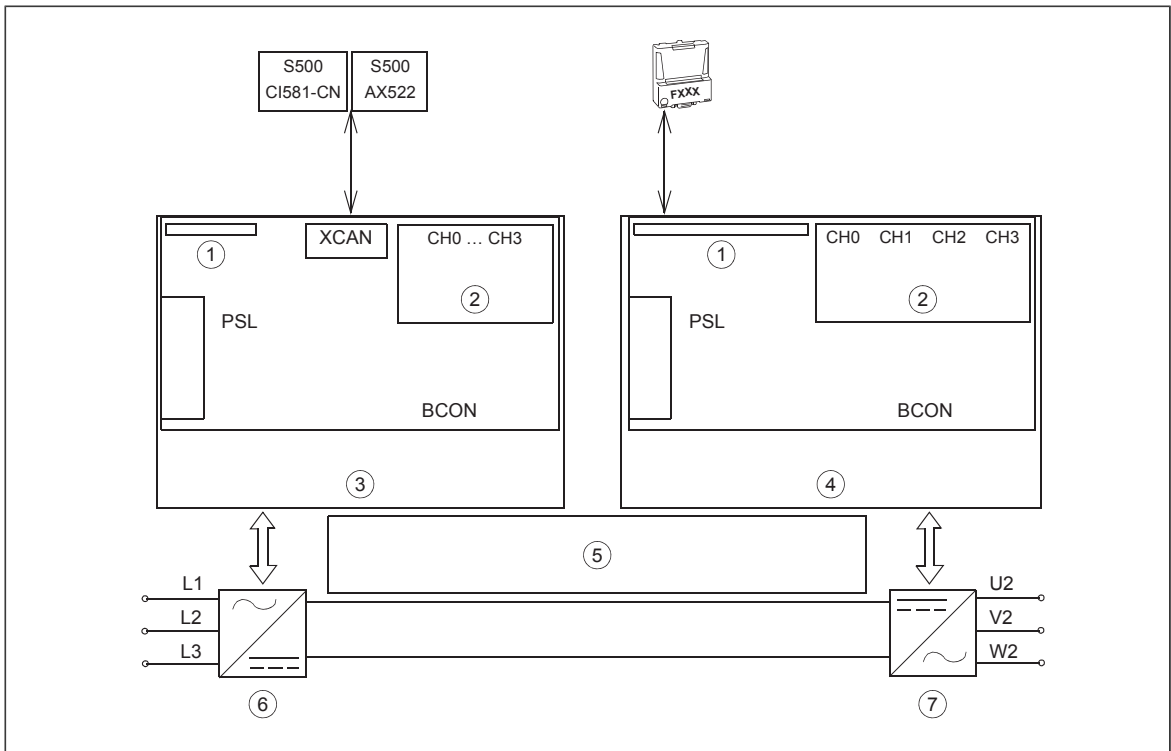

No.	Description
1	Slots 1...3
2	RDCO (slot 4)
3	BCU-x5 control unit
4	BCU-x2 control unit
5	External control via Ethernet and selected fieldbus (optional and customer-specified). Both BCU control units are connected to Ethernet switch.
6	Grid-side converter
7	Generator-side converter





■ Parallel converters

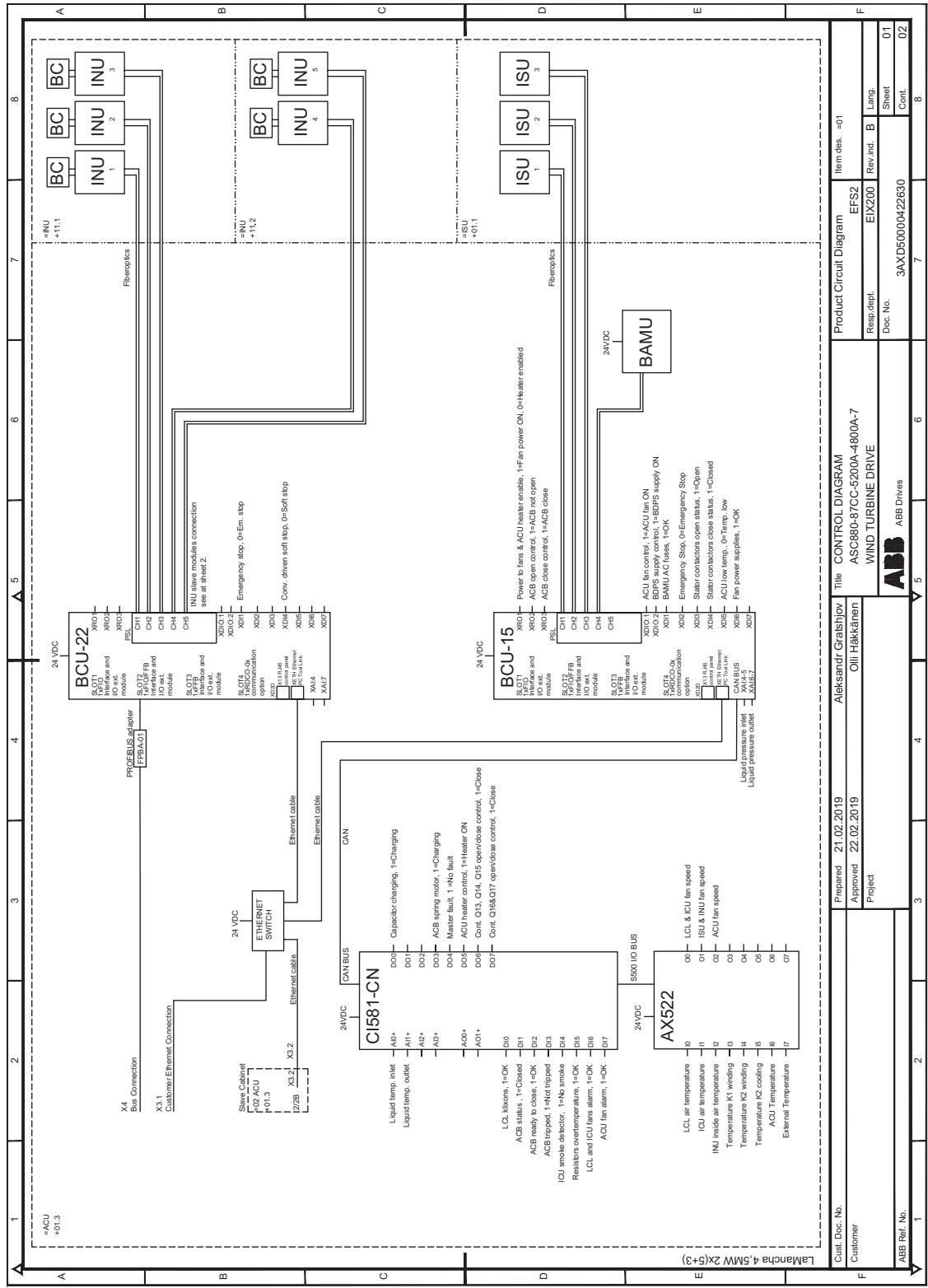

Case No.	21.02.2019	Prepared	Aleksandr Grashjov	Item des.	=01
Customer	22.02.2019	Approved	Olli Häkkinen	Product Circuit Diagram	EFS2
ABB Ref. No.		Project		Responsible	EIX200
				Doc. No.	3AAXD5000422630
				Rev. no.	B
				Lang.	01
				Sheet	01
				Cont.	02

We reserve all rights in this document and in the information contained therein. Reproduction, use or disclosure to third parties without express authority is strictly forbidden. Copr. ABB Automation



## BAMU board

The BAMU board is a multipurpose measurement unit for voltage and current measurement. It has two three-phase voltage inputs and three current inputs.

When the option +F276 (grid fault ride-through) is selected, the BAMU board is included in the delivery for measuring three grid voltages.

## Type designation labels

The type designation label of the wind turbine converter is attached inside the cabinet door. The type designation label includes ratings, valid markings, type code and serial number of the converter. Each converter module is also individually labeled.

Typical labels are shown below.

### ■ Single converter

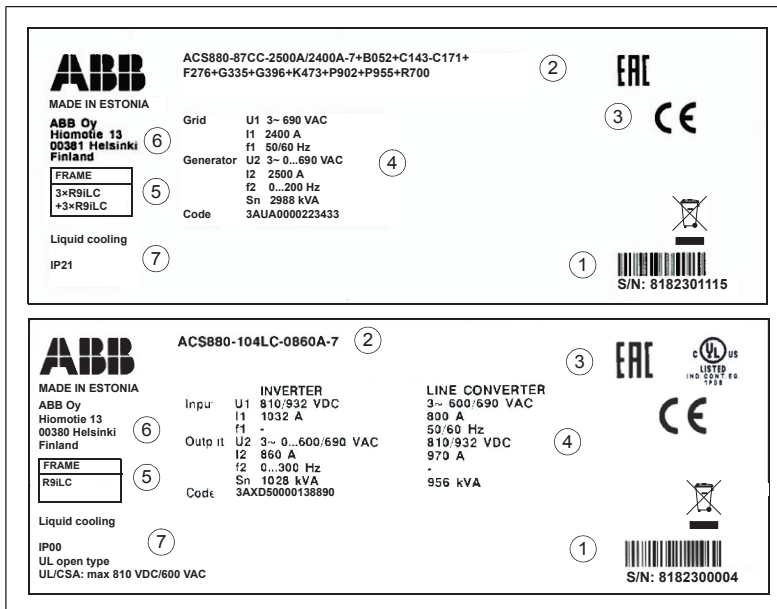

■ Parallel converters

Sales order 1608913/0010 **ABB Oy**  
MADE IN ESTONIA

⑥

Code 3AUA5000079263 ① Serial \*8191000409\*

ACS880-87CC-5200A/4800A-7+K454+C144+C149+H370+H373+H358+D150+F2  
70+C340+R700+F233+Q851+P902+P904

②

**ABB** MASTER DRIVE ACS880-87CC-5200A/4800A-7 ② **CE**  
**ERC** ③

MADE IN ESTONIA

ABB Oy ⑥ Grid U1 3~ 690 VAC  
Hiomote 13 I1 2400 A  
00380 Helsinki f1 50/60 Hz  
Finland Generator U2 3~ 0...690 VAC ④  
FRAME I2 2600 A  
2x(5xR9iLC) ⑤ f2 0...200 Hz  
+2x(3xR9iLC) Code Sn 2988 kVA  
3AUA5000080010

Liquid cooling  
IP21 ⑦ ① S/N: 8191000385





**ABB** SLAVE DRIVE ACS880-87CC-5200A/4800A-7 ② **CE**  
**ERC** ③

MADE IN ESTONIA

ABB Oy ⑥ Grid U1 3~ 690 VAC  
Hiomote 13 I1 2400 A  
00380 Helsinki f1 50/60 Hz  
Finland Generator U2 3~ 0...690 VAC ④  
FRAME I2 2600 A  
2x(5xR9iLC) ⑤ f2 0...200 Hz  
+2x(3xR9iLC) Code Sn 2988 kVA  
3AUA5000080029

Liquid cooling  
IP21 ⑦ ① S/N: 8191102016

No.	Description
1	Serial number. The first digit of the serial number refers to the manufacturing plant. The next four digits refer to the converter's manufacturing year and week, respectively. The remaining digits complete the serial number so that there are no two converters with the same number.
2	Type code. See section <a href="#">Type designation key (page 41)</a> . If the delivery contains a DC chopper, option code +D150 is marked in the converter label.

No.	Description
3	<p>Valid markings. Possible markings are, for example:</p> <ul style="list-style-type: none"> <li>•CE marking  </li> <li>•EAC marking  </li> <li>•UL marking  </li> <li>•RCM marking  </li> <li>•WEEE marking  </li> </ul> <p>See the technical data.</p>
4	Ratings of the converter
5	<p>Number and frame size of the converter modules.</p> <p>In the upper label for the ACS880-87CC converter, there are five generator-side converter modules, three grid-side converter modules, and the frame size is R9iLC.</p> <p>In the lower label for converter module, the frame size of the module is R9iLC.</p>
6	Manufacturing location
7	Information about cooling, IP class etc.

## Type designation key

The type code of the wind turbine converter contains information on the specifications and configuration.

- The first 23 digits form the basic code. It describes the basic construction of the wind turbine converter. The fields in the basic code are separated with hyphens.
- The option codes follow the basic code. Each option code starts with an identifying letter (common for the whole product series), followed by descriptive digits. The option codes are separated by plus signs.

The selections are listed below. For more information, contact your local ABB representative.

## ■ Basic code

Digit no.	Name/Description	Alternatives	Description
1...6	Product series	ACS880	ACS880 product series
8...11	Construction	87CC	Cabinet-installed combined-cooled wind turbine converter
13...23	Size	See the ratings.	Generator-side converter current rating / Grid-side converter current rating
25	Voltage rating	7	7 – Voltage range 525...690 V. This is indicated in the type designation label as a typical input voltage level (3~ 690 V AC).

## ■ Option codes (plus codes)

Code	Description
<b>Degree of protection</b>	
B052	IP21 (UL type 1)
<b>Construction</b>	
C129	UL approved components
C143	Cooling connections on the right side
C144	Cooling connections on the left side
C171	Flange for cooling liquid connections of size DN64 with flange clamp, ISO 6162-1:2002
<b>Grid control options</b>	
F276	Grid fault ride-through
<b>Cabinet options</b>	
G335	Current transformers for grid current measurement
G396	Auxiliary 3-phase power output - 125 A
<b>Fieldbus</b>	
K453	Interbus-S® adapter module
K454	FPBA-01 PROFIBUS DP adapter module
K455	Modbus Plus® adapter module
K457	FCAN-01 CANopen adapter module
K458	Modbus® adapter module
K473	FENA-11 Ethernet adapter module (EtherNet/IP™, Modbus TCP®, PROFINET)
<b>Ethernet</b>	
K464	NETA-21 remote monitoring tool (EIP, MB/TCP)
K466	Ethernet (Modbus TCP, EtherNet/IP) adapter
K467	Ethernet (Modbus TCP, PROFINET IO®) adapter

<b>Code</b>	<b>Description</b>
<b>I/O options</b>	
L500	FIO-11 analog I/O extension module
L501	FIO-01 digital I/O extension module
L502	FEN-31 HTL incremental encoder interface module
L503	DDCS communication 3
L504	Additional I/O - terminal block
L505	Thermistor relay
L506	Pt100 relay
L507	115 V AC input
L508	DDCS communication 1
L509	DDCS communication 2
<b>Safety</b>	
Q951	Emergency Stop, Category 0
<b>Documentation language (delivered set may include documents in English)</b>	
R700	English
<b>Specialities</b>	
P902	Customized (described in Technical Appendix)
P904	Extended warranty 1
P909	Extended warranty 2
P910	Service plan 1
P911	Service plan 2
P912	Seaworthy packing
P955	Customer specific warranty 60/72
3AXD10000050824	





# 4

## Mechanical installation

---

### Contents of this chapter

This chapter describes the mechanical installation procedure of the wind turbine converter.

### Safety instructions

See the safety instructions.



## Checklist before mechanical installation

	<input checked="" type="checkbox"/>
<p><b>The installation site</b></p> <p>Check the installation site. See the technical data for the allowed operating conditions and for the requirements for free space around the converter.</p> <p>Check that the floor that the converter is installed on is of non-flammable material, as smooth as possible, and strong enough to support the weight of the converter.</p> <p>Check the floor flatness with a spirit level. The maximum allowed deviation from the surface level is 5 mm (0.2 in) in every 3 meters (9.8 ft).</p> <p>If necessary, level the installation site, as the cabinet is not equipped with adjustable feet.</p> <p>Check that the wall behind the converter is of non-flammable material.</p>	<input type="checkbox"/>
<p><b>Required tools</b></p> <p>Check that you have following tools for moving the converter to its final position, fastening it to the floor and tightening the connections:</p> <ul style="list-style-type: none"> <li>•crane or fork-lift (check the load capacity); iron bar and piece of planked wood</li> <li>•Pozidriv and Torx (2.5 ... 6 mm, 0.98 ... 0.2 in) screwdrivers for the tightening of the frame screws (Screws needed for fastening the cabling boxes and other accessories delivered by ABB are included in the delivery. They are inside the cabinet. The delivery does not contain screws or tools to install the cabinet to the floor.)</li> <li>•torque wrench</li> <li>•set of wrenches and sockets.</li> </ul>	<input type="checkbox"/>
<p><b>The delivery</b></p> <p>For unpacking the delivery, see page 48.</p> <p>Check that the delivery contains:</p> <ul style="list-style-type: none"> <li>•converter cabinet (<u>parallel converters</u>: both converter cabinets of the same delivery)</li> <li>•cabling boxes for the generator-side converter</li> <li>•option modules (installed at the factory)</li> <li>•DC chopper(s) and DC resistor(s) (optional)</li> <li>•filters of the door air inlets</li> <li>•appropriate wind turbine converter manual(s) and option module manual(s)</li> <li>•delivery documents (dimension drawings, circuit diagrams, etc.)</li> </ul> <p>The manual(s) are delivered inside the converter.</p> <p>Check that there are no signs of damage.</p> <p>Check the information on the type designation label of the converter to verify that the delivery is of correct type.</p>	<input type="checkbox"/>



## Moving the converter package

### ■ Moving the converter package by fork-lift



#### **WARNING!**

Only use a heavy duty forklift that can carry the weight of the converter.

- Make sure that the reach of the fork lift is long enough. The package is wide and the center of gravity is far from the edges.
- Do not tilt. The center of gravity is high.
- Move only in the upright position.

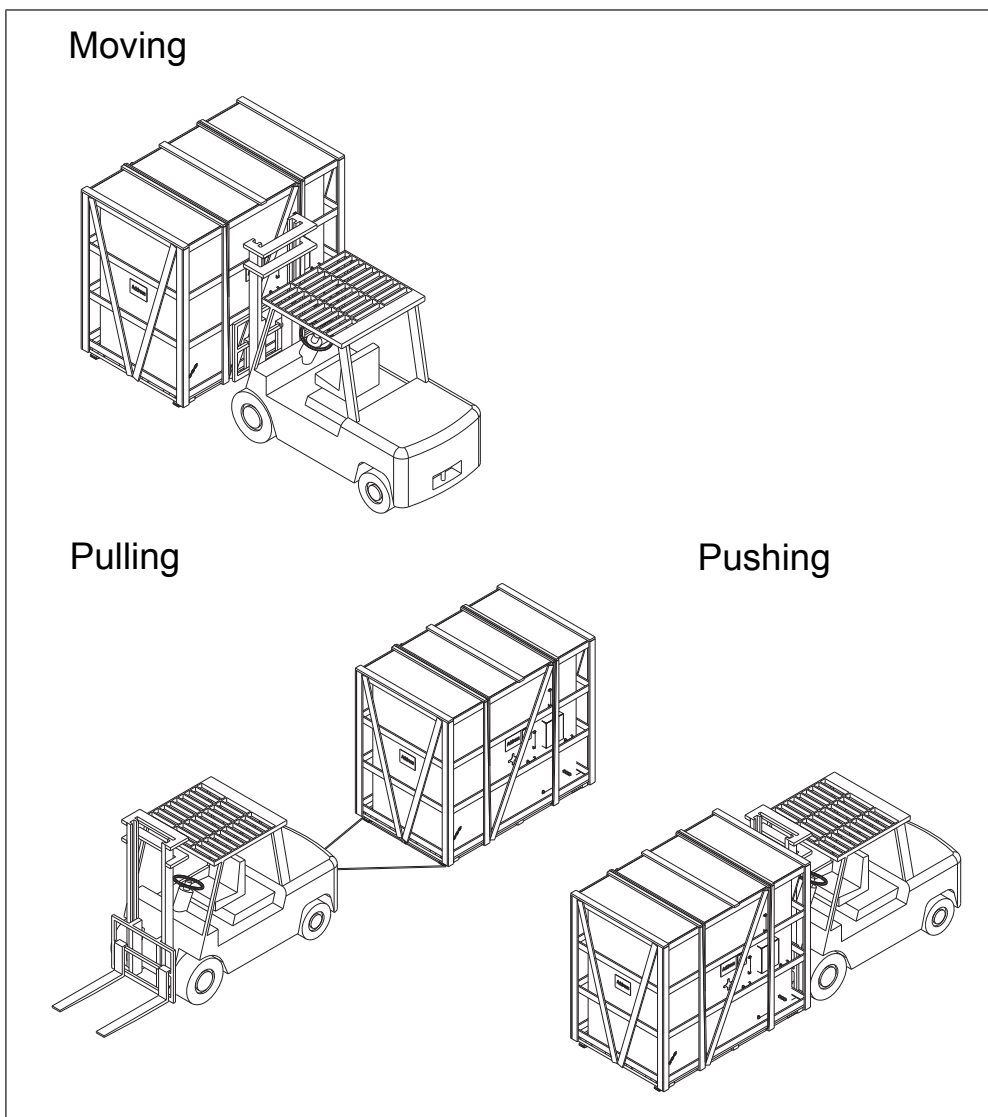

### ■ Moving the converter on rollers

Do not move the converter on rollers.

## Unpacking

Unpack the wind turbine converter when you have moved the converter to its final installation location, or near it.

1. Cut the attachment clamps with side cutters and pull them away.
2. Remove the fastening screws/nails/rivets and unpack the converter from the wooden package.
3. Cut the plastic covering the converter with a carpet knife and remove it.
4. Detach the converter from its platform, lift the converter and remove the platform.

## Lifting the converter

Obey these instructions when there are no ABB lift adapter bars in use:

1. Attach the lifting slings to holes of the lifting bars (a). Use long enough slings. See the minimum lifting angle in the figure below.



**WARNING!**

Divide the weight to all lifting bars and all holes. If you do not divide the load evenly, the lifting bars can not carry the weight of the converter.

---

2. Tighten the slings steadily and make sure that the load is evenly divided.
3. Lift steadily.
4. Position the converter as near its final position as possible.
5. If the lifting bars are removed, refasten the roof bolts to retain the degree of protection of the cabinet.



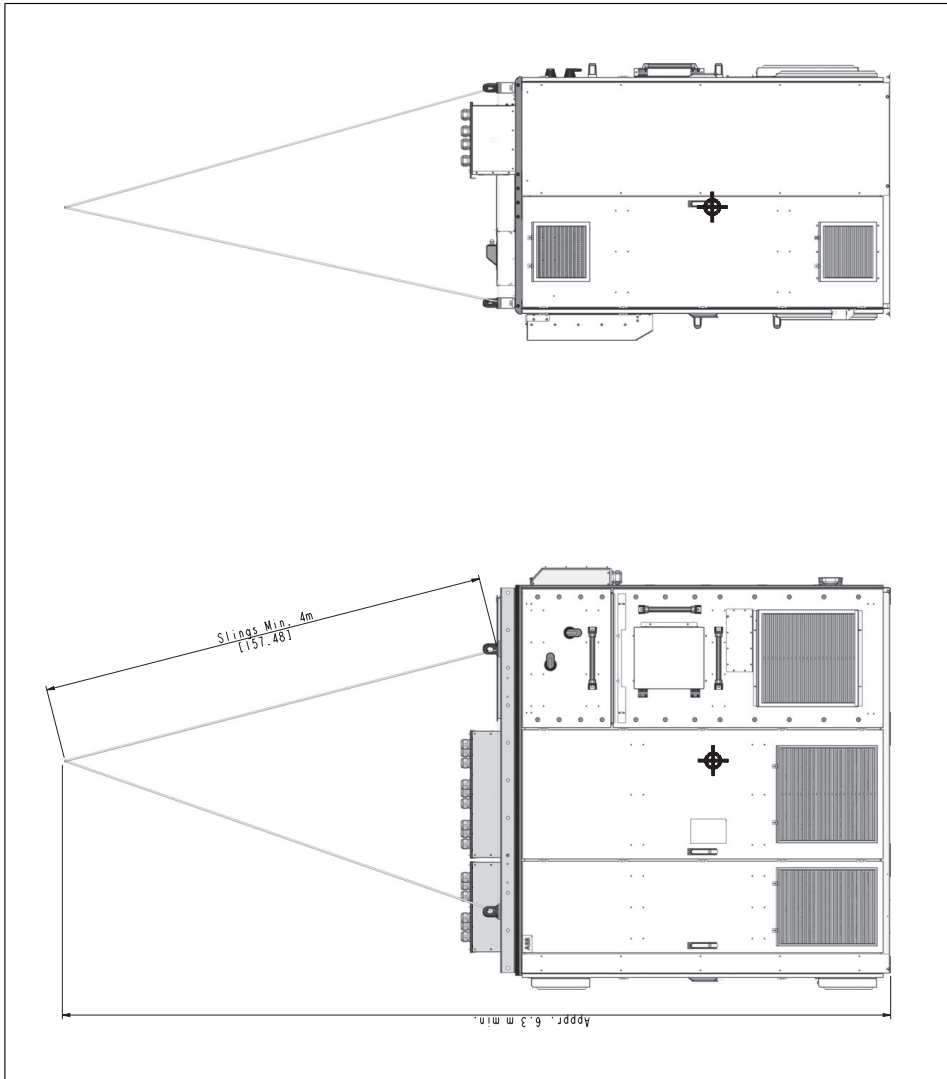

## Placing the converter

The cabinet can be placed into its final position with an iron bar and a wooden piece at the bottom edge of the cabinet. Place the wooden piece carefully to avoid damage to the cabinet frame.

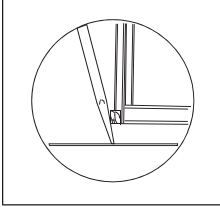

The cabinet has a back-to-back design, and thus you cannot install it with a longer side against a wall.

The converter must be installed in an upright vertical position.

### Notes:

- Leave a 400 mm (16 in) clearance above the converter cabinet.
- Leave space at the side for the coolant pipes.
- You can adjust the height, for example, if the floor is uneven by using metal shims between the cabinet frame and floor.

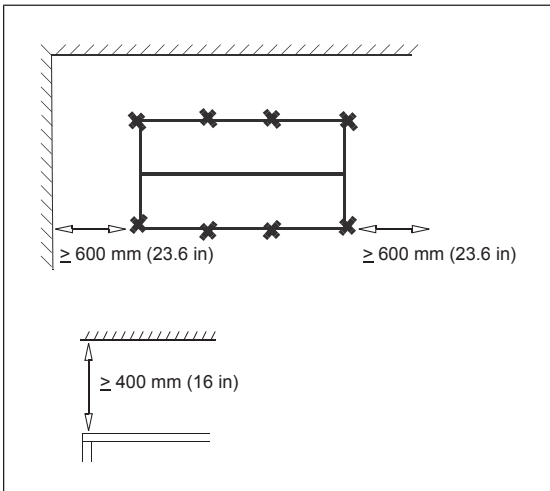

## Fastening the cabinet to the floor

Bolt the converter to the floor through the holes in each flat bar at the base of the cabinet using M12 screws.

We do not recommend welding (see section [Electric welding \(page 51\)](#)).

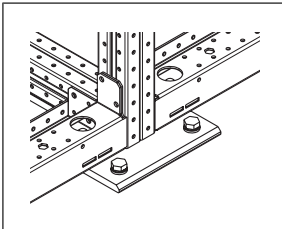

## Internal cooling circuit

For installations related to cooling, see the mechanical installation instructions in chapter [Cooling and heating](#).

## Lifting the door

1. Unlock the door with the triangle key delivered with the cabinet. Open the handles.
2. Detach the upper part of the door.
3. Lift the door upwards.

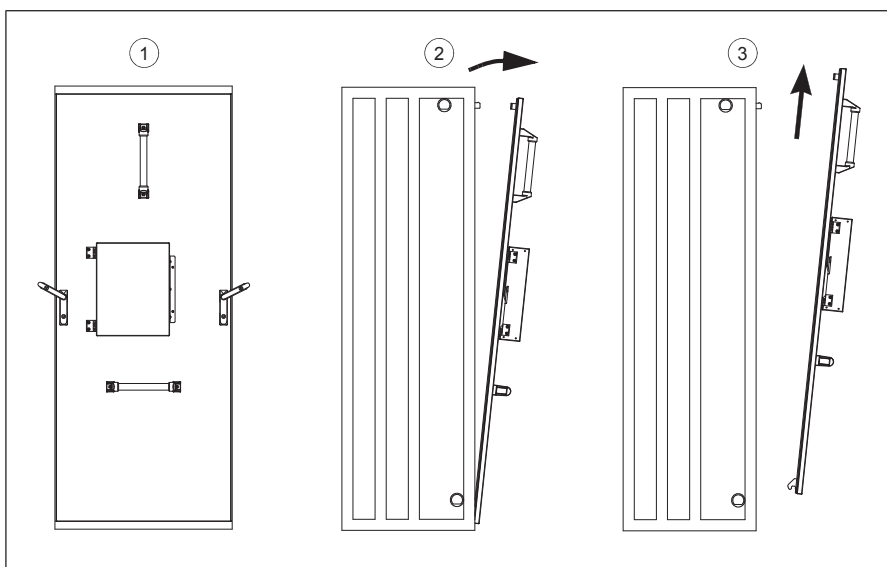

## Miscellaneous

### ■ Cable duct in the floor below the cabinet

Prevent the cooling air flow from the cable duct to the cabinet by bottom plates. To ensure the degree of protection for the cabinet use the original bottom plates delivered with the converter. With user-defined cable entries, take care of the degree of protection, fire protection and EMC compliance.

### ■ Electric welding

It is not recommended to fasten the cabinet by welding. If you must do it for some reason:

- Weld only the flat bar under the cabinet, never the cabinet frame itself.
- Clamp the welding electrode onto the flat bar about to be welded or to the next flat bar of the cabinet (within 0.5 meters (1'6") of the welding point).



**WARNING!**

If the welding return wire is connected improperly, the welding circuit may damage electronic circuits in the cabinet. The thickness of the zinc coating of the cabinet frame is 100...200 micrometers; on the flat bars the coating is approximately 20 micrometers. Ensure that the welding fumes are not inhaled.

---





# 5

## Planning the electrical installation

---

### Contents of this chapter

This chapter contains the instructions that you must follow when selecting the generator, cables, protections, cable routing and way of operation for the converter system.

**Note:** The installation must always be designed and made according to applicable local laws and regulations. ABB does not assume any liability whatsoever for any installation which breaches the local laws and/or other regulations. Furthermore, if the recommendations given by ABB are not followed, the converter may experience problems that the warranty does not cover.

### Selecting the grid disconnecting device

The converter is equipped with a main circuit breaker as standard. However, the opened main circuit breaker does not isolate the grid cable terminals of the converter from the grid. Equip the installation with another disconnecting device placed in between the power grid and the grid cable terminals of the converter. For example, the main circuit breaker of the grid transformer could also be used as the extra disconnecting device if it meets the requirements for a disconnecting device.

---

## Checking the compatibility of the generator and the converter

The converter is compatible with induction generators and permanent magnet generators.

1. Select the generator according to the ratings table in the technical data.
2. Check that the generator and the converter have the same voltage rating. Check also that the voltage ratings match the voltage to be connected to the grid-side converter.

**Note:** You can rise the converter DC link voltage 10% of its natural level (by a parameter setting). The effect is equivalent to a 10% voltage rise at the generator terminals. Before you use this feature, make sure that the generator insulation can withstand the higher voltage level.

When	the generator voltage rating should be
DC bus voltage is not increased from nominal (default)	$U_N$
DC bus voltage is increased from nominal by parameter setting	$U_{ACeq}$
$U_N$ = rated grid-side voltage of the converter $U_{ACeq}$ = equivalent grid-side voltage of the converter in V AC, $U_{ACeq} = U_{DC} / 1.41$ $U_{DC}$ = maximum DC bus voltage of the converter in V DC. You can set the voltage reference with parameter in grid-side converter control program for $1.1 \cdot 1.41 \cdot U_N$ at maximum. You can set the reference to a lower value but the program restricts it to a value of at least $1.41 \cdot U_N$ .	

3. Make sure that the generator is suitable for the converter use, ie, it can withstand the voltage peaks at of the converter:
  - Use insulated N end (non-driven end) bearing in the generator.
  - Make sure that the generator insulation meets the requirements in the table below.
  - Select the cables according to the instruction in this manual.
  - Install the converter and its cabling as instructed in this manual.

### ■ Protecting the generator insulation and bearings

The generator-side converter output of the wind turbine converter comprises – regardless of output frequency – pulses of approximately the converter DC bus voltage with a very short rise time. This is the case with all converters employing modern IGBT technology.

The voltage of the pulses can be almost double at the generator terminals, depending on the attenuation and reflection properties of the generator cable and the terminals. This in turn can cause additional stress on the generator and generator cable insulation.

Modern variable speed converters with their fast rising voltage pulses and high switching frequencies can cause current pulses that flow through the generator bearings, which can gradually erode the bearing races and rolling elements.

ABB power modules are equipped with internal du/dt filters which reduce the bearing currents and stress on the generator insulations. In addition, a common mode filter can be used to reduce such stresses on the generator-side. Hence, the converter can be equipped with following filters:

- du/dt filter protects generator insulation system and reduces bearing currents
- common mode filter mainly reduces bearing currents (option).

To avoid damage to generator bearings, the cables must be selected and installed according to the instructions given in this manual. In addition, insulated N-end (non-converter end) bearings must be used.

## Selecting the power cables

### ■ General rules

Dimension the grid cable or busbar and generator cable **according to local regulations**:

- The cable must be able to carry the converter load current. See the technical data for the rated currents.
- The cable must be rated for at least 90 °C (194 °F) maximum permissible temperature of conductor in continuous use. See also section *Additional US and Canada requirements (page 59)*.
- The inductance and impedance of the PE conductor/cable (grounding wire) must be rated according to permissible touch voltage appearing under fault conditions (so that the fault point voltage will not rise excessively when a ground fault occurs).
- The rated voltage between the conductors of the cable should be minimum 1 kV.

For generators, the symmetrical shielded generator cable is highly recommended. See section *Alternative power cable types (page 57)*.

**Note:** When continuous conduit is employed, shielded cable is not required.

**Note:** When using a four-conductor system, consult the generator manufacturer regarding bearing and disturbance shielding.

In a non-symmetrical four-conductor system, voltage can be induced to the separate PE conductor, which rises generator frame potential and causes current to ground through the generator bearings and shaft. This causes extra wear. Whereas, in a symmetrical shielded cable, the high capacitance between the PE conductor and the phase conductors forms an LC filter reducing bearing currents and voltage changes.

A four-conductor system is allowed for grid cabling, but shielded symmetrical cable is highly recommended.

### ■ Sufficient conductivity of the protective conductor

The protective conductor must always have an adequate conductivity.

Unless local wiring regulations state otherwise, the cross-sectional area of the protective conductor must agree with the conditions that require automatic disconnection of the supply required in 411.3.2. of IEC 60364-4-41:2005 and be capable of withstanding the prospective fault current during the disconnection time of the protective device.

The cross-sectional area of the protective conductor can either be selected from the table below or calculated according to 543.1 of IEC 60364-5-54.

This table shows the minimum cross-sectional area related to the phase conductor size according to IEC 61800-5-1 when the phase conductor and the protective conductor are made of the same metal. If this is not so, the cross-sectional area of the protective earthing

conductor shall be determined in a manner which produces a conductance equivalent to that which results from the application of this table.

Cross-sectional area of the phase conductors S (mm <sup>2</sup> )	Minimum cross-sectional area of the corresponding protective conductor S <sub>p</sub> (mm <sup>2</sup> )
S ≤ 16	S
16 < S ≤ 35	16
35 < S ≤ 400	S/2
400 < S ≤ 800	200
800 < S	S/4

Compared to a four-conductor system, the use of symmetrical shielded cable reduces electromagnetic emission of the whole converter system as well as generator bearing currents and wear.

The generator cable and its PE pigtail (twisted screen) should be kept as short as possible in order to reduce electromagnetic emission as well as capacitive current.

### ■ Typical power cable sizes

#### CE cables

Generator cables					
Converter type ACS880-87CC-	Cable type	Conductor type	Total quantity of parallel conductors per phase		
			300 mm <sup>2</sup>	240 mm <sup>2</sup>	185 mm <sup>2</sup>
5200A/4800A-7	EPR	Copper	2×6	2×7	2×8
5160A/4800A-7	EPR	Copper	2×6	2×7	2×8
6880A/5500A-7	EPR	Copper	2×8	2×9	2×10

Grid cables					
Converter type ACS880-87CC-	Cable type	Conductor type	Total quantity of parallel conductors per phase		
			300 mm <sup>2</sup>	240 mm <sup>2</sup>	185 mm <sup>2</sup>
5200A/4800A-7	EPR	Copper	2×5	2×6	2×7
5160A/4800A-7	EPR	Copper	2×5	2×6	2×7
6880A/5500A-7	EPR	Copper	2×6	2×7	2×8

DC resistor cables			
Converter type ACS880-87CC-	Cable type	Conductor type	Number of conductor pairs per DC chopper module
			35 mm <sup>2</sup>
5200A/4800A-7	EPR	Copper	2×1
5160A/4800A-7	EPR	Copper	2×1
6880A/5500A-7	EPR	Copper	2×1

## UL cables

Generator cables						
Converter type ACS880-87CC-	Cable type	Conductor type	Total quantity of parallel conductors per phase			
			1000 kcmil	500 kcmil	400 kcmil	350 kcmil
5200A/4800A-7	EPR	Copper	2×10	2×14	2×15	2×17
5160A/4800A-7	EPR	Copper	2×10	2×14	2×15	2×17
6880A/5500A-7	EPR	Copper	2×13	2×18	2×20	2×22

Grid cables						
Converter type ACS880-87CC-	Cable type	Conductor type	Total quantity of parallel conductors per phase			
			1000 kcmil	500 kcmil	400 kcmil	350 kcmil
5200A/4800A-7	EPR	Copper	2×9	2×13	2×14	2×15
5160A/4800A-7	EPR	Copper	2×9	2×13	2×14	2×15
6880A/5500A-7	EPR	Copper	2×10	2×14	2×16	2×18

DC resistor cables			
Converter type ACS880-87CC-	Cable type	Conductor type	Number of conductor pairs per DC chopper module
			70 kcmil
5200A/4800A-7	EPR	Copper	2×1
5160A/4800A-7	EPR	Copper	2×1
6880A/5500A-7	EPR	Copper	2×1

### ■ Alternative power cable types



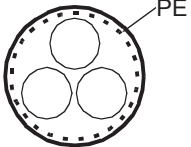
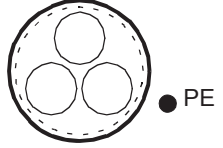
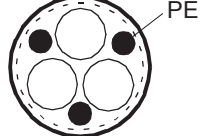

The power cable types that you can use with the converter are shown below.

	<p>Symmetrical shielded cable with three phase conductors and a concentric PE conductor as shield. The shield must meet the requirements of IEC 61800-5-1. Check with local / state / country electrical codes for allowance.</p>
	<p>Symmetrical shielded cable with three phase conductors and a concentric PE conductor as shield. A separate PE conductor is required if the shield does not meet the requirements of IEC 61800-5-1.</p>
	<p>Symmetrical shielded cable with three phase conductors and symmetrically constructed PE conductor, and a shield. The PE conductor must meet the requirements of IEC 61800-5-1.</p>

### Power cable types for limited use

	<p>A four-conductor system (three phase conductors and a protective conductor on a cable tray) is not recommended for cabling.</p>
---	--

**Not allowed power cable types**

	<p>A four-conductor system (three phase conductors and a PE conductor in a PVC conduit)</p>
	<p>Corrugated cable with three phase conductors and a protective conductor or cable in EMT conduit</p>
	<p>A well-shielded (Al/Cu shield) four-conductor system (three phase conductors and a PE conductor or four conductors)</p>
	<p>Symmetrical shielded cable with individual shields for each phase conductor is not allowed on any cable size for grid and generator cabling.</p>

**Generator cable shield**

If the generator cable shield is used as the sole protective earth conductor of the generator, make sure that the conductivity of the shield is sufficient. See subsection *General rules* above, or IEC 61800-5-1.

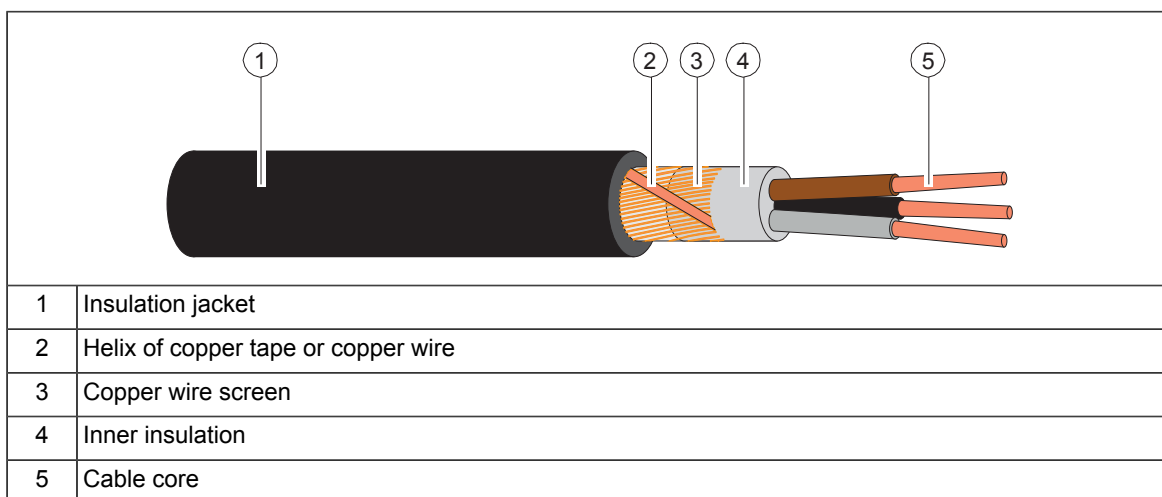

To effectively suppress radiated and conducted radio-frequency emissions, the cable shield conductivity must be at least 1/10 of the phase conductor conductivity. The requirements are easily met with a copper or aluminum shield. The minimum requirement of the generator cable shield of the converter is shown below. It consists of a concentric layer of copper wires with an open helix of copper tape or copper wire. The better and tighter the shield, the lower the emission level and bearing currents.



■ **Single core vs multicore cables in grid cabling**

Use symmetrical grid cabling. Asymmetry leads to unequal current distribution between the conductors which may cause disturbances and fault trips. To avoid asymmetry, use symmetrical multicore (three-phase) cables where possible. Single core cabling is also allowed if the cables are grouped symmetrically.

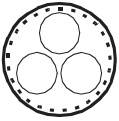
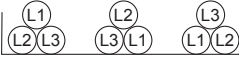
The table below shows three possible cabling options.

No.	Layout	Description
1		Multicore cabling (recommended). See subsection <i>Alternative power cable types</i> for the possible constructions of the PE (protective earth/ground).
2		Single core cables in trefoil (preferable single core cabling option).
3		Single core cables laid flat.

■ **Additional US and Canada requirements**

Use copper, copper-clad aluminum or aluminum conductors. Use conductors rated for 90 °C (194 °F) only.

Run the cabling in metallic conduits, or use type MC continuous corrugated aluminum armor cable with symmetrical grounds or shielded power cable for the generator cables if metallic conduit is not used.

**Conduit**

Bridge the joints of the conduits with a ground conductor bonded to the conduit on each side of the joint. Bond the conduits also to the converter enclosure. Use separate conduits for grid, generator, DC resistors, and control wiring. A dedicated ground cable is always required.

**Note:** Do not run generator wiring from more than one converter in the same conduit.

**Armored cable / shielded power cable**

6-conductor (3 phases and 3 ground) type MC continuous corrugated aluminum armor cable with symmetrical grounds is available from the following suppliers (trade names in parentheses):

- Anixter Wire & Cable (Philsheath)
- BICC General Corp (Philsheath)
- Rockbestos Co. (Gardex)
- Oaknite (CLX).

Shielded power cables are available from Belden, Lapp Kabel (ÖLFLEX) and Pirelli, among others.

## Selecting the control cables

■ **General rules**

All control cables must be shielded.

As a general rule, the control signal cable shield should be grounded directly in the wind turbine converter. The other end of the shield should be left unconnected or grounded indirectly via a high frequency, high voltage capacitor of a few nanofarads. The screen can also be grounded directly at both ends if they are in the same earth line with no significant voltage drop between the end points.

Use a double shielded twisted pair cable (see figure a) for analog signals. This type of cable is recommended for the pulse encoder signals as well. Employ one individually shielded pair for each signal. Do not use common return for different analog signals.

A double shielded cable is the best alternative for low voltage digital signals but single shielded twisted multipair cable (figure b) is also acceptable.

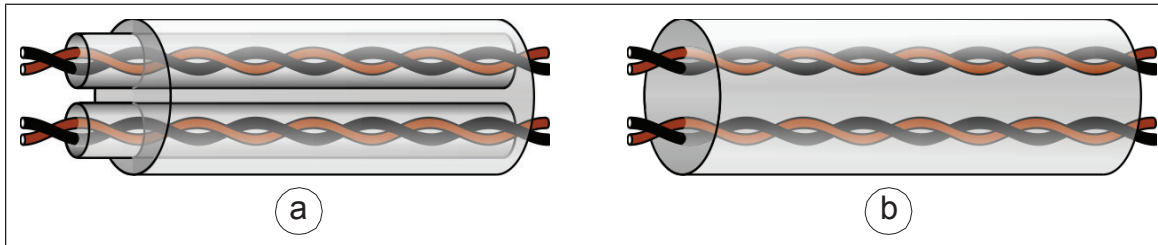

Run analog and digital signals in separate, shielded cables.

Relay-controlled signals, providing their voltage does not exceed 48 V, can be run in the same cables as digital input signals. It is recommended to run the relay-controlled signals as twisted pairs.

Never mix 24 V DC and 115 / 230 V AC signals in the same cable.

#### ■ **Relay cable**

The cable type with braided metallic screen (for example, ÖLFLEX from Lapp Kabel, Germany) has been tested and approved by ABB.



## Routing the cables

Route the generator cable away from other cable routes. It is recommended that the generator cable, grid cable and control cables are installed on separate trays. Avoid long parallel runs of generator cables with other cables in order to decrease electromagnetic interference caused by the rapid changes in the converter output voltage.

Where control cables must cross power cables make sure they are arranged at an angle as near to 90° as possible. Do not run extra cables through the converter.

The cable trays must have good electrical bonding to each other and to the grounding electrodes. You can use aluminum tray systems to improve local equalizing of potential.

A diagram of the cable routing is below.

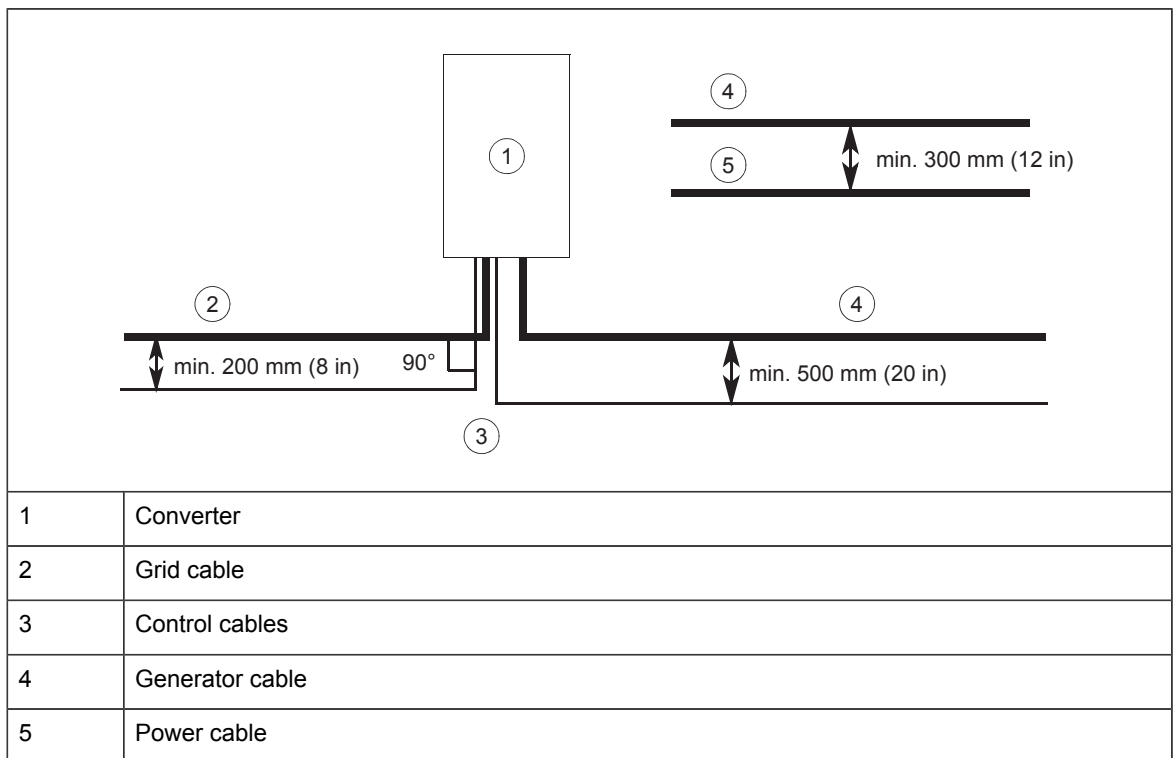

## ■ Control cable ducts

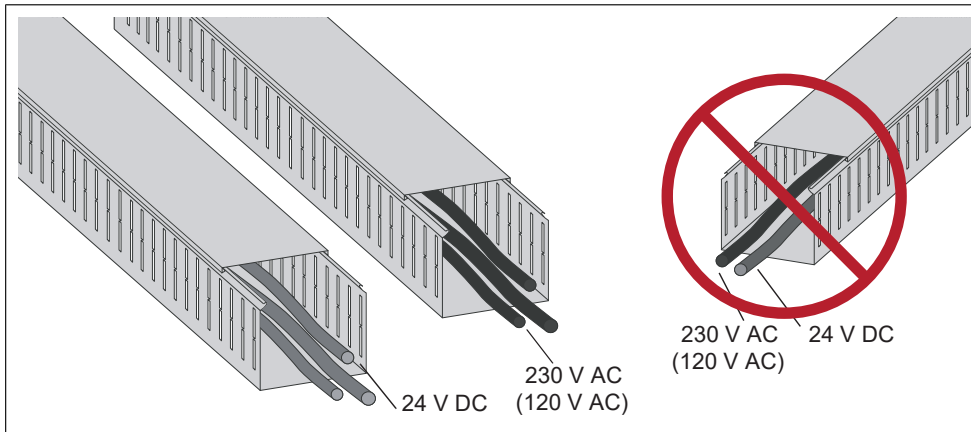

Picture on the left: Lead 24 V and 230/120 V control cables in separate ducts into the inside of the cabinet.

Picture on the right: Not allowed unless the 24 V cable is insulated for 230 V (120 V) or insulated with an insulation sleeving for 230 V (120 V).

## Protecting the converter installation

### ■ Protecting the grid cable in short-circuit situations

Equip the cable with fuses. Size the fuses according to local safety regulations, appropriate voltage and the rated current of the converter.

### ■ Protecting the generator and generator cable in short-circuit situations

The converter protects the generator cable and the generator in a short-circuit situation when the generator cable is sized according to the nominal current of the converter. No additional protection devices are needed.

### ■ Protecting the converter, generator cable and grid cable against thermal overload

The converter protects itself, the grid cables and generator cables against thermal overload when the cables are sized according to the nominal current of the converter and ambient conditions are within the limits specified under ambient conditions in the technical data. No additional thermal protection devices are needed.

### ■ Protecting the converter against ground faults in the generator or generator cable

Both the grid-side converter and generator-side converter are equipped with an internal ground fault protective function to protect them against ground faults in the converter itself, the generator and generator cable. (This is not a personal safety or a fire protection feature.) You can disable both ground fault protective functions (not recommended); refer to the firmware manual.

## ■ **Protecting the converter against ground faults in the converter or grid cable**

Both the grid-side converter and generator-side converter are equipped with an internal ground fault protective function to protect them against ground faults in the converter itself and grid cable. (This is not a personal safety or a fire protection feature.) You can disable both ground fault protective functions (not recommended); refer to the firmware manual.

## **Implementing the emergency stop function**

For further information, contact your local ABB representative.

## **Implementing the grid fault ride-through function**

See the firmware manual.

## **Supplying power for the auxiliary circuits**

The converter is not equipped with an auxiliary voltage transformer.

## **Using a safety switch between the converter and generator**

To minimize the emission level when safety switches are installed in the generator cable between the converter and the generator:

- Install the equipment in a metal enclosure in a way that the conduit or generator cable shielding runs consistently without breaks from the converter to the generator.

## **Protecting the contacts of relay outputs**

Inductive loads (such as relays, contactors and generators) cause voltage transients when switched off.

The relay contacts of the control board are protected with varistors (250 V) against overvoltage peaks. In spite of this, it is highly recommended to equip inductive loads with noise attenuating circuits (varistors, RC filters [AC] or diodes [DC]) in order to minimize the EMC emission at switch-off. If not suppressed, the disturbances may connect capacitively or inductively to other conductors in the control cable and form a risk of malfunction in other parts of the system.

Install the protective component as close to the inductive load as possible. Do not install the protective components at the terminal block.

---

64 Planning the electrical installation

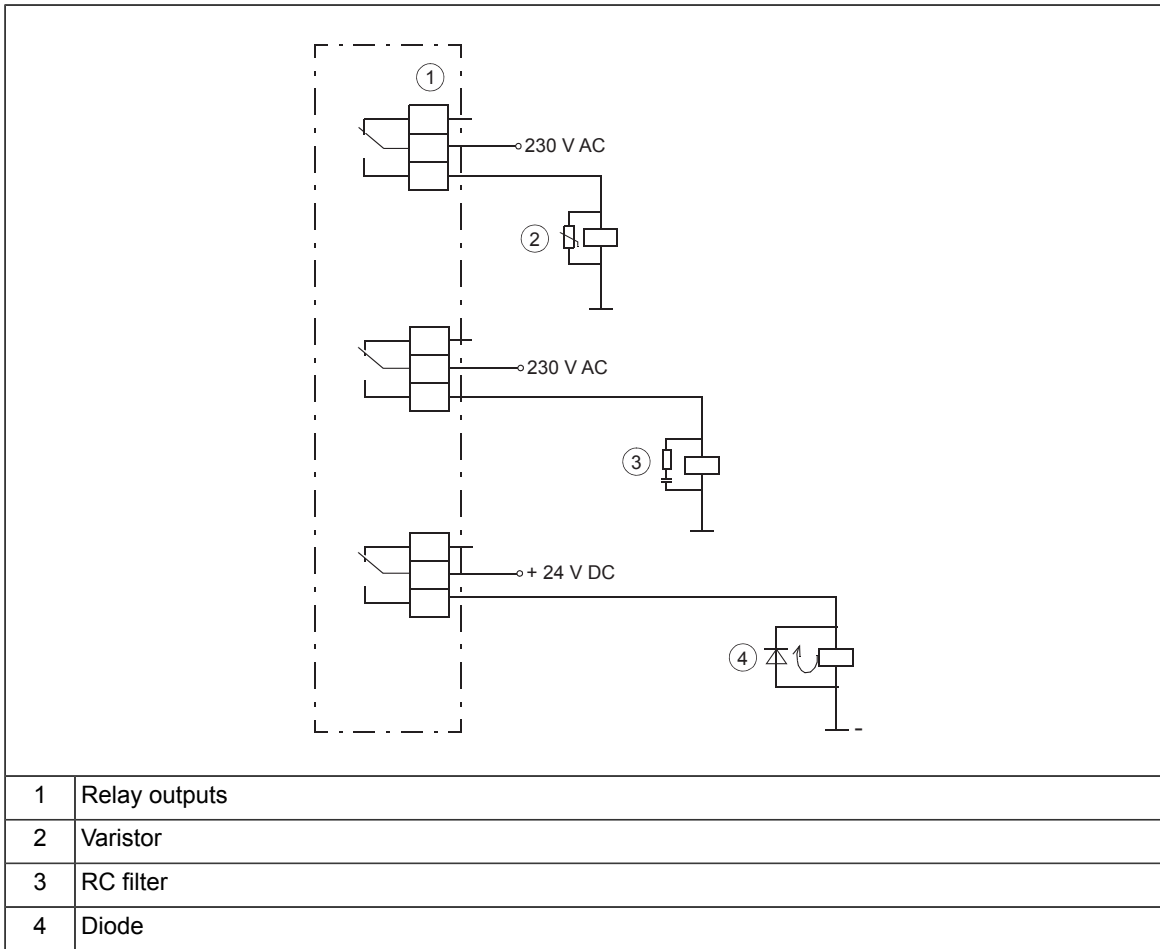

# 6

## Electrical installation

---

### Contents of this chapter

This chapter describes the electrical installation procedure of the wind turbine converter.

**WARNING!**

Only qualified electricians are allowed to carry out the work described in this chapter. Read the complete safety instructions of the converter. If you ignore them, injury or death, or damage to the equipment can occur.

---

See the circuit diagrams delivered with the converter. The diagrams of this chapter do not necessarily match the installation-specific circuit diagrams of a tailor-made wind turbine converter.

### Checking the insulation of the assembly

---

**WARNING!**

See and obey the safety instructions of the converter. If you ignore them, injury or death, or damage to the equipment can occur.

---

#### ■ Converter

Every converter has been tested for insulation between the main circuit and the chassis at the factory. Also, there are voltage-limiting circuits inside the converter which cut down the testing voltage automatically.

#### ■ Grid cable

Check the insulation of the grid cable according to local regulations before connecting it to the converter.

---

### ■ Generator stator and generator cable

Check the insulation of the generator stator and cable as follows:

- Check that all cables are disconnected from the converter output terminals U2, V2 and W2.
- Measure the insulation resistance between each phase conductor and the protective ground conductor using a measuring voltage of 1000 V DC. The insulation resistance of an ABB generator must exceed 100 Mohm (reference value at 25 °C (77 °F)). For the insulation resistance of other generators, please consult the manufacturer’s instructions.
- **Note:** Make sure that there is no condensed moisture inside the generator casing. If you suspect that there is moisture, dry the generator before measurement.
- **Note:** When using permanent magnet generator, it must be stable at the time of the measurement.

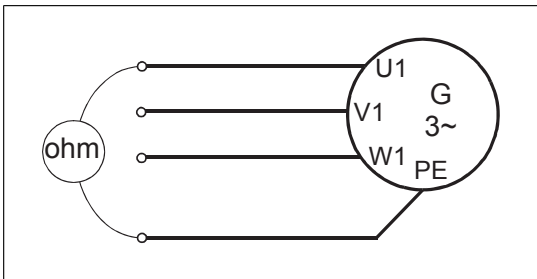

## Connecting the grid cables

### ■ Connection diagram

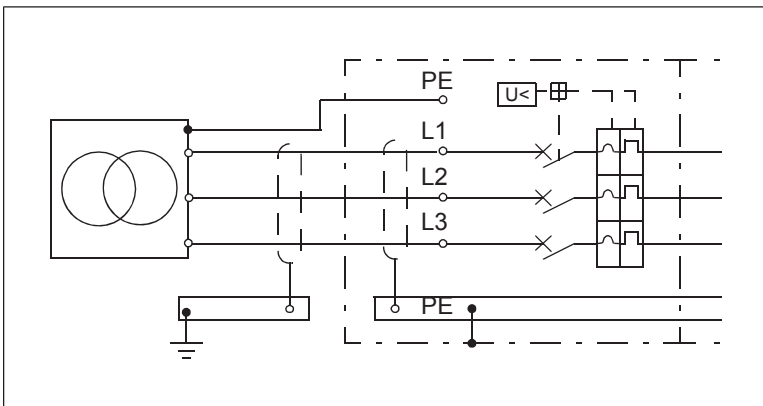

## ■ Connection procedure

**WARNING!**

See and obey the safety instructions of the converter. If you ignore them, injury or death, or damage to the equipment can occur.

**WARNING!**

Apply grease to stripped aluminum conductors before attaching them to non-coated aluminum cable lugs. Obey the grease manufacturer's instructions. Aluminum-aluminum contact can cause oxidation in the contact surfaces.

1. Open the door of the main breaker cubicle. Unlock the handle, release it from the holder and turn upwards to release the door locking mechanism.
2. Remove the shroud that protects the grid cable terminals.
3. Lead the grid cables into the inside of the cubicle.
4. Fasten the grid cables to the grid connection terminals. Connect the phase conductors to terminals L1, L2 and L3. Tighten the conductors to 120 N·m (89 lbf·ft).
5. Connect ground conductors or cables to the cabinet PEN (ground) busbar.
6. Provide support for the connections whenever necessary.
7. Refit all shrouds removed earlier.
8. Close the door.

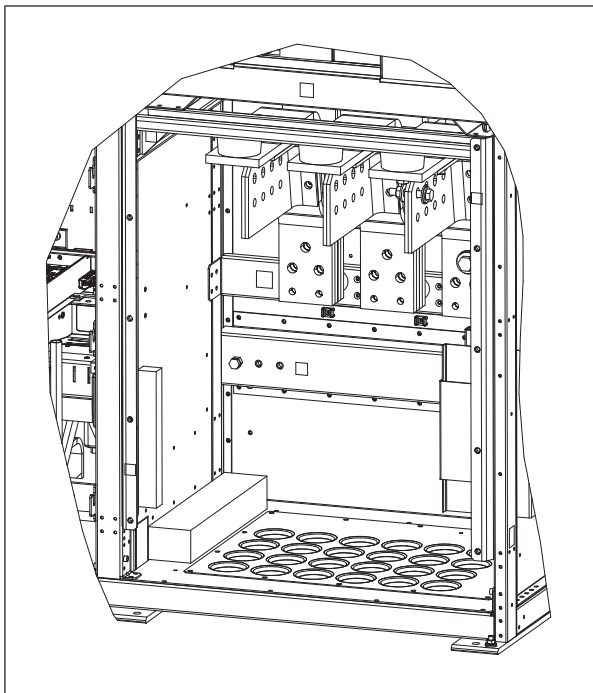

## Connecting the generator cables

### ■ Connection diagram

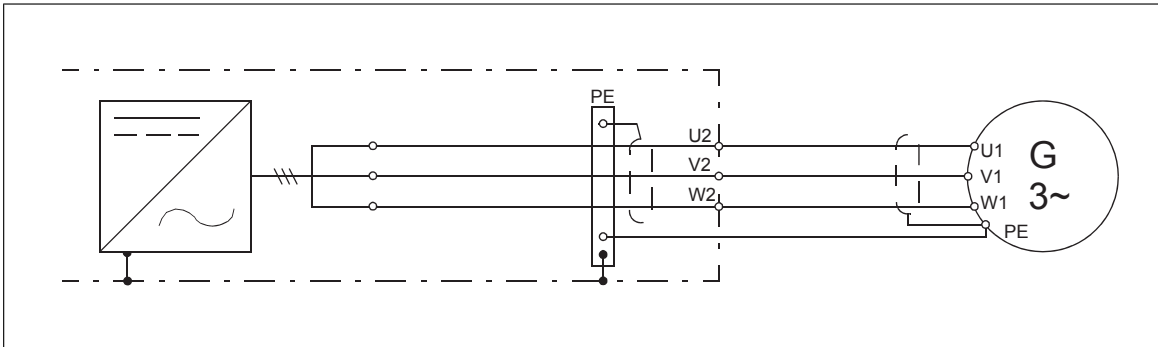

### ■ Connection procedure



**WARNING!**

See and obey the safety instructions of the converter. If you ignore them, injury or death, or damage to the equipment can occur.



**WARNING!**

Apply grease to stripped aluminum conductors before attaching them to non-coated aluminum cable lugs. Obey the grease manufacturer's instructions. Aluminum-aluminum contact can cause oxidation in the contact surfaces.

1. Open the door of the generator cable connection cubicle.
2. Remove the shroud that protects the generator cable connection busbars and cable entries.
3. Ensure that foreign objects (screws, etc.) cannot fall inside the converter module. Ensure that the cover on top of the converter modules is installed.



**WARNING!**

Foreign objects inside the converter module can cause eg, short-circuit. Injury or death, or damage to the equipment can occur.





4. When shielded cable is used:

- Lead the cables into the inside of the cubicle. Ground a shielded cable 360° at the lead-through with an EMC cable gland (to be supplied by the customer).
- Connect the cables as follows:
  - Cut the cables to suitable length. Strip the cables and conductors. Fasten the cable lugs to the conductor ends.
  - Twist the cable shields into bundles and connect to the cabinet PE (ground) busbar. Connect any separate ground conductors or cables to the cabinet PE (ground) busbar.
  - Connect the phase conductors to terminals U2, V2 and W2. See the connection diagram above. Tighten the phase conductors and PE to 120 N·m (89 lbf·ft) torque.

When single-core cables without metal shield are used:

- Lead the cables into the inside of the cubicle through the IP sealing glands.
  - Connect the phase conductors to terminals U2, V2 and W2, and the PE conductors to the PE terminal. Tighten the phase and PE conductors. For the tightening torques, see the technical data.
5. Provide support for the cables whenever necessary.
6. Clean the cover on top of the converter modules by eg. vacuum cleaning. Then remove the cover.



**WARNING!**

The cover on top of the converter modules can cause overheating. Injury or death, or damage to the equipment can occur.

7. Refit the shroud removed earlier and close the door.
8. Connect the generator end of the cable. For minimum radio frequency interference and generator bearing current, ground the cable shield 360° at the lead-through of the generator terminal box. For the generator specific instructions, see the manufacturer's user manual.

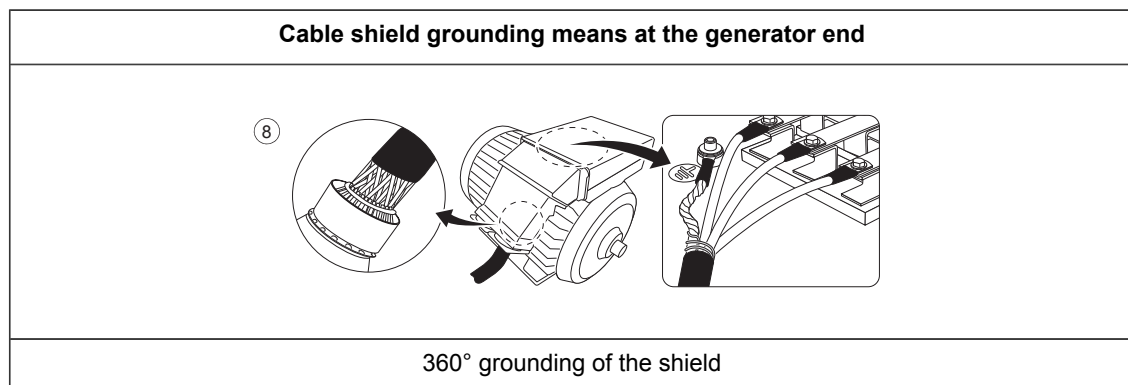

70 *Electrical installation*

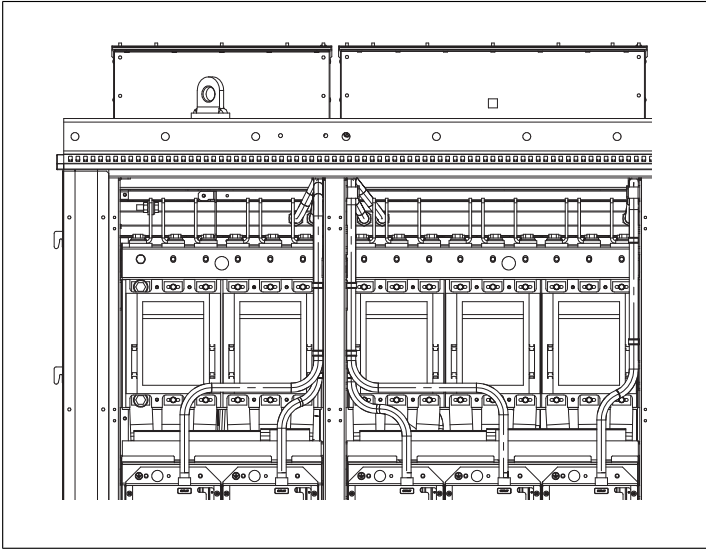

## Connecting the external power supply cable for the auxiliary circuit

Customer connection for the auxiliary power output (X11) is located on the cabinet wall.

Connector X11 on the cabinet wall



## Connecting the control cables

Control cable connectors are located in the control cubicle and on the cabinet roof (see the layout drawings). See the circuit diagrams delivered with the converter.

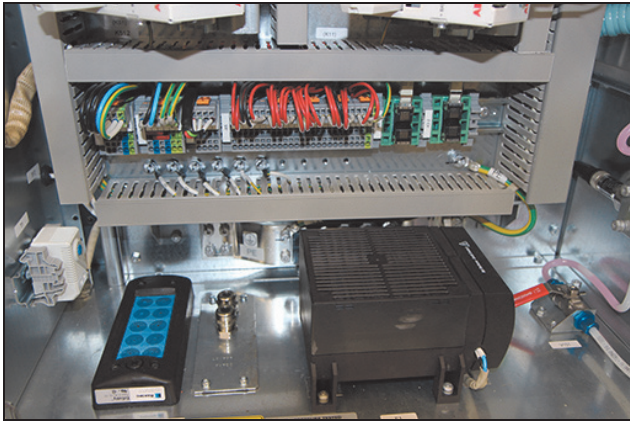
Control connections in the control cubicle	
	
Connector	Description
X1	Customer connection for 400 V AC non-UPS auxiliary power supply
X2	Customer connection for 230 V AC UPS auxiliary power supply
X3.1	Customer connection for Ethernet
X3.2	Master-slave Ethernet connection
X4	Customer connection for fieldbus
X5	Customer connection for I/O
X11	Customer connection for auxiliary power output

### ■ Default I/O connection diagrams

See the circuit diagrams delivered with the converter.

# 7

## Installation checklist

---

### Contents of this chapter

This chapter contains instructions for checking the installation of the wind turbine converter.

### Before you start

Check the mechanical and electrical installation of the converter before start-up. Go through the checklist together with another person.



#### **WARNING!**

Only qualified electricians are allowed to carry out the work described below. Do the tasks described in the safety instructions of the converter. If you ignore them, injury or death, or damage to the equipment can occur.

- 
1. Open the main disconnecter of the converter and lock it to open position.
  2. Ensure by measuring that the converter is not powered.
-

## Checklist

<b>Make sure that ...</b>	<input checked="" type="checkbox"/>
The ambient operating conditions meet the specifications given in the technical data.	<input type="checkbox"/>
The converter has been fixed properly on an even, horizontal and non-flammable floor and if necessary due to vibration etc, also from top to the wall or roof.	<input type="checkbox"/>
The cooling circuit joints are tight.	<input type="checkbox"/>
All bleed and drain valves have been closed.	<input type="checkbox"/>
The internal cooling circuit has been filled with coolant that meets the specification.	<input type="checkbox"/>
The internal cooling circuit has been bled.	<input type="checkbox"/>
The cooling air flows freely.	<input type="checkbox"/>
The filters of the door air inlets are installed.	<input type="checkbox"/>
There is an adequately sized protective earth (ground) conductor between the converter and the main grounding busbar of the wind turbine.	<input type="checkbox"/>
The generator is properly grounded.	<input type="checkbox"/>
All protective earth (ground) conductors have been connected to the appropriate terminals and the terminals have been tightened (pull the conductors to check).	<input type="checkbox"/>
The voltage of the grid transformer matches the nominal voltage of the grid-side converter. Check the type designation label.	<input type="checkbox"/>
The grid cable or grid busbars have been connected to the appropriate terminals, the phase order is right, and the terminals have been tightened. (Pull the conductors to check.) For tightening torques, see the technical data.	<input type="checkbox"/>
The generator cable has been connected to the appropriate terminals, the phase order is right, and the terminals have been tightened. (Pull the conductors to check.) For tightening torques, see the technical data.	<input type="checkbox"/>
The generator cable (and DC resistor cable, if present) has been routed away from other cables.	<input type="checkbox"/>
<u>Converters which have a DC chopper (option +D150) with a customer-acquired and installed DC resistor:</u> The DC resistor has been installed, connected to the appropriate terminals, and the terminals have been tightened. (Pull the conductors to check.) Test the DC resistor installation by measuring. Measure the resistance of each DC resistor from the cabinet DC resistor connectors. Ensure that the resistance value is within the allowed minimum and maximum values defined for the chopper circuit.	<input type="checkbox"/>
The control cables have been connected to the appropriate terminals, and the connections are tight. (Pull the conductors to check.)	<input type="checkbox"/>
There are no tools, foreign objects or dust from drilling inside the converter.	<input type="checkbox"/>
The cover for cabling protection on top of the generator-side converter modules has been removed.	<input type="checkbox"/>
All shrouds and cover of the generator connection box are in place. Cabinet doors have been closed.	<input type="checkbox"/>
The converter is ready for start-up.	<input type="checkbox"/>



# Maintenance

---

## Contents of this chapter

This chapter contains preventive maintenance intervals and instructions.

## Maintenance intervals

The table below shows the maintenance tasks which can be done by the end user. For more information, consult your local ABB Service representative ([www.abb.com/searchchannels](http://www.abb.com/searchchannels)).

---

Maintenance task/object	Years from start-up													
	0	1	2	3	4	5	6	7	8	9	10	11	12	...
<b>Replacement</b>														
Cooling fans								R						
Water-glycol coolant with inhibitor (see <b>Note 1</b> below)			I		I		R		I		I		R	
Memory backup battery in the BCU control unit		I	I	I	I	I	R	I	I	I	I	I	R	
ABB-SACE main circuit breaker maintenance (see <b>Note 2</b> below)		P	P	P	P	P	R	P	P	P	P/R	P	P	
Cooling station pump and thermos valve		I	I	I	I	R	I	I	I	I	R	I	I	
<b>Inspection and/or performance</b>														
Cabinet door air filters (change interval depends on cleanliness of ambient air)		I/R	I/R	I/R	I/R	I/R	I/R	I/R	I/R	I/R	I/R	I/R	I/R	
Cooling liquid pipe connections		I	I	I	I	I	I	I	I	I	I	I	I	
Fiber optic cables (connections)				I			I			I			I	
Tightness of terminals				P			P			P			P	
Quick connector of the converter module				I			I			I			I	
Condition of contactors		I	I	I	I	I	I	I	I	I	I	I	I	
Checking ambient conditions (dustiness, corrosion, temperature)		I	I	I	I	I	I	I	I	I	I	I	I	
Checking the quality of auxiliary voltage		I	I	I	I	I	I	I	I	I	I	I	I	
Visual check for LCL filter capacitors		I	I	I	I	I	I	I	I	I	I	I	I	
<b>Improvements</b>														
Firmware and hardware upgrade based on product notes		I	I	I	I	I	I	I	I	I	I	I	I	
<b>Measurements and tests</b>														
Functional test with net voltage		P	P	P	P	P	P	P	P	P	P	P	P	
Basic measurements with supply voltage		P	P	P	P	P	P	P	P	P	P	P	P	
<b>Spare parts</b>														
Spare parts		I	P	I	P	I	P	I	P	I	P	I	P	

3AXD10000871438

## Symbols

- I** Inspection (visual inspection and maintenance action if needed)
- P** **Performance** of on/off-site work (commissioning, tests, measurements or other work)
- R** **Replacement**

Maintenance and component replacement intervals are based on the assumption that the equipment is operated within the specified ratings and ambient conditions. ABB recommends annual inspections to ensure the highest reliability and optimum performance.



Long term operation near the specified maximum ratings or ambient conditions may require shorter maintenance intervals for certain components. Consult your local ABB Service representative for additional maintenance recommendations.

**Note 1:** Cooling liquid to be used is BASF Glysantin® G30®, Valvoline Zerex G30®, Mobil Antifreeze Advanced or CLASSIC KOLDA UE G30 FG (1:1) READY MIX mixed with demineralized or distilled water. Clean tap water can also be used. For more details, see chapter *Cooling and heating*. In case practical examples or specific tests carried with the above mentioned cooling mixture together with the cooling system materials, the maintenance interval can be revised.

**Note 2:** The maintenance schedule of the main circuit breaker is according to maximum 1,000 operations of the breaker per each year. Replacement after 10000 operations. For more information, refer to the maintenance manual of the ABB SACE breaker.

## Maintenance timers and counters

The control program has maintenance timers and counters that can be configured to generate a warning when a pre-defined limit is reached. Each timer/counter can be set to monitor any parameter. This feature is especially useful as a service reminder. For more information, see the firmware manual.

## Cabinet

### ■ Cleaning the door air inlets



#### **WARNING!**

Use a vacuum cleaner with antistatic hose and nozzle, and wear a grounding wristband. Using a normal vacuum cleaner creates static discharges which can damage circuit boards.

Check the dustiness of the air inlet meshes. If the dust cannot be removed by vacuum cleaning from outside through the grating holes with a small nozzle, proceed as follows:

1. De-energize the fans by switching off the converter. Obey the safety instructions.
2. Remove the fasteners at the top of the grating. Air inlets with support plate: Remove all the fasteners from the support plate on top of the grating and remove the support plate.
3. Lift the grating and pull it away from the door.
4. Vacuum clean or wash the grating on both sides. Replace the filter mat with a new one.
5. Reinstall the grating in reverse order.

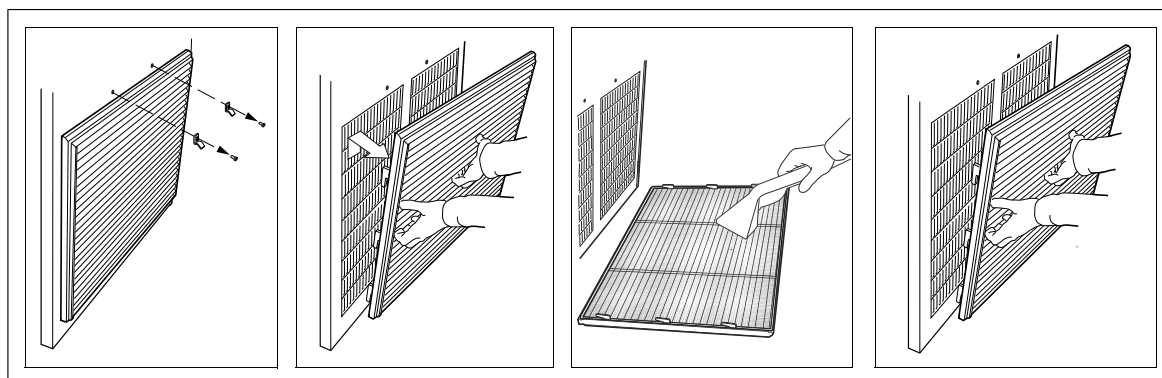

### ■ **Cleaning the door air inlets and outlets (auxiliary control cubicle)**

Check the dustiness of the air inlet meshes. If the dust cannot be removed by vacuum cleaning from outside through the grating holes with a small nozzle, proceed as follows:

1. De-energize the fans by switching off the converter. Obey the safety instructions.
2. Remove the fasteners at the top of the grating. Air inlets with support plate: Remove all the fasteners from the support plate on top of the grating and remove the support plate.
3. Lift the grating and pull it away from the door.
4. Remove the air filter.
5. Place the new filter in the grating the metal wire side facing the door.
6. Reinstall the grating in reverse order.

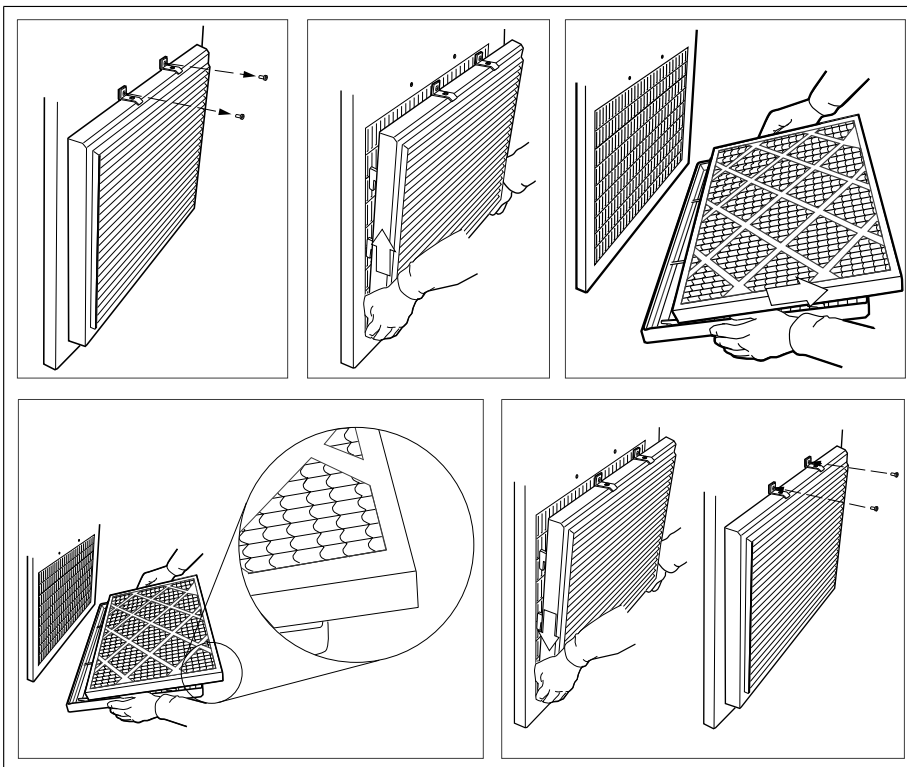

### ■ **Cleaning the outlet (door or roof) filters**

The outlet (door or roof) filter can be accessed by pulling the grating upwards.

## **Power connections**

### ■ **Tightening**



#### **WARNING!**

Only qualified electricians are allowed to do this work. Read the complete safety instructions of the converter. If you ignore the instructions, physical injury, death, or damage to the equipment can occur.

1. Disconnect the converter from the all power sources and make sure it is safe to start the work. See the safety instructions.
2. Check the tightness of the cable connections. Use the tightening torques given in the technical data.

## Fans

The lifespan of the cooling fans of the converter depend on the running time of the fan, ambient temperature and dust concentration. See the firmware manual for the parameter or actual value which indicates the running time of the cooling fan of the converter modules. For resetting the running time after a fan replacement, contact ABB.

Replacement fans are available from ABB. Do not use other than ABB specified spare parts. All the fans in the converter are of the same type.

### ■ Replacing the cooling fan of the converter module

---



#### **WARNING!**

Only qualified electricians are allowed to do this work. Read the complete safety instructions of the converter. If you ignore the instructions, physical injury, death, or damage to the equipment can occur.

---

1. Disconnect the converter from the all power sources and make sure it is safe to start the work. See the safety instructions.
  2. Cooling fan of the converter module (a) is located below the module. Open the door of the converter module cubicle and remove the shroud in front of the fan.
  3. Disconnect the wiring plug of the fan (b).
  4. Remove the fastening screws (c) of the fan support.
  5. Lift the fan unit out of the cabinet.
  6. Detach the fan from the support plate by loosening the fastening screws of the fan. The fan grille is detached then too.
  7. Install a new fan in reverse order. Check that the air flow direction is correct (an arrow indicating the direction is marked on the side of the fan). Remember to install the fan grille before lifting the fan into the cabinet.
-

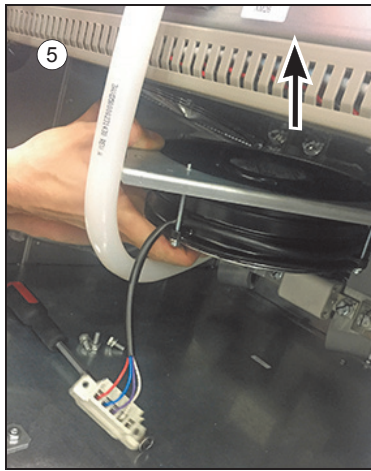
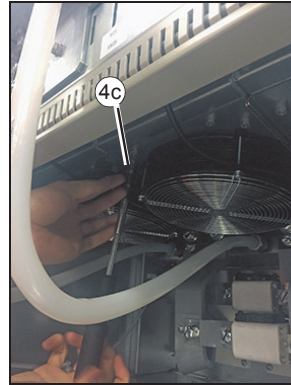
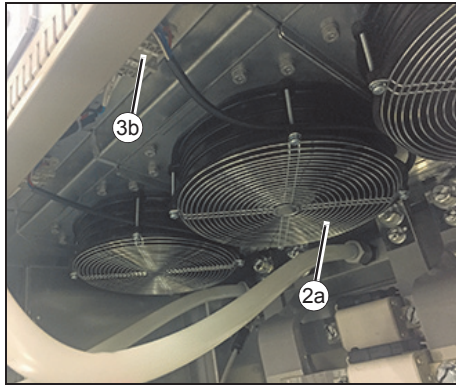

Air flow direction is towards the converter module.

## ■ Replacing the fan of the main breaker cubicle



### **WARNING!**

Only qualified electricians are allowed to do this work. Read the complete safety instructions of the converter. If you ignore the instructions, physical injury, death, or damage to the equipment can occur.

Disconnect the converter from the all power sources and make sure it is safe to start the work. See the safety instructions.

1. De-energize the fans by switching off the converter. Obey the safety instructions.
2. The cooling fan of the main breaker cubicle is located on the cabinet door. Remove all the fasteners from the support plate on top of the grating and remove the support plate.
3. Lift the grating and pull it away from the door.
4. Remove the air filter.
5. Remove all the fasteners from the inner grating and remove it.
6. Disconnect the wiring plug of the fan.
7. Undo the four fastening screws of the fan. The fan grille is detached then too.
8. Pull the fan out.
9. Install a new fan in reverse order. Check that the air flow direction is correct (an arrow indicating the direction is marked on the side of the fan).
10. Reinstall the filter and grating in reverse order. Check that the filter orientation is correct (an arrow indicating the air flow direction is marked on the side of the filter).

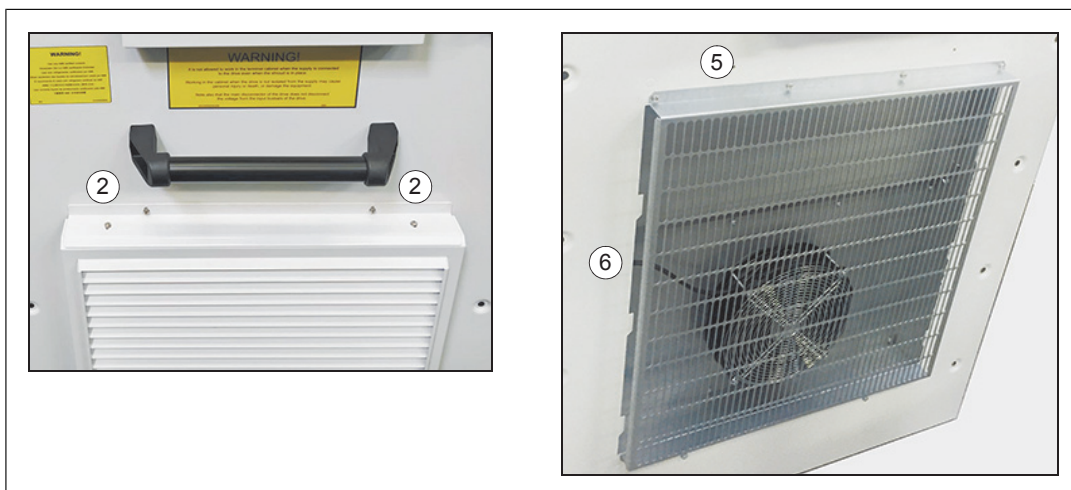

## ■ Replacing the cooling fan of the auxiliary control cubicle



### **WARNING!**

Only qualified electricians are allowed to do this work. Read the complete safety instructions of the converter. If you ignore the instructions, physical injury, death, or damage to the equipment can occur.

1. Disconnect the converter from the all power sources and make sure it is safe to start the work. See the safety instructions.
2. The cooling fan of the auxiliary control cubicle is located in the lower part of the cubicle. Open the door of the auxiliary control cubicle.
3. Disconnect the wiring plug of the fan.
4. Undo the four fastening screws of the fan. The fan grille is detached then too.
5. Pull the fan out.
6. Install a new fan in reverse order. Check that the air flow direction is correct (an arrow indicating the direction is marked on the side of the fan).

**Control cubicle door**

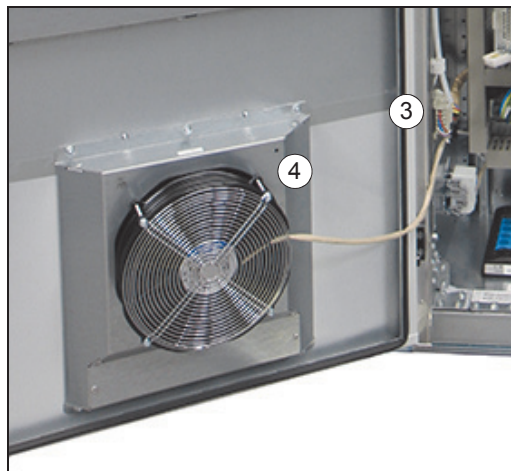

Air flow circulation is towards the cabinet.



## ■ Replacing the cooling fan of the LCL filter cubicle



### WARNING!

Only qualified electricians are allowed to do this work. Read the complete safety instructions of the converter. If you ignore the instructions, physical injury, death, or damage to the equipment can occur.

1. Disconnect the converter from the all power sources and make sure it is safe to start the work. See the safety instructions.
2. Open the door of the LCL filter cubicle. The cooling fans of the LCL filter cubicle are located in the lower part of the cubicle.
3. Disconnect the wiring plug of the fan (a).
4. Undo the fastening screws of the fan (b). The fan grille is detached then too.
5. Pull the fan out.
6. Install a new fan in reverse order. Check that the air flow direction is correct (an arrow indicating the direction is marked on the side of the fan). In this case, the air flow direction is towards the inner part of the cabinet.

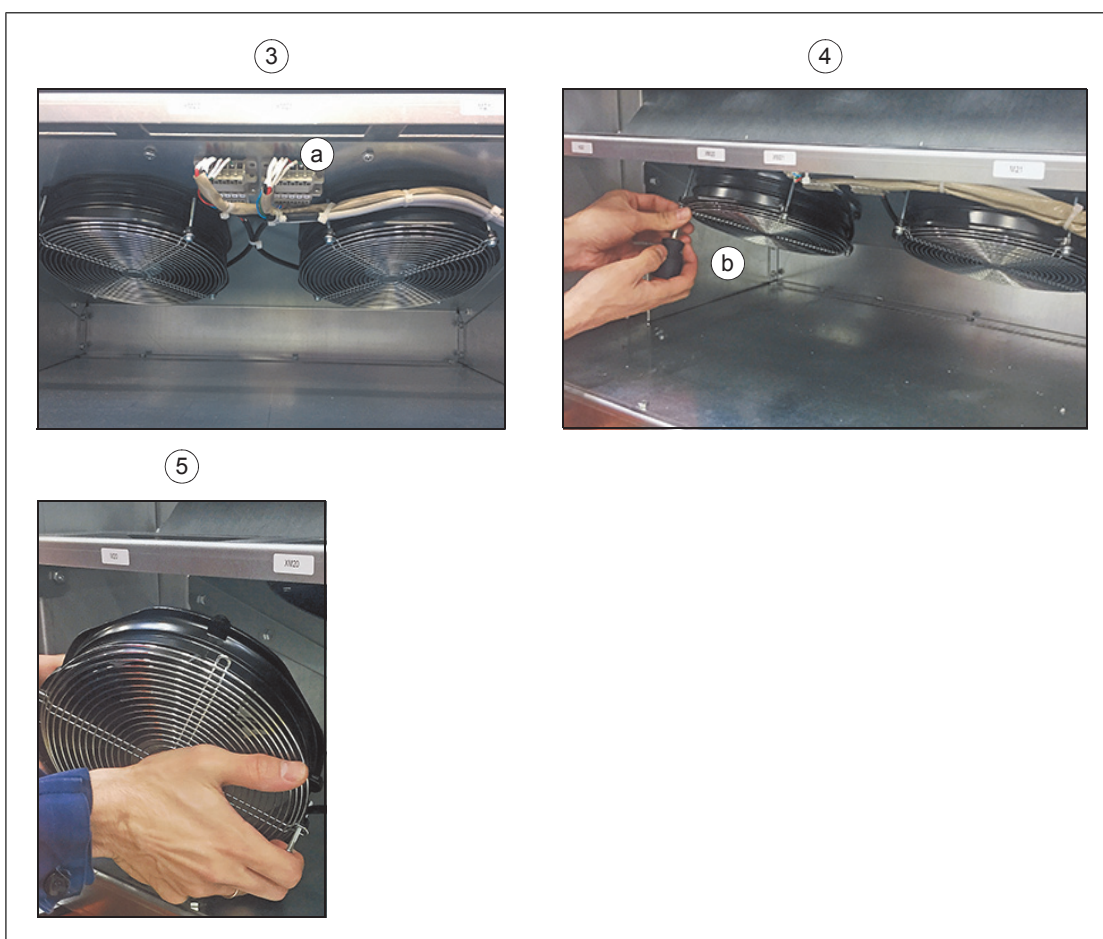

## Fuses

### ■ Replacing the DC fuses



#### **WARNING!**

Only qualified electricians are allowed to do this work. Read the complete safety instructions of the converter. If you ignore the instructions, physical injury, death, or damage to the equipment can occur.

1. Disconnect the converter from the all power sources and make sure it is safe to start the work. See the safety instructions.
2. Remove the shrouds in front of the fuses.
3. Open the M10 screws and remove the fuses.
4. Insert new fuses.
5. Re-assemble the parts in reverse order. The tightening torque for the M10 screws is 42 N·m (31 lbf·ft).

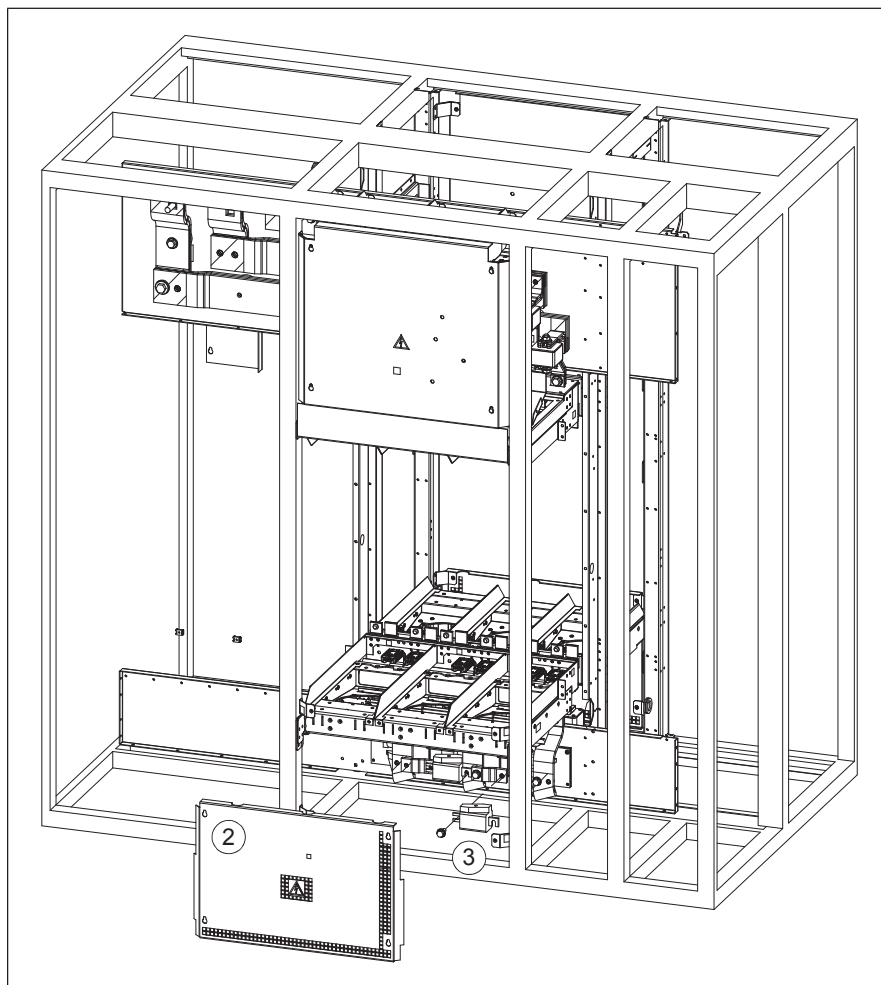



## ■ Replacing the AC fuses



### WARNING!

Only qualified electricians are allowed to do this work. Read the complete safety instructions of the converter. If you ignore the instructions, physical injury, death, or damage to the equipment can occur.

1. Disconnect the converter from the all power sources and make sure it is safe to start the work. See the safety instructions.
2. Remove the shrouds in front of the fuses.
3. Open the M10 screws and remove the fuses.
4. Insert new fuses.
5. Re-assemble the parts in reverse order. The tightening torque for the M10 screws is 42 N·m (31 lbf·ft).

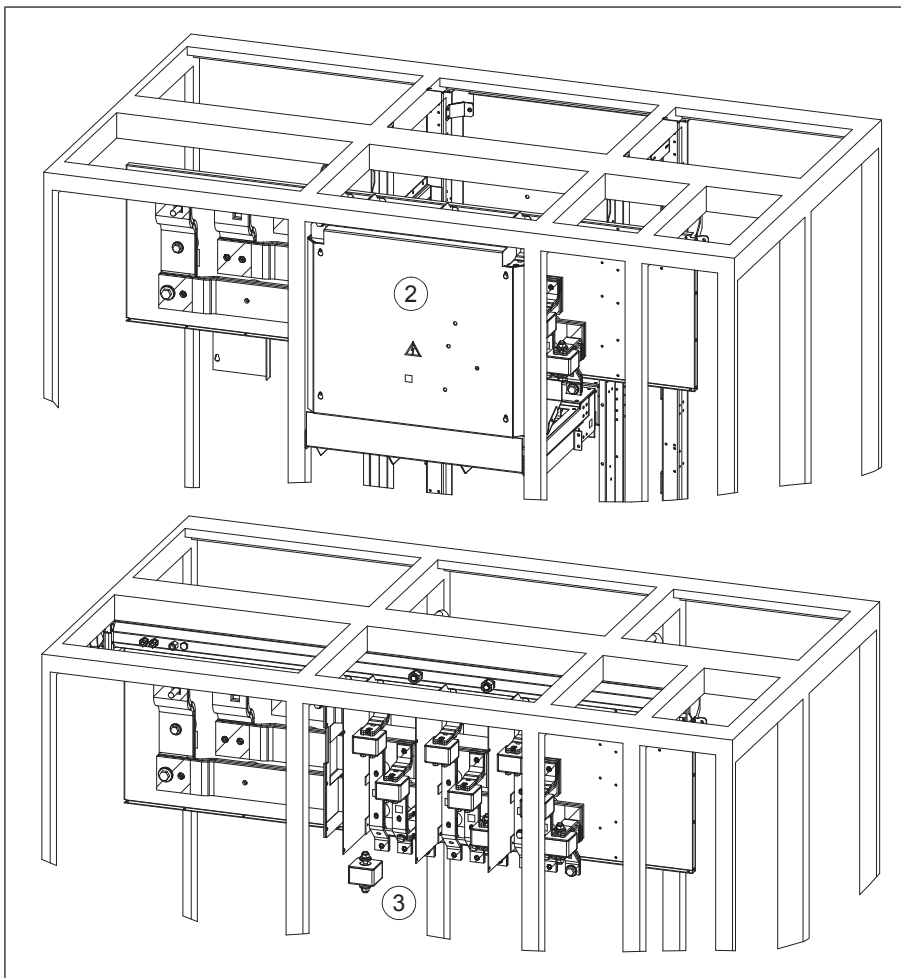

## Converter module

### ■ Replacing the converter module

---



**WARNING!**

Only qualified electricians are allowed to do this work. Read the complete safety instructions of the converter. If you ignore the instructions, physical injury, death, or damage to the equipment can occur.

---



**WARNING!**

If you ignore the following instructions, physical injury, death, or damage to the equipment can occur:

- The modules are heavy and have a high center of gravity. They topple over easily if handled carelessly.
  - When removing a module, pull the module carefully out of the cubicle along the installation stand. Prevent the module from falling.
  - Keep your fingers away from the edge of the module front plate to avoid pinching them between the module and the cubicle.
  - Use protective gloves! The edges of the module are sharp!
  - Use protective eyewear when working with the liquid cooling system.
  - Beware not to drop the screws inside the module!
  - Do not tilt the module. Do not leave the module unattended on a sloping floor.
- 

1. Disconnect the converter from the all power sources and make sure it is safe to start the work. See the safety instructions. Secure the main circuit breaker [Q1] to the disconnected position. If the disconnecting equipment is located outside the cabinet, make sure that it is in the disconnected position.

Close the inlet and outlet valves of the liquid cooling unit, and drain the cooling circuit. See the instructions on draining the internal cooling circuit.

2. Open the door of the module cubicle.
  3. Remove the shrouds on top and bottom of module cubicle.
  4. Remove the shroud supports.
  5. Remove the plastic covers in front of the fiber optic cables.
-

6. Unplug the fiber optic cables and X50 connectors. Carefully place the cables on top of the fan.

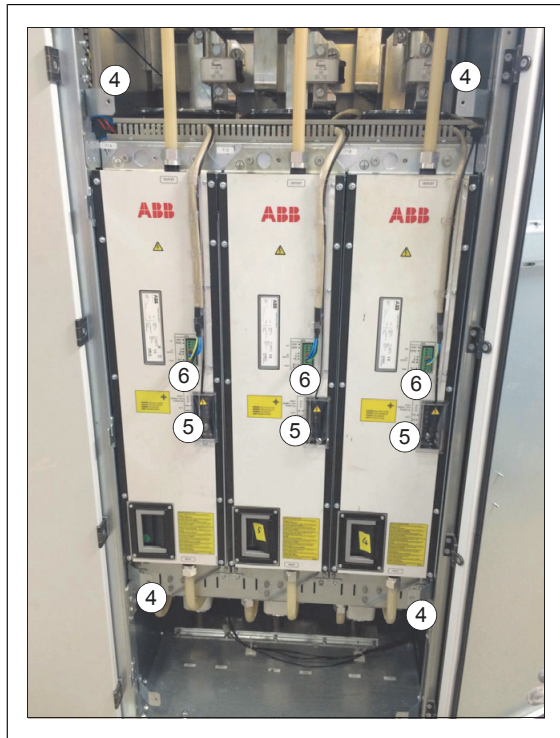

7. Remove the pipe clamps from top tubes.

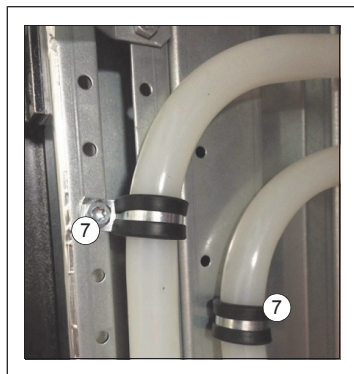

8. Open top liquid connection nut with 30 mm wrench. Pull the pipe upwards to release it.
-

9. Open two module support bolts from top.

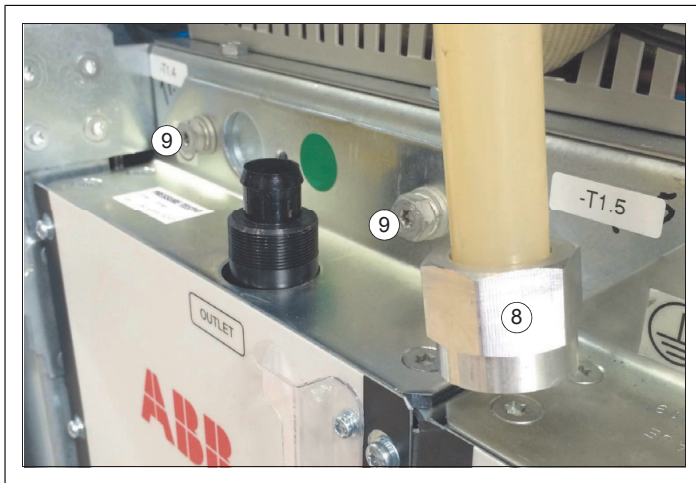

10. Open bottom liquid connection with 30 mm wrench. Pull the pipe downwards to release it.

11. Remove the module bottom support by opening 3 pcs of M6 screws and 2 pcs of M8 screws.

12. Open 2 pcs of Taptite® M6 screws.

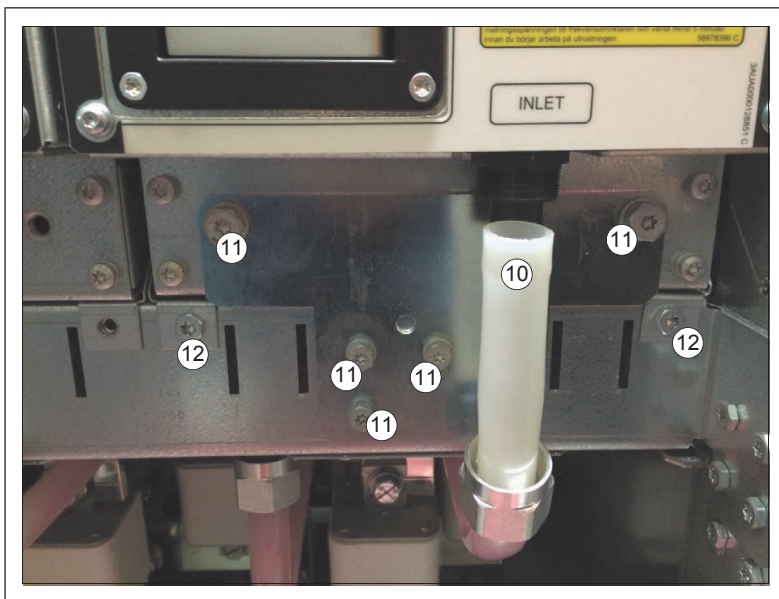

13. Open Taptite® M6 screw on the floor.

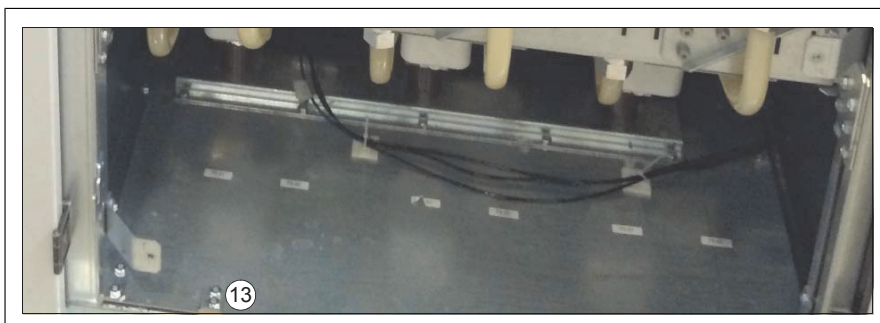

14. Open the installation stand (optional) and place it in front of the module.

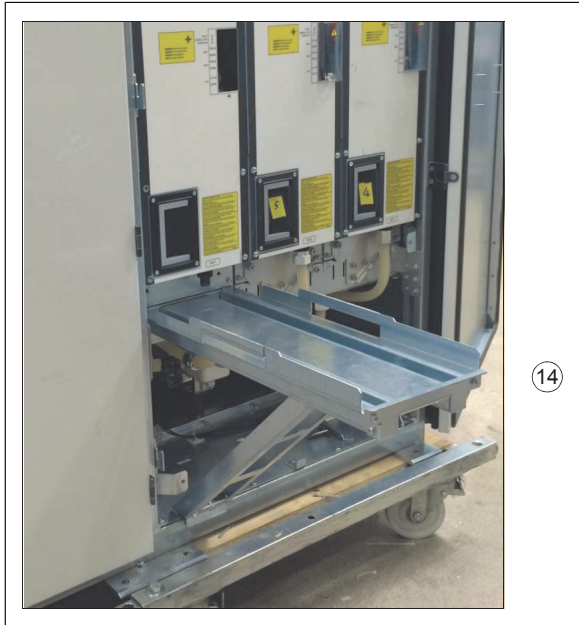

15. Install 3 pcs of M6 Taptite® screws (removed earlier) to secure the installation stand. Tightening torque is 5 N·m (3.7 lbf-ft).

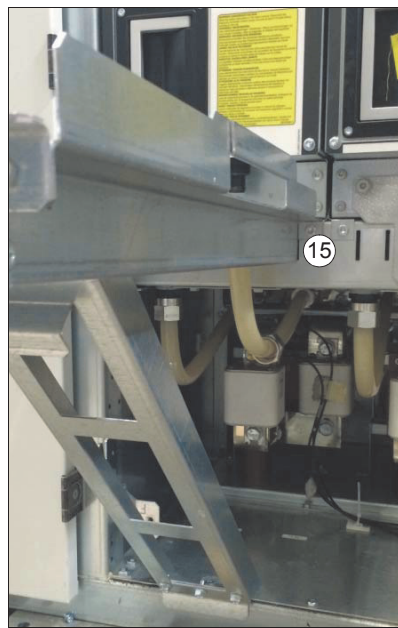
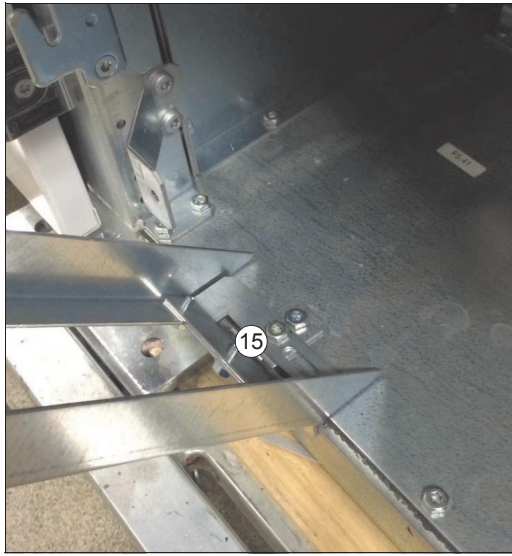



16. Insert M8 bolt to the hole on the top part of the module and turn it clockwise. This will help in pushing the module out. It also helps in pulling simultaneously from the handle while turning the screw.

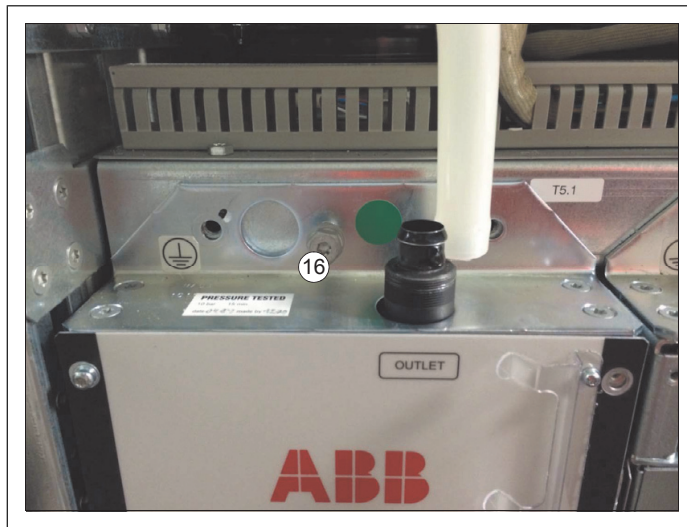

17. Pull the module out a bit (5 cm [2 in]) and install the lifting hook to the lifting hole.



18. Pull the whole module onto the installation stand. Keep the pipes and wires away from the sharp edges and be careful not to damage the coolant connections.
  19. Lift the module onto a pallet or other platform for transportation.
  20. Install a new module in reverse order. Tightening torque for cooling connectors is 10 N·m (7.4 lbf·ft) in room temperature (around +20 °C [68 °F]).
-

## Capacitors

The converter intermediate circuit employs film capacitors. Their lifespan depends on the operating time of the converter, loading and ambient temperature. Capacitor life can be prolonged by lowering the ambient temperature.

Capacitor failure is usually followed by the converter module and module fuse failure, or a fault trip. Contact ABB if capacitor failure is suspected. Replacements are available from ABB. Do not use other than ABB specified spare parts.

## BCU control unit

---



### **WARNING!**

Only qualified electricians are allowed to do this work. Do not remove or insert a memory unit when the converter is powered or the control unit is powered from an external power source.

Read the complete safety instructions of the converter. If you ignore the instructions, physical injury, death, or damage to the equipment can occur.

---

Disconnect the converter from the all power sources and make sure it is safe to start the work. See the safety instructions.

### ■ **Replacing the memory unit**

The memory unit is located on the BCU control unit.

---



### **WARNING!**

Do not remove or insert the memory unit when the control unit is powered.

---

See b in figure [Replacement illustration \(page 93\)](#).

1. To remove the memory unit, undo the fastening screw and pull the memory unit out.
2. Insert the new memory unit and fasten the screw.

### ■ **Replacing the real-time clock battery**

Replace the real-time clock battery if the BATT LED is not illuminated when the control unit is powered.

See a in figure [Replacement illustration \(page 93\)](#).

1. Undo the fastening screw and remove the battery.
2. Insert the new battery according to the figure below.
3. Dispose the old battery according to local disposal rules or applicable laws.
4. Set the real-time clock.

### ■ **Replacing the SD/SDHC memory card**

**Note:** Do not remove the SD card while the yellow WRITE LED is lit. Writing to the SD card is in progress.

See c in figure [Replacement illustration \(page 93\)](#).

---



1. Undo the fastening screw (Torx T10) of the clip covering the memory card and press the card to remove it. For the card location, see the following figure.
2. Insert the new card in reverse order. Tightening torque for fastening screw is 0.7 N·m (0.5 lbf·ft). Repeat the replacement procedure for other BCU control unit if needed.

### ■ Replacement illustration

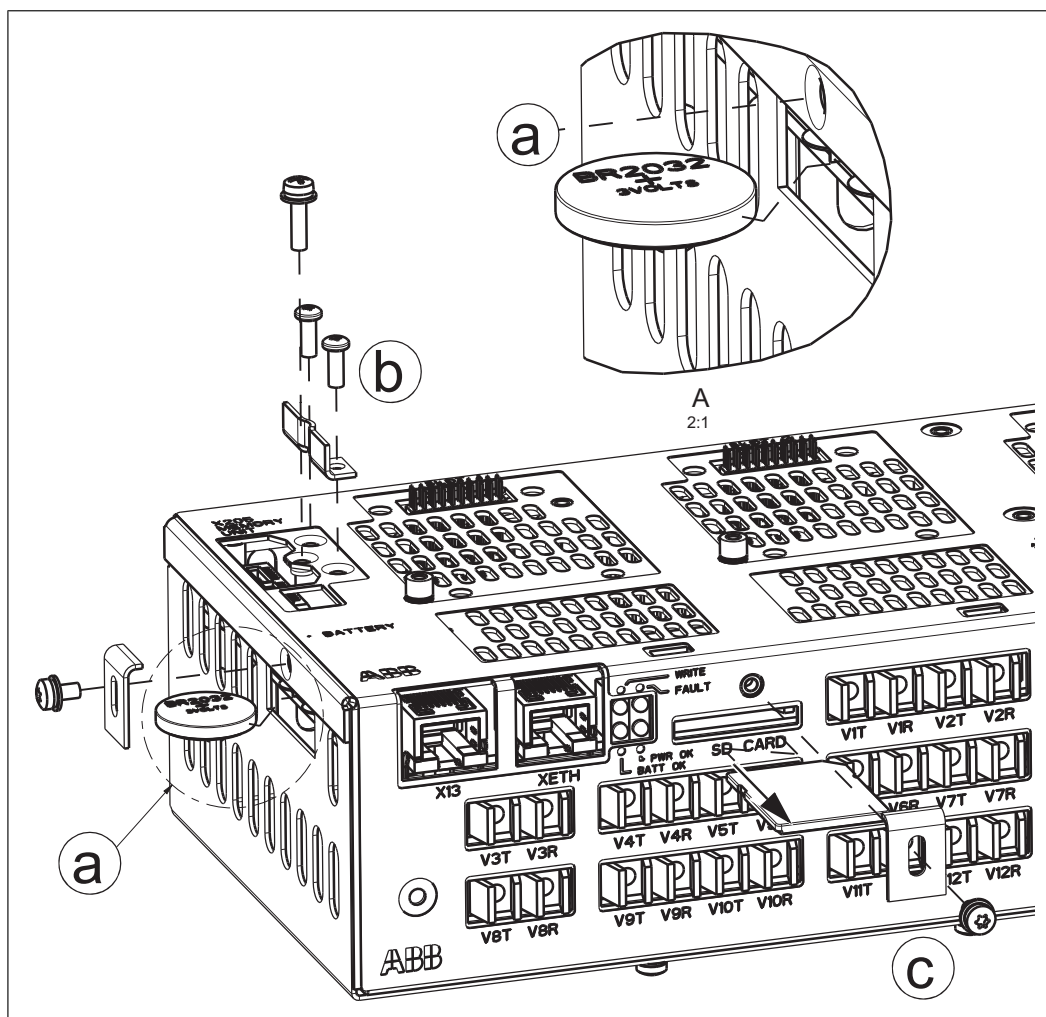

### Main circuit breaker

For ABB-SACE main circuit breaker maintenance, refer to the manufacturer's instructions (1SDH001000R0002).

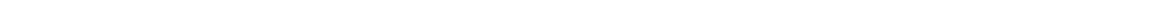

# 9

## Technical data

### Contents of this chapter

This chapter contains the technical data of the ACS880-87CC.

### Ratings

Converter type ACS880-87CC-	Generator-side converter ratings		Grid-side converter ratings			Cos phi
	$P_{gen}$	$I_2$	$P_{grid}$	$I_1$	$S_n$	
	kW	A	kW	A	kVA	
$U_N = 690\text{ V}$						
5200A/4800A-7	5345	5200	5163	4800	5737	0.9
5160A/4800A-7	5051	5160	5163	4800	5737	0.9
6880A/5500A-7	7154	6880	5916	5500	6573	0.9
3AXD10000011539						

#### ■ Definitions

##### Generator-side converter ratings

$U_N$  Nominal voltage (see also section [Grid specification \(page 99\)](#))

$P_{gen}$  Typical generator power. The power ratings apply at nominal voltage 690 V.

$I_2$  Continuous rms current of the generator-side converter

##### Grid-side converter ratings

$P_{grid}$  Rated grid-side converter power. The power ratings apply at nominal voltage 690 V.

$I_1$  Continuous rms current of the grid-side converter

$S_n$  Apparent power

Cos phi Controllable cos phi with full rated power capacity. Range: -value...+value.

## ■ Derating

The load capacity (current and power) decreases if the installation site altitude exceeds 1000 meters (3281 ft), or if the ambient temperature exceeds 45 °C (113 °F).

### Ambient temperature derating

In the temperature range +45 °C (+113 °F) ... +55 °C (+131 °F), the rated output current is decreased by 2.5% for every additional 1 °C (1.8 °F). The output current is calculated by multiplying the current given in the rating table by the derating factor.

Example If the ambient temperature is 55 °C (+131 °F), the derating factor is

$100\% - 2.5\% / ^\circ\text{C} \cdot 10\text{ }^\circ\text{C} = 75\%$  or 0.75. The output current is then  $0.75 \cdot I_{\text{gen}}$ .

For converter output current derating based on coolant inlet temperature, see section [Temperature limits \(page 129\)](#).

### Altitude derating

At altitudes above 1000 m (3281 ft) above sea level, the derating is 1% for every 100 m (328 ft) on maximum continuous current. This can be compensated by reducing maximum ambient air temperature by 1 °C (1.8 °F) for every 100 m (328 ft). Derating is allowed only on maximum continuous current for grid and generator. If the installation site is located higher than 2000 m (6562 ft) above sea level, contact your local ABB representative.

## Type equivalence table

Converter type ACS880-87CC-	Construction type	Basic module type (R9iLC)	
		Generator-side converter	Grid-side converter
	Generator-side converter modules + Grid-side converter modules+ LCL	ACS880-104LC-... (+E205)	ACS880-104LC-... (+E205)
$U_N = 690\text{ V}$			
5200A/4800A-7	2×(5×R9iLC + 3×R9iLC + 1×LCL)	0860A-7	0860A-7
5160A/4800A-7	2×(3×R9iLC + 3×R9iLC + 1×LCL)	0900A-7	0860A-7
6880A/5500A-7	2×(4×R9iLC + 4×R9iLC + 1×LCL)	0900A-7	0860A-7
			3AXD10000011539

## Fuses

### ■ Main circuit AC fuses

Converter type ACS880-87CC-	AC fuses		
	Type	$I_N$ A rms	Qty
$U_N = 690\text{ V}$			
5200A/4800A-7	Bussmann 170M6416	1250	2×9
5160A/4800A-7	Bussmann 170M6416	1250	2×9
6880A/5500A-7	Bussmann 170M6416	1250	2×12
			3AXD10000011539

### ■ Main circuit DC fuses

Converter type ACS880-87CC-	DC fuses		
	Type	$I_N$ A rms	Qty
$U_N = 690\text{ V}$			
5200A/4800A-7	Bussmann 170M6501	1400	2×16
5160A/4800A-7	Bussmann 170M6501	1400	2×6
6880A/5500A-7	Bussmann 170M6501	1400	2×8
			3AXD10000011539

### ■ Fuses for the voltage measurement board BAMU

The fuse type is Mersen FR14GR69V2T, 2 A; 2×3 pcs

### ■ Fuses of the DC chopper

The fuse type is 170M4243/PC71UD13C400D (>1000 V).

### ■ F4 fuses

The fuse type is OFAA2GG315, 315 A; 2×3 pcs.

## Dimensions, weights and free space requirements

See also chapter [Dimension drawings](#).

Converter type ACS880-87CC-	Dimensions			Weight
	Height	Depth	Width	
	mm (in)	mm (in)	mm (in)	kg (lb)
$U_N = 690\text{ V}$				
5200A/4800A-7	2300 (90.6)	1481 (58.3)	2256 (88.8)	3300 (7275)
5160A/4800A-7	2300 (90.6)	1481 (58.3)	2256 (88.8)	3100 (6834)
6880A/5500A-7	2300 (90.6)	1481 (58.3)	2256 (88.8)	3300 (7275)
				3AXD10000011539

For free space requirements, see the dimension drawings.

## Losses, cooling data and noise

Converter type ACS880-87CC-	Losses		Cooling data			Noise
	Liquid	Air	Coolant quantity	Mass flow (tolerance -2%... +20%)	Pressure loss	
	kW	kW	l	l/min	kPa	
$U_N = 690 \text{ V}$						
5200A/4800A-7	131	27	2×23	250	120	< 90
5160A/4800A-7	154	39	2×23	200	120	< 90
6880A/5500A-7	171	42	2×23	260	120	< 90
						3AXD10000011539

### ■ Internal cooling circuit data

See chapter [Cooling and heating](#).

## Terminal and lead-through data for the grid connection

Each busbar consists of two parts placed against each other. You can connect cable lugs to both sides of the connection busbar. Grid-side power connection enters the cabinet at the bottom of the cabinet.

### ■ Tightening torques

Screw size	Torque
M5	4 N·m (3 lbf·ft)
M6	9 N·m (6.6 lbf·ft)
M8	22 N·m (16.2 lbf·ft)
M10	42 N·m (31 lbf·ft)
M12	70 N·m (52 lbf·ft)
M16	120 N·m (89 lbf·ft)

For the drawings and dimensions of the grid cable terminals, see the dimension drawings.

## Terminal and lead-through data for the generator cable

You can connect cable lugs to both sides of the connection busbar. Generator cables enter the cabinet at the top of the cabinet.

Generator cable connection busbars are presented below. See also the dimension drawings.

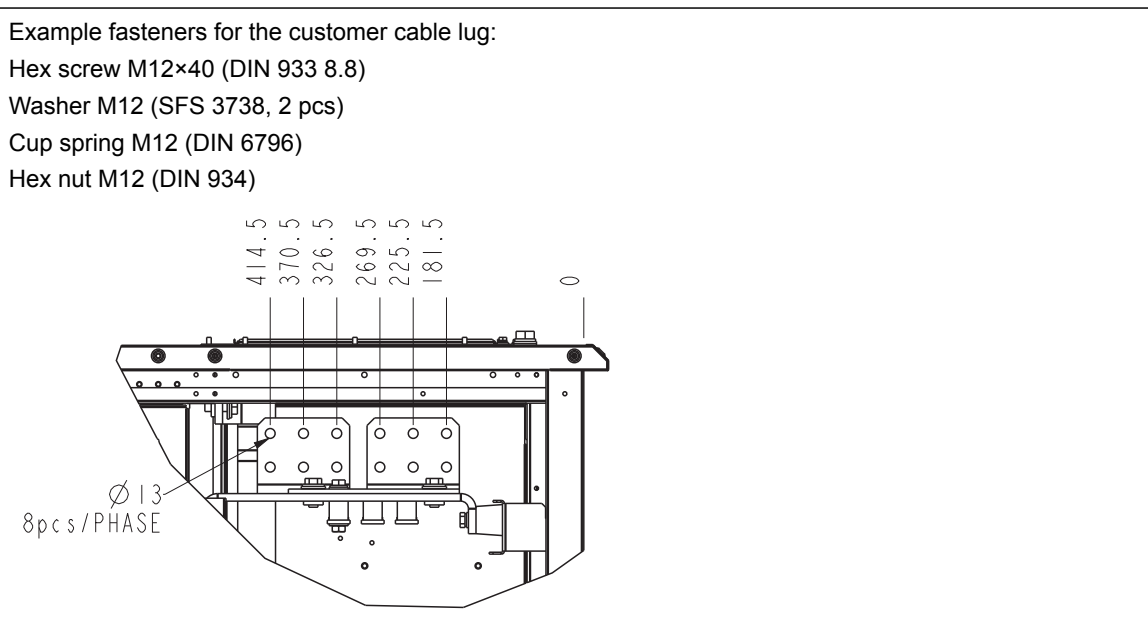

## Grid specification

Voltage ( $U_1$ )	525/550/575/600/660/690 V AC 3-phase for 690 V AC converters. This is indicated in type designation label as typical input voltage level (3~ 690 V AC). $\pm 10\%$ variation from the converter nominal voltage is allowed as default.
Frequency ( $f_1$ )	50 $\pm$ 5 Hz or 60 $\pm$ 5 Hz. Maximum rate of change 17%/s.
Maximum allowable prospective short-circuit current (IEC 60439-1, UL 508 C)	65 kA / 1 s According to UL 508C, the converter is not rated for short-circuits with a power factor less than 1.
Power factor	-1...0...1
Harmonic distortion	Total harmonic current distortion (n = 2...40) < 5%. Total harmonic voltage distortion (n = 2...40) < 5%, when $R_{sc} \geq 7$ .

## Requirements for the grid connection

For applicable grid codes, contact your local ABB representative.

## Generator connection data

Generator types	AC induction generators, permanent magnet generators
Voltage ( $U_2$ )	0...110% $U_1$ , 3-phase symmetrical, $U_{max}$ 750 V
Output frequency ( $f_2$ )	8...200 Hz
Switching frequency	2.4 kHz (average)
Frequency resolution	0.01 Hz
Current	See the ratings.
Field weakening point	8...300 Hz

## BCU control unit

See chapters [BCU-x2 control unit](#) and [BCU-x5 control unit](#).

## Efficiency

96.5% at nominal load with power factor 1.0 at 690 V.

## Degree of protection

The converter is labeled as IP21, IP2x with cubicle doors open.

## Environmental and corrosion classification

The expected lifetime for the converter cabinet enclosure is considered to be at least 20 years under the following environmental classifications and corrosion class.

### Environmental classifications in accordance with IEC60721-3-3

•Climatic conditions	3K5 <sup>1)</sup>
•Special climatic conditions	3Z11 <sup>2)</sup>
•Chemically active substances	3C2
•Mechanically active substances	3S2
•Mechanical conditions	3M1

### Corrosion class in accordance with 12944-1

- Corrosion class for the cabinet enclosure (painted surfaces, pre-treatment C3L<sup>3)</sup>  
FeP, polyester powder paint thickness 80 µm)

<sup>1)</sup> Condensation and/or formation of ice inside the converter cabinet is not allowed in any operational circumstances.

<sup>2)</sup> ABB additional extension to ambient surrounding temperature, outside the cabinet, -30 °C...55 °C (-22 °F...131 °F). See also the instructions for ambient temperature derating.

<sup>3)</sup> L denotes service life >15 years.

### Disclaimer

The customer shall ensure that the environmental conditions inside the wind turbine is maintained in order to fulfill the environmental classifications and/or corrosion class, as herein stated. If the operational condition is out of any environmental classifications and/or corrosion class, the expected lifetime of the converter may be risked and the ABB converter warranty is terminated. If the customer is unsure about the environmental conditions and/or corrosion class inside the wind turbine, the customer is responsible for contacting ABB before the converter installation, and get an approval from ABB to use the converter in such an environmental condition and/or corrosive class.



## Ambient conditions

Environmental limits for the converter are given below. The converter must be used in a heated, indoor controlled environment.

	<b>Operation</b> installed for stationary use	<b>Storage</b> in protective package	<b>Transportation</b> in protective package
<b>Installation site altitude</b>	0 ... 2000 m (0 ... 6562 ft) above sea level. Above 1000 m (3281 ft), see the derating instructions.	-	-
<b>Installation site altitude</b>	0 ... 1000 m (0 ... 3281 ft) above sea level. Above 1000 m (3281 ft), see the derating instructions.	-	-
<b>Air temperature</b>	-30 ... +45 °C (-22 ... +113 °F) (with heating procedure below +15 °C before start-up) Freezing of coolant is not allowed. Above +45 °C (+113 °F), see the derating instructions.	-40 ... +70 °C (-40 ... +158 °F)	-40 ... +70 °C (-40 ... +158 °F)
<b>Relative humidity</b>	0 ... 95%	0 ... 95%	0 ... 95%
	No condensation allowed. Maximum allowed relative humidity is 60% in the presence of corrosive gases.		
<b>Contamination levels</b> (IEC 60721-3-3, IEC 60721-3-2, IEC 60721-3-1)	No conductive dust allowed.		
	<b>Boards with coating:</b> Chemical gases: Class 3C2 Solid particles: Class 3S2	<b>Boards with coating:</b> Chemical gases: Class 1C2 Solid particles: Class 1S3	<b>Boards with coating:</b> Chemical gases: Class 2C2 Solid particles: Class 2S2
<b>Atmospheric pressure</b>	70 ... 106 kPa 0.7 ... 1.05 atmospheres	70 ... 106 kPa 0.7 ... 1.05 atmospheres	60 ... 106 kPa 0.6 ... 1.05 atmospheres
<b>Vibration</b> (IEC 60068-2-6)	10 ... 58 Hz, max. 0.075 mm displacement amplitude 58...150 Hz 10 m/s <sup>2</sup>	10 ... 58 Hz, max. 0.075 mm displacement amplitude 58...150 Hz 10 m/s <sup>2</sup>	Max. 3.5 mm (0.14 in) (2 ... 9 Hz), max. 15 m/s <sup>2</sup> (49 ft/s <sup>2</sup> ) (9 ... 200 Hz) sinusoidal
<b>Shock</b> (IEC 60068-2-27)	Not allowed	Max. 100 m/s <sup>2</sup> (330 ft/s <sup>2</sup> ), 11 ms	Max. 100 m/s <sup>2</sup> (330 ft/s <sup>2</sup> ), 11 ms
<b>Free fall</b>	Not allowed	100 mm (4 in)	100 mm (4 in)

## Materials

Cabinet	Hot-dip zinc-coated (thickness approx. 20 µm) steel sheet (thickness 1.5 mm) with polyester thermosetting powder coating (thickness approx. 80 µm) on visible surfaces. Color: RAL 7035 (light beige, semi-gloss). Color of the side panels: RAL 9017 (black, semi-gloss)
Busbars	Painted or tin- or silver-plated copper or aluminum
Internal cooling circuit piping	Aluminum, acid-fast stainless steel, PA pipes
Air filters (door)	IP54 Cassette filter: 292 × 288 × 47 mm (ABB code: 64719998) IP42 filter (Air-Tex G-150): 5158 × 520 × 12 mm (ABB code: 64665324)
Fire safety of materials (IEC 60332-1)	Insulating materials and non-metallic items: Mostly self-extinctive
Packaging	Frame: Wood or plywood. Plastic wrapping: PE-LD. Bands: PP or steel.
Disposal	The main parts of the converter can be recycled to preserve natural resources and energy. Product parts and materials should be dismantled and separated. Generally all metals, such as steel, aluminum, copper and its alloys, and precious metals can be recycled as material. Plastics, rubber, cardboard and other packaging material can be used in energy recovery. Printed circuit boards and large electrolytic capacitors need selective treatment according to IEC 62635 guidelines. To aid recycling, plastic parts are marked with an appropriate identification code. Contact your local ABB distributor for further information on environmental aspects and recycling instructions for professional recyclers. End of life treatment must follow international and local regulations.

## Auxiliary circuit current consumption

Auxiliary circuit current consumption varies depending on the size of the converter and selected options. For detailed information, contact your local ABB representative.

## Applicable standards

	The converter complies with the standards below. The compliance with the European Low Voltage Directive is verified according to standards EN 61800-5-1.
•EN 60204-1:2006 + A1:2009 + AC:2010	Safety of machinery. Electrical equipment of machines. Part 1: General requirements. Provisions for compliance: The final assembler of the machine is responsible for installing - an emergency-stop device.
•EN 60529:1991	Degrees of protection provided by enclosures (IP code)
•EN/IEC 61439:2011	Low-voltage switchgear and controlgear assemblies
•EN/IEC 60146	Semiconductor converters - General requirements and line commutated converters
•EN/IEC 50178	Electronic equipment for use in power installations
•IEC 60664-1:2007	Insulation coordination for equipment within low-voltage systems. Part 1: Principles, requirements and tests.
•IEC 61400-1:2005	Wind turbines. Part 1: Design requirements
•IEC 61800-3:2017	Adjustable speed electrical power drive systems. Part 3: EMC requirements and specific test methods
•EN 61800-5-1:2007	Adjustable speed electrical power drive systems. Part 5-1: Safety requirements – electrical, thermal and energy.
•BS7671	Requirements for electrical installations
•UL 61800-5-1	Adjustable Speed Electrical Power Drive Systems - Part 5-1: Safety Requirements - Electrical, Thermal and Energy. See section <a href="#">ETL marking (page 105)</a> .

## CE marking

A CE mark is attached to the converter to verify that the converter follows the provisions of the European Low Voltage Directive 2014/35/EU (previously 2006/95/EC) and EMC Directive 2014/30/EU (previously 2004/108/EC).

### ■ Compliance with the European Low Voltage Directive

The compliance with the European Low Voltage Directive has been verified according to standard EN 61800-5-1.

### ■ Compliance with the European EMC Directive

See section [Compliance with EN 61800-3:2004/A1:2012 \(page 104\)](#).

## Compliance with the European Machinery Directive

**Note:** In standard texts, the term 'drive' stands for 'converter' in case of wind turbine applications.

The drive is an electronic product which is covered by the European Low Voltage Directive. The drive is equipped with a main circuit breaker which can be used in safety functions for machinery. These safety functions are in the scope of the Machinery Directive as safety components, and appropriate harmonized standards (EN ISO 13849 or EN 62061) shall be applied.

## Regulatory Compliance Mark (RCM)

RCM marking is pending. Applies as Compliance with EN 61800-3:2004.

---

## EAC (Eurasian Conformity) marking

<b>EAC</b>	<p>EAC (Eurasian Conformity) mark</p> <p>Product complies with the technical regulations of the Eurasian Customs Union. EAC mark is required in Russia, Belarus and Kazakhstan.</p>
------------	---

## Compliance with EN 61800-3:2004/A1:2012

### ■ Definitions

EMC stands for Electromagnetic Compatibility. It is the ability of electrical/electronic equipment to operate without problems within an electromagnetic environment. Likewise, the equipment must not disturb or interfere with any other product or system within its locality.

First environment includes establishments connected to a low-voltage network which supplies buildings used for domestic purposes.

Second environment includes establishments connected to a network not supplying domestic premises.

Drive of category C4: drive of rated voltage equal to or above 1000 V, or rated current equal to or above 400 A, or intended for use in complex systems in the second environment.

### ■ Category C4

The requirements of the standard can be met as follows:

1. It is ensured that no excessive emission is propagated to neighbouring low-voltage networks. In some cases, the natural suppression in transformers and cables is sufficient. If in doubt, the supply transformer with static screening between the primary and secondary windings can be used.

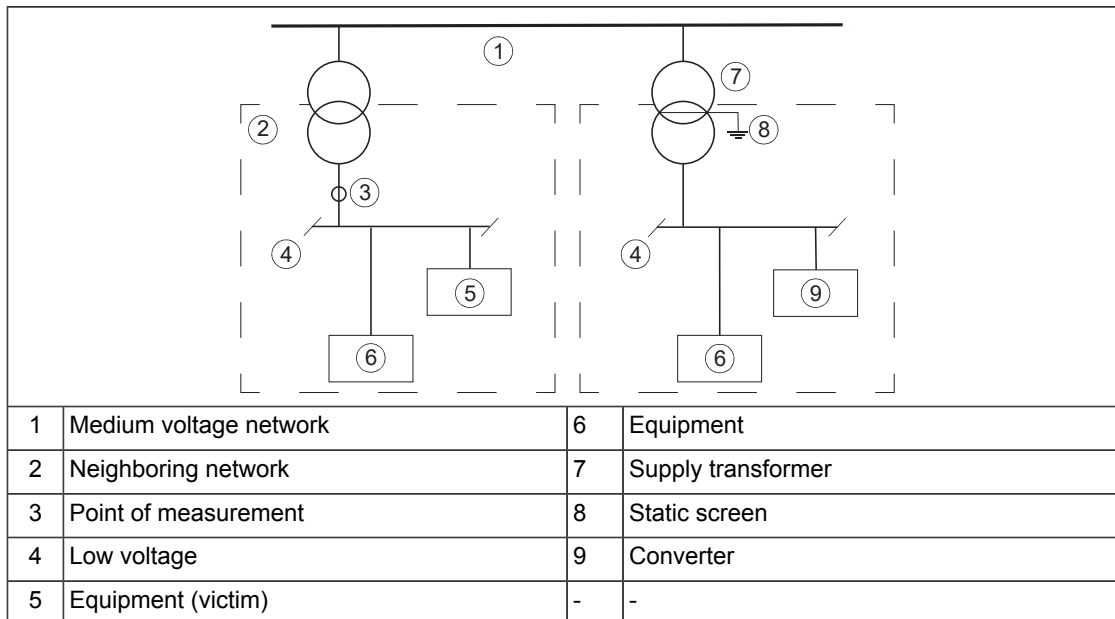

2. An EMC plan for preventing disturbances is drawn up for the installation. A template is available from the local ABB representative.
3. The generator and control cables are selected as specified in the hardware manual.
4. The converter is installed according to the instructions given in the hardware manual.

**WARNING!**

A drive of category C4 is not intended to be used on a low-voltage public network which supplies domestic premises. Radio frequency interference is expected if the converter is used on such a network.

## ETL marking

ETL marking is pending.

The converter provides overload protection in accordance with the National Electrical Code (US) and Canadian Electrical Code (Canada). See the firmware manual for setting. Default setting is off; the setting must be activated at start-up.

The converters are to be used in a heated indoor controlled environment. See the ambient conditions for specific limits.

## WEEE mark

	<p>WEEE mark</p> <p>At the end of life the product should enter the recycling system at an appropriate collection point and not placed in the normal waste stream.</p>
--	--

## GL2010

Available on request.

## Disclaimers

### ■ Generic disclaimer

The manufacturer shall have no obligation with respect to any product which (i) has been improperly repaired or altered; (ii) has been subjected to misuse, negligence or accident; (iii) has been used in a manner contrary to the manufacturer's instructions; or (iv) has failed as a result of ordinary wear and tear.

### ■ Cybersecurity disclaimer

This product can be connected to and to communicate information and data via a network interface. The HTTP protocol, which is used between the commissioning tool (Drive Composer) and the product, is an unsecured protocol. For independent and continuous operation of product such connection via network to commissioning tool is not necessary. However it is Customer's sole responsibility to provide and continuously ensure a secure connection between the product and Customer network or any other network (as the case may be). Customer shall establish and maintain any appropriate measures (such as but not limited to the installation of firewalls, prevention of physical access, application of authentication measures, encryption of data, installation of anti-virus programs, etc) to protect the product, the network, its system and the interface against any kind of security breaches, unauthorized access, interference, intrusion, leakage and/or theft of data or information.

Notwithstanding any other provision to the contrary and regardless whether the contract is terminated or not, ABB and its affiliates are under no circumstances not liable for damages

*106 Technical data*

and/or losses related to such security breaches, any unauthorized access, interference, intrusion, leakage and/or theft of data or information.

# 10

## BCU-x2 control unit

---

### Contents of this chapter

This chapter describes the layout and connections of the BCU-x2 control unit and contains the specifications of the inputs and outputs of the control unit.

For the actual connections of the control units used in the ACS880-87CC converter, see the circuit diagrams delivered with the converter.

### General

#### ■ BCU control unit

The BCU control unit consists of a BCON control board (and a BIOC I/O and power supply board) built in a metal housing. The BCU is mounted separately from the converter module(s), and connected to the module(s) by fiber optic cables. In this manual, the name “BCU-x2” represents the control unit types BCU-12/-22.

---

# Layout and connections

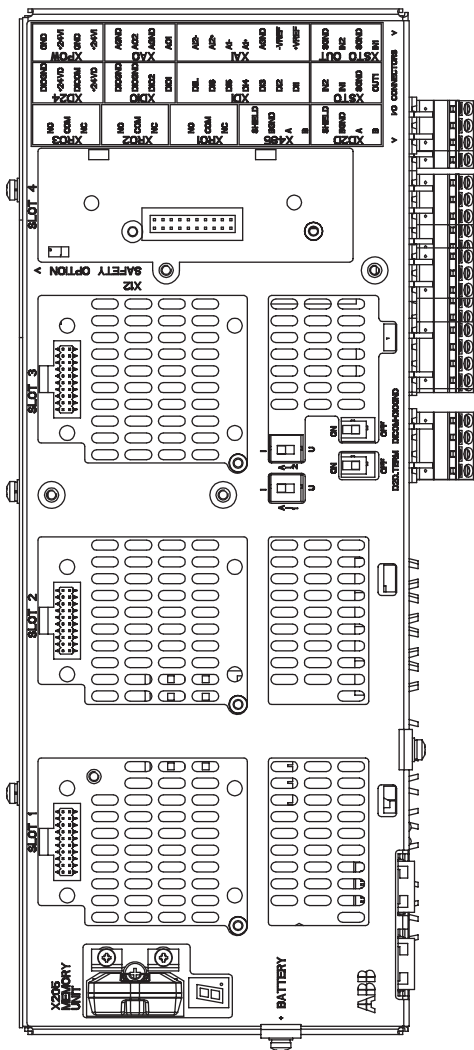

	Description
I/O	I/O terminals
SLOT 1	I/O extension, encoder interface or fieldbus adapter module connection. (This is the sole location for an FDPI-02 diagnostics and panel interface.)
SLOT 2	I/O extension, encoder interface or fieldbus adapter module connection
SLOT 3	I/O extension, encoder interface or fieldbus adapter module connection
SLOT 4	RDCO-0x DDCS communication option module connection
X205	Memory unit connection
BATTERY	Holder for real-time clock battery (BR2032)
AI1	Mode selector for analog input AI1 (I = current, U = voltage)
AI2	Mode selector for analog input AI2 (I = current, U = voltage)
D2D TERM	Termination switch for drive-to-drive link (D2D)
DICOM=DIOGND	Ground selection. Determines whether DICOM is separated from DIOGND (ie. the common reference for the digital inputs floats).
<b>7-segment display</b>	
Multicharacter indications are displayed as repeated sequences of characters	
	("U" is indicated briefly before "o".) Control program running
	Control program startup in progress
	(Flashing) Firmware cannot be started. Memory unit missing or corrupted
	Firmware download from PC to control unit in progress
	At power-up, the display may show short indications of eg. "1", "2", "b" or "U". These are normal indications immediately after power-up. If the display ends up showing any other value than those described, it indicates a hardware failure.



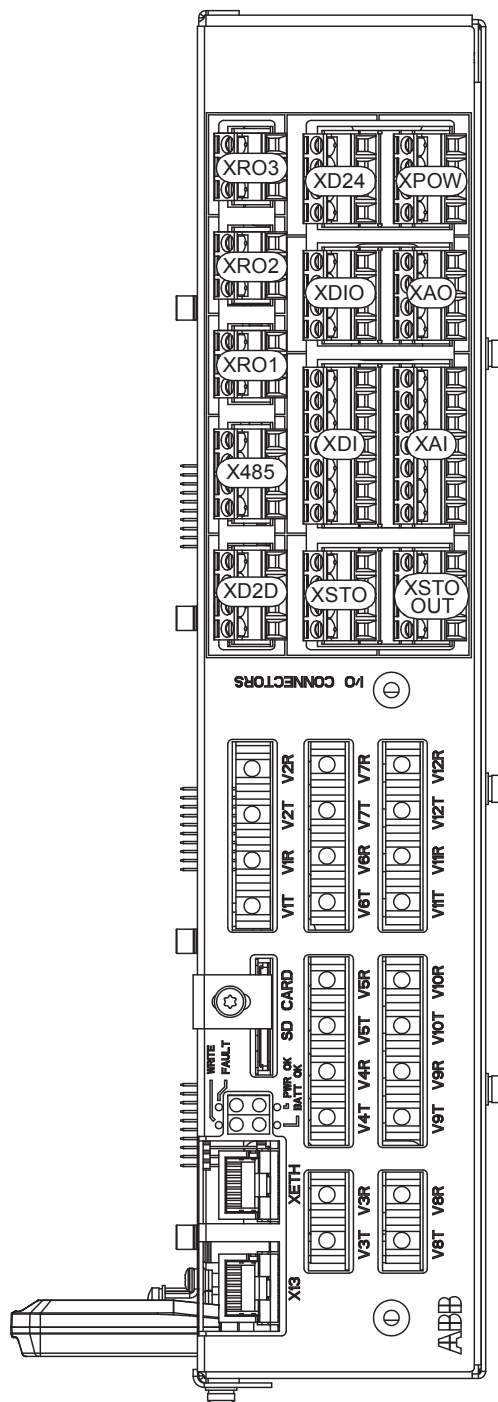

	Description
XAI	Analog inputs
XAO	Analog outputs
XDI	Digital inputs, Digital input interlock (DIIL)
XDIO	Digital input/outputs
XD2D	Drive-to-drive link
XD24	+24 V output (for digital inputs)
XETH	Ethernet port
XPOW	External power input
XRO1	Relay output RO1
XRO2	Relay output RO2
XRO3	Relay output RO3
XSTO	Not in use in wind turbine converters.
XSTO OUT	Not in use in wind turbine converters.
X12	Not in use in wind turbine converters.
X13	Control panel connection
X485	Not in use
V1T/V1R, V2T/V2R	Fiber optic connection to converter modules 1 and 2 (VxT = transmitter, VxR = receiver)
V3T/V3R ... V7T/V7R	Fiber optic connection to converter modules 3...7 (BCU-12/22 only) (VxT = transmitter, VxR = receiver)
V8T/V8R ... V12T/V12R	Fiber optic connection to converter modules 8...12 (BCU-22 only) (VxT = transmitter, VxR = receiver)
SD CARD	Data logger memory card for converter module communication
BATT OK	Real-time clock battery voltage is higher than 2.8 V. If the LED is off when the control unit is powered, replace the battery.
FAULT	The control program has generated a fault. See the firmware manual.
PWR OK	Internal voltage supply is OK.
WRITE	Writing to memory card in progress. Do not remove the memory card.

## Connector data

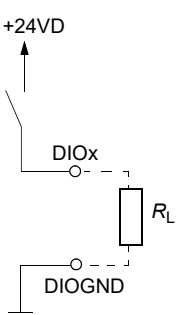
Power supply (XPOW)	<p>Connector pitch 5 mm, wire size 2.5 mm<sup>2</sup>                  24 V (±10%) DC, 2 A                  External power input.                  Two supplies can be connected to BCU for redundancy.</p>
Relay outputs RO1...RO3 (XRO1...XRO3)	<p>Connector pitch 5 mm, wire size 2.5 mm<sup>2</sup>                  250 V AC / 30 V DC, 2 A                  Protected by varistors</p>
+24 V output (XD24:2 and XD24:4)	<p>Connector pitch 5 mm, wire size 2.5 mm<sup>2</sup>                  Total load capacity of these outputs is 4.8 W (200 mA / 24 V) minus the power taken by DIO1 and DIO2.</p>
Digital inputs DI1...DI6 (XDI:1...XDI:6)	<p>Connector pitch 5 mm, wire size 2.5 mm<sup>2</sup>                  24 V logic levels: "0" &lt; 5 V, "1" &gt; 15 V  <math>R_{in}</math>: 2.0 kohm                  Input type: NPN/PNP (DI1...DI5), NPN (DI6)                  Hardware filtering: 0.04 ms, digital filtering up to 8 ms                  DI6 (XDI:6) can alternatively be used as an input for a PTC sensor.                  "0" &gt; 4 kohm, "1" &lt; 1.5 kohm.  <math>I_{max}</math>: 15 mA (DI1...DI5), 5 mA (DI6)</p>
Start interlock input DIIL (XDI:7)	<p>Connector pitch 5 mm, wire size 2.5 mm<sup>2</sup>                  24 V logic levels: "0" &lt; 5 V, "1" &gt; 15 V  <math>R_{in}</math>: 2.0 kohm                  Input type: NPN/PNP                  Hardware filtering: 0.04 ms, digital filtering up to 8 ms</p>
Digital inputs/outputs DIO1 and DIO2 (XDIO:1 and XDIO:2) Input/output mode selection by parameters. DIO1 can be configured as a frequency input (0...16 kHz with hardware filtering of 4 microseconds) for 24 V level square wave signal (sinusoidal or other wave form cannot be used). DIO2 can be configured as a 24 V level square wave frequency output. See the firmware manual, parameter group 11/111.	<p>Connector pitch 5 mm, wire size 2.5 mm<sup>2</sup>  <u>As inputs:</u> 24 V logic levels: "0" &lt; 5 V, "1" &gt; 15 V. <math>R_{in}</math>: 2.0 kohm. Filtering: 1 ms.  <u>As outputs:</u> Total output current from +24VD is limited to 200 mA</p> 
Reference voltage for analog inputs +VREF and -VREF (XAI:1 and XAI:2)	<p>Connector pitch 5 mm, wire size 2.5 mm<sup>2</sup>                  10 V ±1% and -10 V ±1%, <math>R_{load}</math> 1...10 kohm                  Maximum output current: 10 mA</p>
Analog inputs AI1 and AI2 (XAI:4 ... XAI:7). Current/voltage input mode selection by switches	<p>Connector pitch 5 mm, wire size 2.5 mm<sup>2</sup>                  Current input: -20...20 mA, <math>R_{in}</math> = 100 ohm                  Voltage input: -10...10 V, <math>R_{in}</math> &gt; 200 kohm                  Differential inputs, common mode range ±30 V                  Sampling interval per channel: 0.25 ms                  Hardware filtering: 0.25 ms, adjustable digital filtering up to 8 ms                  Resolution: 11 bit + sign bit                  Inaccuracy: 1% of full scale range</p>

Analog outputs AO1 and AO2 (XAO)	Connector pitch 5 mm, wire size 2.5 mm <sup>2</sup> 0...20 mA, $R_{load} < 500$ ohm Frequency range: 0...500 Hz Resolution: 11 bit + sign bit Inaccuracy: 2% of full scale range
XD2D connector	Connector pitch 5 mm, wire size 2.5 mm <sup>2</sup> Physical layer: RS-485 Transmission rate: 8 Mbit/s Cable type: Shielded twisted-pair cable with a twisted pair for data and a wire or another pair for signal ground (nominal impedance 100 ... 165 ohm, for example Belden 9842) Termination by switch
RS-485 connection (X485)	Connector pitch 5 mm, wire size 2.5 mm <sup>2</sup> Physical layer: RS-485
Safe torque off connection (XSTO)	Connector pitch 5 mm, wire size 2.5 mm <sup>2</sup> Input voltage range: -3...30 V DC Logic levels: "0" < 5 V, "1" > 17 V. <b>Note:</b> For the converter to start, both connections must be "1". EMC (immunity) according to IEC 61326-3-1
Safe torque off output (XSTO OUT)	Connector pitch 5 mm, wire size 2.5 mm <sup>2</sup>
Control panel connection (X13)	Connector: RJ-45 Cable length < 3 m
Ethernet connection (XETH)	Connector: RJ-45
SDHC memory card slot (SD CARD)	Memory card type: SDHC Maximum memory size: 4 GB
The terminals of the control unit fulfill the Protective Extra Low Voltage (PELV) requirements. The PELV requirements of a relay output are not fulfilled if a voltage higher than 48 V is connected to the relay output.	



# 11

## BCU-x5 control unit

---

### Contents of this chapter

This chapter describes the layout and connections of the BCU-x5 control unit and contains the specifications of the inputs and outputs of the control unit.

For the actual connections of the control units used in the ACS880-87CC converter, see the circuit diagrams delivered with the converter.

### General

#### ■ BCU control unit

The BCU control unit consists of a BCON control board (and a BIOC I/O and power supply board) built in a metal housing. The BCU is mounted separately from the converter module(s), and connected to the module(s) by fiber optic cables. In this manual, the name “BCU-x5” represents the control unit types BCU-15/-25.

---

# Layout and connections

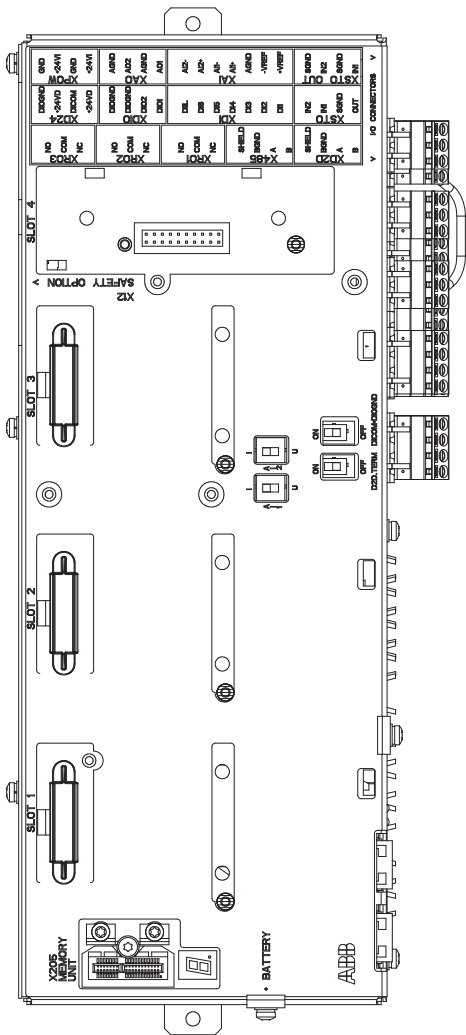

	Description
I/O	I/O terminals
SLOT 1	I/O extension, encoder interface or fieldbus adapter module connection. (This is the sole location for an FDPI-02 diagnostics and panel interface.)
SLOT 2	I/O extension, encoder interface or fieldbus adapter module connection
SLOT 3	I/O extension, encoder interface or fieldbus adapter module connection
SLOT 4	RDCO-0x DDCS communication option module connection
X205	Memory unit connection
BATTERY	Holder for real-time clock battery (BR2032)
AI1	Mode selector for analog input AI1 (I = current, U = voltage)
AI2	Mode selector for analog input AI2 (I = current, U = voltage)
D2D.TERM	Termination switch for drive-to-drive link (D2D)
DICOM=DIOGND	Ground selection. Determines whether DICOM is separated from DIOGND (ie. the common reference for the digital inputs floats).
<b>7-segment display</b>	
Multicharacter indications are displayed as repeated sequences of characters	
	("U" is indicated briefly before "o".) Control program running
	Control program startup in progress
	(Flashing) Firmware cannot be started. Memory unit missing or corrupted
	Firmware download from PC to control unit in progress
	At power-up, the display may show short indications of eg. "1", "2", "b" or "U". These are normal indications immediately after power-up. If the display ends up showing any other value than those described, it indicates a hardware failure.

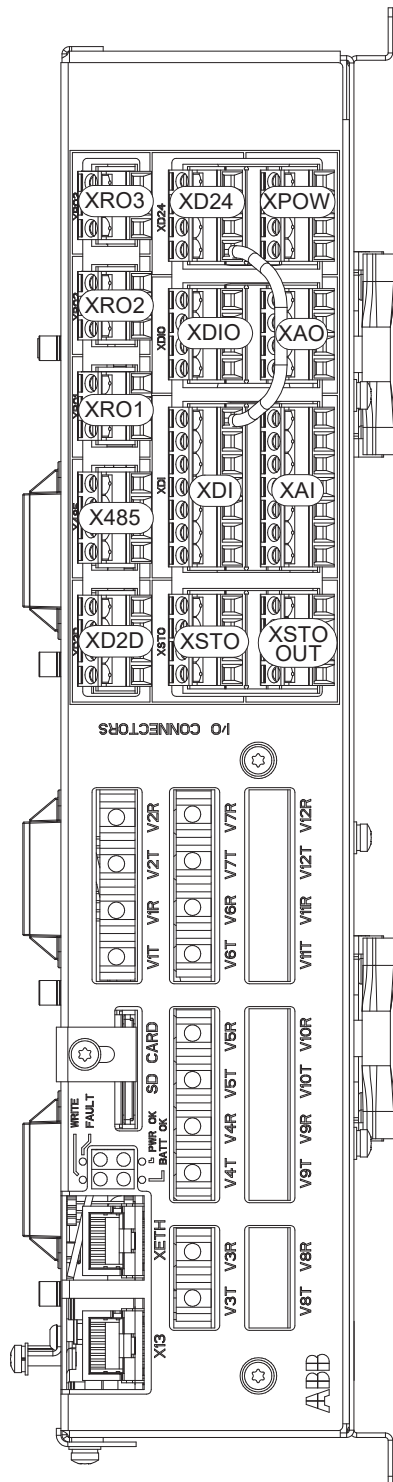

	Description
XAI	Analog inputs
XAO	Analog outputs
XDI	Digital inputs, Digital input interlock (DIIL)
XDIO	Digital input/outputs
XD2D	Drive-to-drive link
XD24	+24 V output (for digital inputs)
XETH	Ethernet port
XPOW	External power input
XRO1	Relay output RO1
XRO2	Relay output RO2
XRO3	Relay output RO3
XSTO	Not in use in wind turbine converters.
XSTO OUT	Not in use in wind turbine converters.
X12	Not in use in wind turbine converters.
X13	Control panel connection
X485	Not in use
V1T/V1R, V2T/V2R	Fiber optic connection to converter modules 1 and 2 (VxT = transmitter, VxR = receiver)
V3T/V3R ... V7T/V7R	Fiber optic connection to converter modules 3...7 (BCU-15/-25 only) (VxT = transmitter, VxR = receiver)
V8T/V8R ... V12T/V12R	Fiber optic connection to converter modules 8...12 (BCU-25 only) (VxT = transmitter, VxR = receiver)
SD CARD	Data logger memory card for converter module communication
BATT OK	Real-time clock battery voltage is higher than 2.8 V. If the LED is off when the control unit is powered, replace the battery.
FAULT	The control program has generated a fault. See the firmware manual.
PWR OK	Internal voltage supply is OK.
WRITE	Writing to memory card in progress. Do not remove the memory card.

116 BCU-x5 control unit

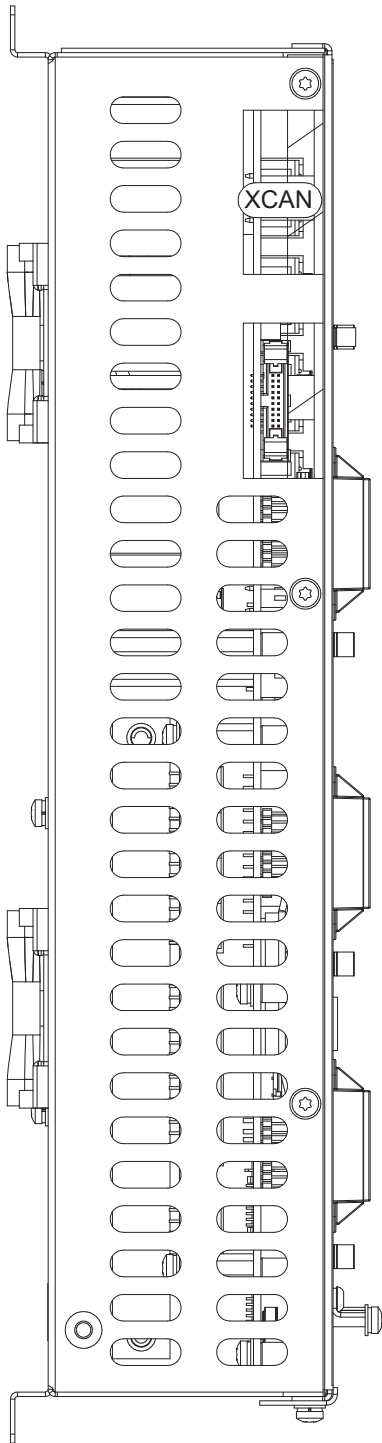

	Description
XCAN	CAN bus connection

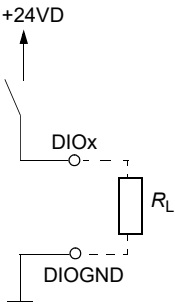

## Connector data

Power supply (XPOW)	Connector pitch 5 mm, wire size 2.5 mm <sup>2</sup> 24 V ( $\pm 10\%$ ) DC, 2 A External power input. Two supplies can be connected to BCU for redundancy.
Relay outputs RO1...RO3 (XRO1...XRO3)	Connector pitch 5 mm, wire size 2.5 mm <sup>2</sup> 250 V AC / 30 V DC, 2 A Protected by varistors
+24 V output (XD24:2 and XD24:4)	Connector pitch 5 mm, wire size 2.5 mm <sup>2</sup> Total load capacity of these outputs is 4.8 W (200 mA / 24 V) minus the power taken by DIO1 and DIO2.
Digital inputs DI1...DI6 (XDI:1...XDI:6)	Connector pitch 5 mm, wire size 2.5 mm <sup>2</sup> 24 V logic levels: "0" < 5 V, "1" > 15 V $R_{in}$ : 2.0 kohm Input type: NPN/PNP (DI1...DI5), NPN (DI6) Hardware filtering: 0.04 ms, digital filtering up to 8 ms DI6 (XDI:6) can alternatively be used as an input for a PTC sensor. "0" > 4 kohm, "1" < 1.5 kohm. $I_{max}$ : 15 mA (DI1...DI5), 5 mA (DI6)
Start interlock input DIIL (XDI:7)	Connector pitch 5 mm, wire size 2.5 mm <sup>2</sup> 24 V logic levels: "0" < 5 V, "1" > 15 V $R_{in}$ : 2.0 kohm Input type: NPN/PNP Hardware filtering: 0.04 ms, digital filtering up to 8 ms
Digital inputs/outputs DIO1 and DIO2 (XDIO:1 and XDIO:2) Input/output mode selection by parameters. DIO1 can be configured as a frequency input (0...16 kHz with hardware filtering of 4 microseconds) for 24 V level square wave signal (sinusoidal or other wave form cannot be used). DIO2 can be configured as a 24 V level square wave frequency output. See the firmware manual, parameter group 11/111.	Connector pitch 5 mm, wire size 2.5 mm <sup>2</sup> <u>As inputs:</u> 24 V logic levels: "0" < 5 V, "1" > 15 V. $R_{in}$ : 2.0 kohm. Filtering: 1 ms. <u>As outputs:</u> Total output current from +24VD is limited to 200 mA 
Reference voltage for analog inputs +VREF and -VREF (XAI:1 and XAI:2)	Connector pitch 5 mm, wire size 2.5 mm <sup>2</sup> 10 V $\pm 1\%$ and -10 V $\pm 1\%$ , $R_{load}$ 1...10 kohm Maximum output current: 10 mA
Analog inputs AI1 and AI2 (XAI:4 ... XAI:7). Current/voltage input mode selection by switches	Connector pitch 5 mm, wire size 2.5 mm <sup>2</sup> Current input: -20...20 mA, $R_{in}$ = 100 ohm Voltage input: -10...10 V, $R_{in}$ > 200 kohm Differential inputs, common mode range $\pm 30$ V Sampling interval per channel: 0.25 ms Hardware filtering: 0.25 ms, adjustable digital filtering up to 8 ms Resolution: 11 bit + sign bit Inaccuracy: 1% of full scale range

118 BCU-x5 control unit

Analog outputs AO1 and AO2 (XAO)	Connector pitch 5 mm, wire size 2.5 mm <sup>2</sup> 0...20 mA, $R_{load} < 500$ ohm Frequency range: 0...500 Hz Resolution: 11 bit + sign bit Inaccuracy: 2% of full scale range
XD2D connector	Connector pitch 5 mm, wire size 2.5 mm <sup>2</sup> Physical layer: RS-485 Transmission rate: 8 Mbit/s Cable type: Shielded twisted-pair cable with a twisted pair for data and a wire or another pair for signal ground (nominal impedance 100 ... 165 ohm, for example Belden 9842) Termination by switch
RS-485 connection (X485)	Connector pitch 5 mm, wire size 2.5 mm <sup>2</sup> Physical layer: RS-485
Safe torque off connection (XSTO)	Connector pitch 5 mm, wire size 2.5 mm <sup>2</sup> Input voltage range: -3...30 V DC Logic levels: "0" < 5 V, "1" > 17 V. <b>Note:</b> For the converter to start, both connections must be "1". EMC (immunity) according to IEC 61326-3-1
Safe torque off output (XSTO OUT)	Connector pitch 5 mm, wire size 2.5 mm <sup>2</sup>
Control panel connection (X13)	Connector: RJ-45 Cable length < 3 m
Ethernet connection (XETH)	Connector: RJ-45
SDHC memory card slot (SD CARD)	Memory card type: SDHC Maximum memory size: 4 GB
CAN bus connection (XCAN)	Connector pitch 5 mm, wire size 2.5 mm <sup>2</sup> Physical layer: CAN Termination by jumpering XCAN:1 and XCAN:2 together
The terminals of the control unit fulfill the Protective Extra Low Voltage (PELV) requirements. The PELV requirements of a relay output are not fulfilled if a voltage higher than 48 V is connected to the relay output.	

# 12

## Dimension drawings

---

### Contents of this chapter

This chapter contains dimension drawings of the wind turbine converter. See also the dimension drawings delivered with the converter.

---





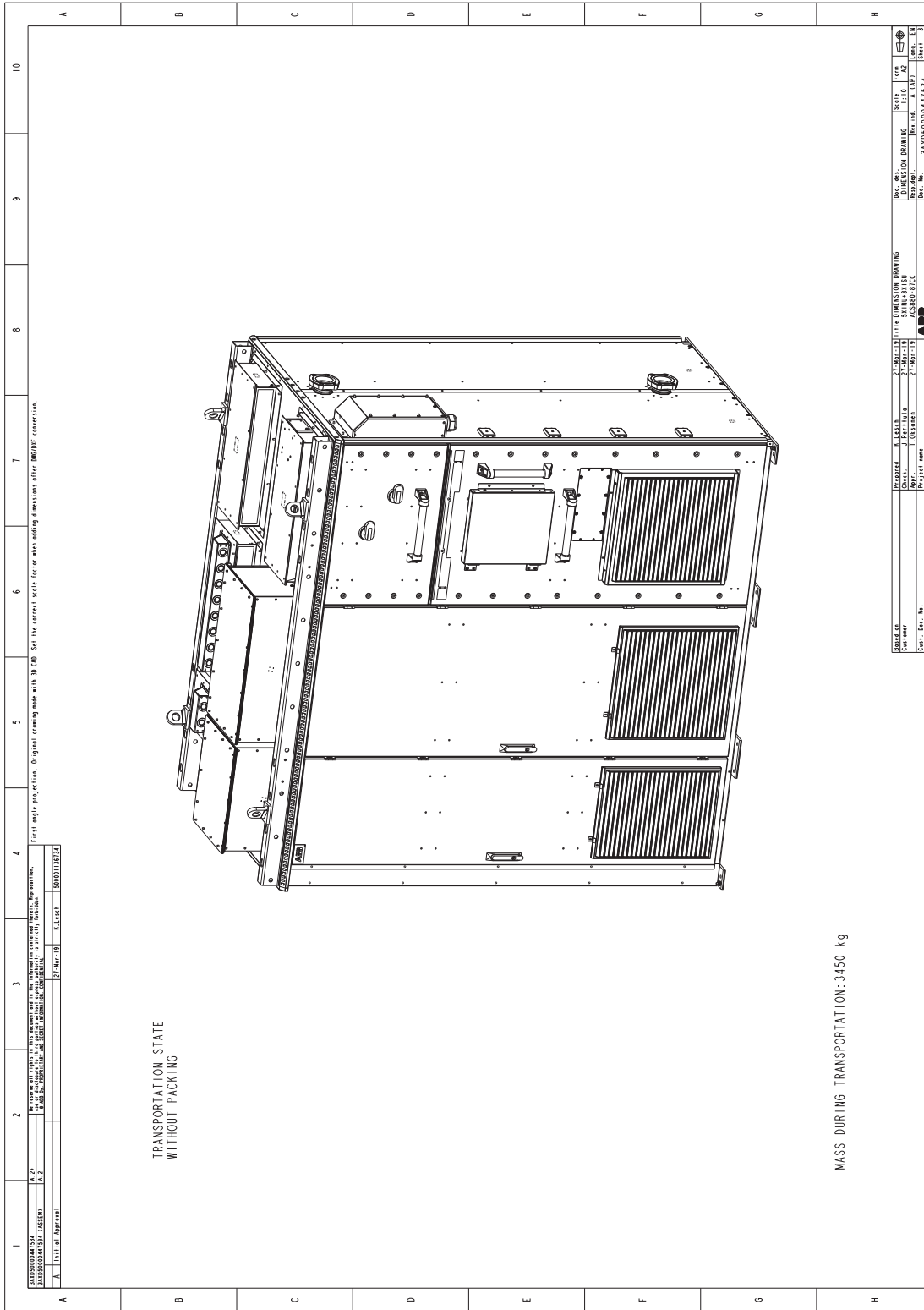

# 13

## Cooling and heating

---

### Contents of this chapter

This chapter deals with the internal cooling circuit.

### Hardware description

- **General**

The internal cooling circuit covers the heat-generating electrical components and transfers the heat to the external cooling circuit that is usually part of a larger external cooling system.

- **Diagram of the internal cooling and heating circuit**

The following diagram shows how coolant circulates in the grid-side converter, LCL filter, main breaker and generator-side converter cubicles of the wind turbine converter.

The converter cabinet is combined-cooled: main components (such as IGBTs, module du/dt filter (choke, resistors), and chokes of the LCL filter) are liquid-cooled. Control electronics, capacitors of the LCL filter, and main circuit breaker are air-cooled. There are air inlets on the cabinet doors, and air outlets on the cabinet roof and doors.

---

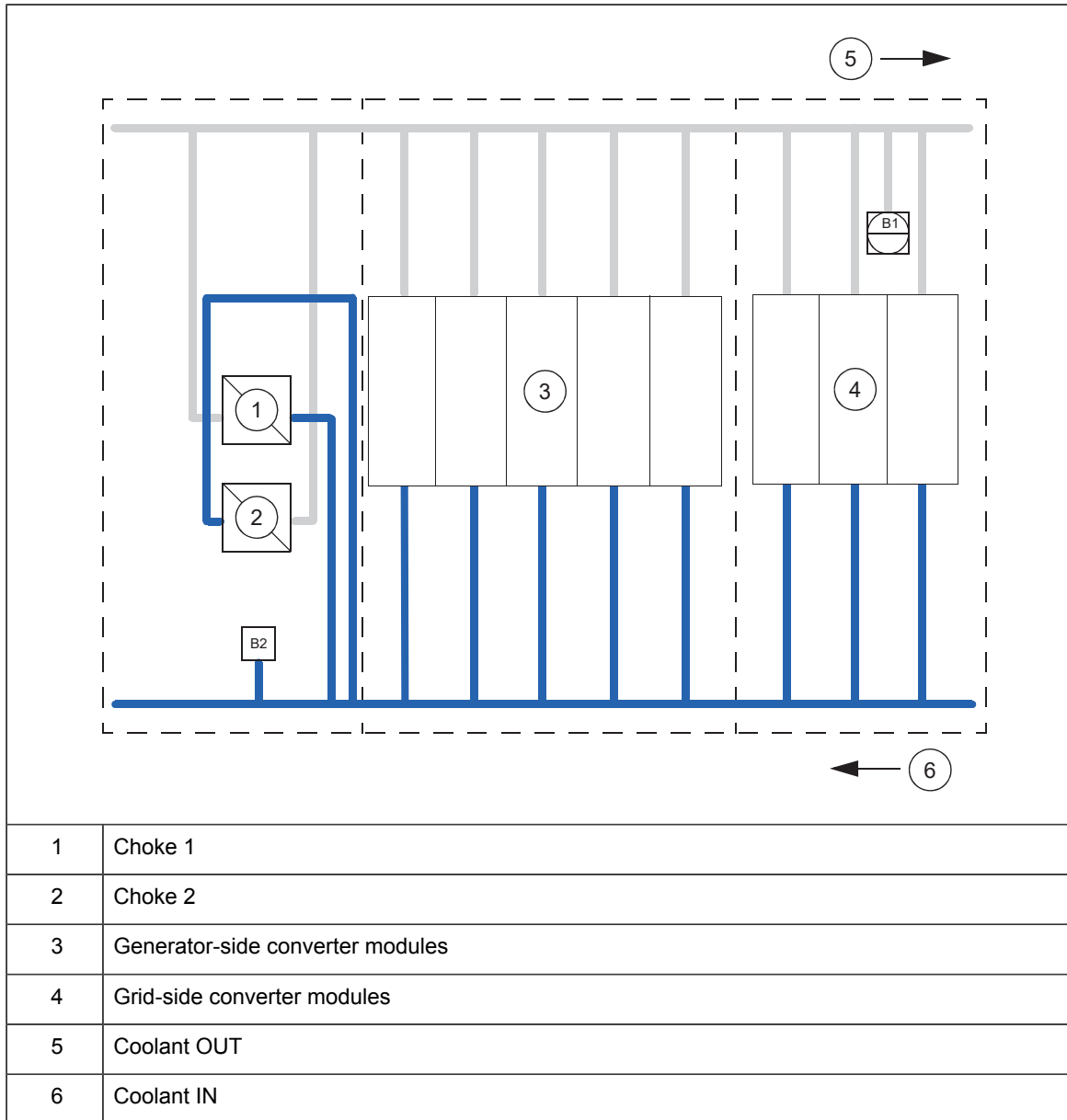



## Planning the cooling system

### ■ Connection to a cooling unit

#### General requirements

Equip the system with an expansion tank to damp pressure rise due to volume changes when the temperature varies. Keep the pressure within the limits specified in section [Specifications \(page 129\)](#). Install a pressure regulator to ensure that the maximum permissible operating pressure is not exceeded.

Install a bleeding valve at the highest point of the cooling circuit. Bleeding valve is not included in the ABB converter delivery as standard.

The materials used in the cooling system are listed in section [Specifications \(page 129\)](#).

#### Coolant temperature control

The temperature of the coolant in the internal cooling circuit must be kept within the limits specified in section [Specifications \(page 129\)](#). Note that the minimum temperature depends on ambient temperature and relative humidity.

The following diagram shows an example of coolant temperature control using the three-way valve in the external cooling circuit. Part of the infeed coolant flow is directed into the return pipe through a three-way valve without letting it circulate in the internal cooling circuit if the coolant in the internal circuit is too cold.

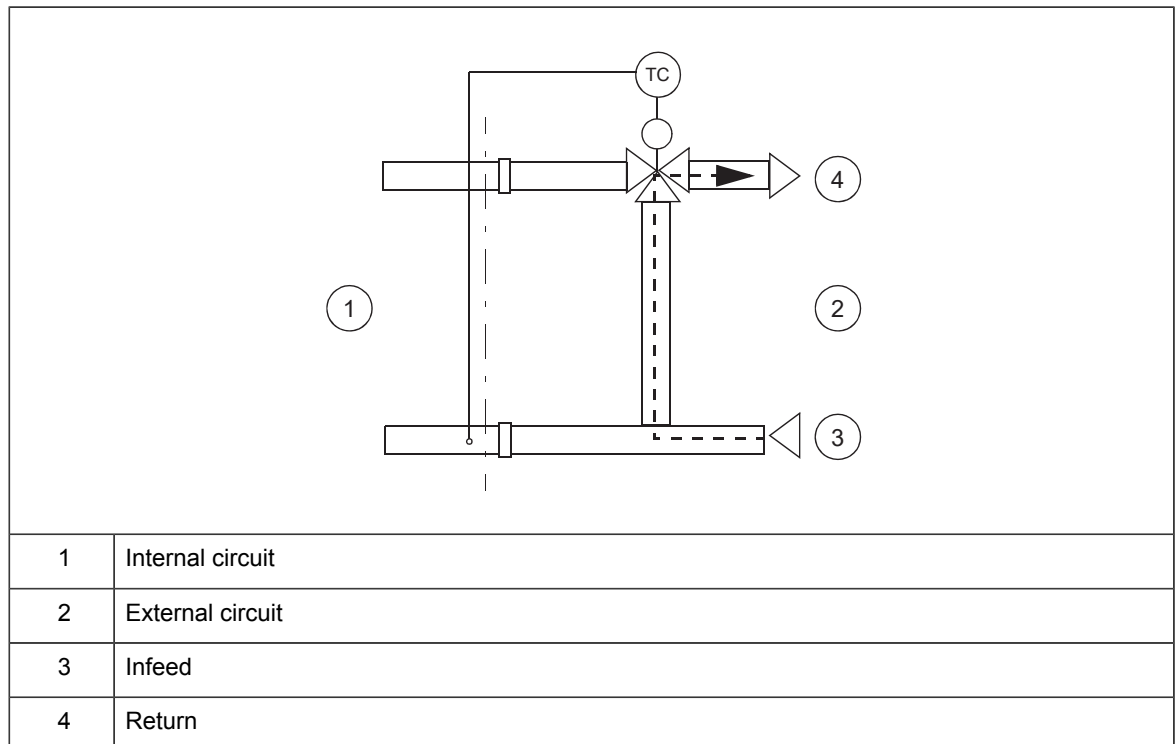

## Mechanical installation

### ■ Connecting the internal cooling circuit to a customer cooling unit

The converter delivery does not include the liquid cooling unit that is to be connected to the converter cabinet.

#### Connecting the liquid pipes

**Note:** It is recommended to use closing valves in the pipe connections of the cooling circuit.

1. Ensure that there is sufficient space and free access to make proper cooling pipe connections between the liquid cooling unit and the converter. It is not allowed to use inflexible and fixed cooling pipe connections between two separate units (eg, liquid cooling unit and the converter connection). Always use a flexible connector that can reduce possible stress caused by eg, vibration.
2. Check visually that the converter liquid pipes are not damaged (threads and flange joint not damaged).
3. Connect the external cooling circuit directly to the coupling pipes on the side of the converter. Lay liquid piping with extreme care. Secure the pipes properly mechanically and check for leaks. See the technical data for the pipe materials.
4. Position the liquid pipe ends against each other.
5. Centre the connector onto the pipe ends.
6. Tighten the
  - threaded connector carefully and ensure that it is slid on the pipe ends. The use of appropriate sealant is recommended.
  - flange bolts to a minimum torque of 70 N·m (52 lbf·ft).
7. Make sure that the liquid pipes are securely connected.

## Filling up and bleeding the internal cooling circuit

Both the converter and coolant must be at room temperature before filling in the cooling circuit.



#### **WARNING!**

Obey these instructions. If you ignore them, injury or death, or damage to the equipment can occur.

- Use protective eyewear when working with the liquid cooling system.
  - Make sure that the maximum permissible operating pressure is not exceeded. When necessary control the pressure to appropriate level by draining excess coolant out of the system.
  - Do not drain propylene glycol into the sewer system.
  - Be careful when you bleed the cooling circuit. Air bubbles in the circuit may reduce or completely block coolant flow and cause overheating. Fill up and bleed the pumps in the cooling circuit carefully as they can get damaged when run dry. Obey the instructions of the external cooling unit.
- 
-

## ■ Converters with a customer cooling unit

### Notes:

- The bleed valves in the converter are used only to vent the air from the circuit so that it can be displaced by the coolant. The actual bleeding of the circuit must be done via an external bleed valve installed at the highest point of the cooling circuit. The most practical location for the valve is usually near or at the cooling unit.  
Bleeding and draining valves are not included in the standard delivery of the ABB converter.
  - Observe the instructions given by the manufacturer of the cooling unit. Pay special attention to filling up and bleeding the pumps properly as they may be damaged if operated when dry.
  - Draining propylene glycol into the sewer system is not allowed.
1. Open the bleed valve at the cooling unit.
  2. Lead the bleed hoses into buckets or other suitable containers. Extend the standard hoses if necessary.
  3. Fill the circuit with coolant. For coolant specification, see below.
  4. After the converter is filled up, coolant will start flowing from the bleed hose of the converter. Let some coolant flow out before closing the bleed valve.
  5. Let any air remaining in the system out through the bleed valve at the cooling unit.
  6. Close the bleed valve at the cooling unit.
  7. Continue to fill in coolant until a base pressure of 100...150 kPa is achieved.
  8. Open the bleed valve of the pump to allow any air out.
  9. Re-check the pressure and add coolant if necessary.
  10. Start the coolant pump. Let any air remaining in the system out through the bleed valve at the cooling unit.
  11. After one to two minutes, stop the pump or block the coolant flow with a valve.
  12. Re-check the pressure and add coolant if necessary.
  13. Repeat steps 10...12 a few times until all air is let out of the cooling circuit. Listen for a humming sound and/or feel the piping for vibration to find out if there is still air left in the circuit.

### Adjustments

- Set the base pressure to 100...150 kPa by draining coolant from the fill/drain coupling.
  - Control the coolant temperature so that it stays between the limits stated in section [Specifications \(page 129\)](#).
-

## Draining the internal cooling circuit

You can drain the internal cooling circuit through the cooling unit as follows:

**Note:** Draining coolant into the sewer system is not allowed.

---



### **WARNING!**

High-pressure hot coolant may be present in the internal cooling circuit. No work on the cooling circuit is allowed until the pressure is lowered down by stopping the pumps and draining coolant.

---

1. Lead the bleed hose into a bucket or other suitable container. Extend the standard hoses when necessary.
2. Open the bleed valve to let air displace the liquid.
3. If required, dry the piping with compressed oil-free air of less than 6 bar (600 kPa).
4. If the converter is to be stored in temperatures below 0 °C (32 °F),
  - dry the cooling circuit with air
  - fill the cooling circuit with a mixture of water and coolant according to section [Freeze protection and corrosion inhibition \(page 130\)](#)
  - drain the cooling circuit again.

## Cooling station control

See manufacturer's instructions, the circuit diagrams delivered with the converter, and the firmware manual.

---

## Specifications

### ■ Temperature limits

**Ambient temperature:** See the technical data.

**Minimum coolant inlet temperature:** Condensation or frost is not allowed. The minimum coolant temperature to avoid condensation (at an atmospheric pressure of 1 bar / 100 kPa) is shown below as a function of the relative humidity (RH) and the ambient temperature ( $T_{air}$ ). If coolant inlet temperature cannot be higher, the temperature values in the table below are absolute minimums.

To avoid all kind of condensation inside the converter: ABB highly recommends to maintain / heat up the cooling liquid +10 °C (+50 °F) above the ambient temperature (ie, air temperature outside the converter), within the limits that the cooling liquid minimum temperature is +5 °C (41 °F) and maximum temperature is +50 °C (122 °F). The table below shows the minimum coolant inlet temperatures.

$T_{air}$ (°C)	Min. $T_{coolant}$ (°C)				
	RH = 95%	RH = 80%	RH = 65%	RH = 50%	RH = 40%
5	4.3	1.9	-0.9	-4.5	-7.4
10	9.2	6.7	3.7	-0.1	-3.0
15	14.2	11.5	8.4	4.6	1.5
20	19.2	16.5	13.2	9.4	6.0
25	24.1	21.4	17.9	13.8	10.5
30	29.1	26.2	22.7	18.4	15.0
35	34.1	31.1	27.4	23.0	19.4
40	39.0	35.9	32.2	27.6	23.8
45	44.0	40.8	36.8	32.1	28.2
50	49.0	45.6	41.6	36.7	32.8
55	53.9	50.4	46.3	42.2	37.1
	Not allowed as standard but the coolant temperature must be 5 °C (41 °F) or above. Consult an ABB representative if operation below coolant temperature 5 °C (41 °F) is required.				
Example:	At an air temperature of 45 °C (113 °F) and relative humidity of 65% the coolant temperature may not be below +36.8 °C (98.2 °F).				

**Maximum coolant inlet temperature:** 50 °C (122 °F) without derating of the converter output capacity. Range above 50 °C (122 °F) is allowed as follows:

Range	Converter output current derating
50...55 °C (122...131 °F)	2.5% per 1 °C (1.8 °F) temperature increase

**Maximum temperature rise:** 13 °C (55.4 °F); depends on mass flow.

■ **Pressure limits**

**Base pressure:** 100...150 kPa (recommended); 200 kPa (maximum). Base pressure denotes the pressure of the system compared with the atmospheric pressure when the cooling circuit is filled with coolant.

**Maximum design pressure:** 500 kPa

**Recommended design maximum pressure:** 380 kPa.

**Note:** Contact ABB if you need to rise the pressure over this limit. The pressure difference must be within given limits to avoid malfunction due to excessive coolant flow.

**Nominal pressure difference:** 110 kPa / 120 kPa (hydrostatic)

**Maximum pressure difference:** 170 kPa / 180 kPa (hydrostatic)

■ **Water quality**

<b>Tap water</b>	
It is recommended to use demineralized or distilled water. The use of drinking water without gas/bubbles is allowed as follows:	
<ul style="list-style-type: none"> <li>•The water must fulfill the requirements of the Council Directive 98/83/EC of 3/11/98 on the quality of water intended for human consumption.</li> </ul>	
<b>Note:</b> The following requirements apply to the water to be used in the coolant, not the water-glycol-inhibitor mixture.	
pH value	6.0...8.0
Chloride	< 50 mg/l
Fluoride	< 50 mg/l
Sulphate	< 100 mg/l
Total dissolved solids	< 200 mg/l, no deposits are allowed at the temperature of +57 °C (153 °F)
Total hardness as CaCO <sub>3</sub>	< 250 mg/l
Conductivity	< 400 µS/cm (this equals the resistance of > 2500 ohm/cm)
The water must be clean of solid matter.	The use of purified water which is not intended for human consumption is forbidden.

■ **Freeze protection and corrosion inhibition**



**WARNING!**

Pay special attention to the composition of the coolant. Use the water-coolant mixture specified by ABB in the internal cooling circuit. Adding any other ingredient to the coolant may cause corrosion or dissolution of gaskets or adhesives used in couplings. It may also affect the viscosity of the coolant and degrade the cooling capacity of the cooling circuit and thus the load capacity of the converter. THE WARRANTY DOES NOT COVER DAMAGE OCCURRING FROM USE OF IMPROPER COOLANT.

### Coolant concentration

ABB recommends diluting coolant 50:50 with water. Note that the concentration of coolant should not be less than 33% and not more than 60%. Following table shows how the diluting portion effects to frost protection.

Frost protection down to	Coolant concentration	Water concentration
-20 °C (-4 °F)	33%	66%
-27 °C (-16.6 °F)	40%	60%
-38 °C (-36.4 °F)	50%	50%
-54 °C (-65.2 °F)	60%	40%



#### WARNING!

Operation at liquid temperatures below 0 °C (32 °F) is not permitted even with antifreeze.

### Coolant mixture quality

The pH level of the coolant **must not** be manipulated by adding chemicals not specified in this document. This may build up sediment in the liquid.

#### Approved coolants

- BASF Glysantin G30®, Valvoline Zerex G30®, Mobil Antifreeze Advanced or CLASSIC KOLDA UE G30 FG (1:1) READY MIX.

For other coolants, contact your local ABB representative.



#### WARNING!

Do not mix different approved coolants in any conditions! Replace the cooling liquid always with same cooling liquid! Mixing different coolant types is a risk for cooling system corrosion.

### ■ Materials

Materials used in the internal cooling circuit are:

- stainless steel AISI 316L (UNS 31603)
- heavy gauge aluminum
- plastic materials such as PA, PEX and PTFE
  - Note:** PVC hoses are not suitable for use with antifreeze.
- rubber gasket NBR (nitrile rubber).

Use only these materials in the external cooling circuit, too.



#### WARNING!

When connecting external piping to the internal cooling circuit, use only materials that are specified above. Copper and brass must not be used under any circumstances. Even minor dissolution of copper can cause copper precipitation on aluminum and subsequent galvanic corrosion. The liquid cooling system may not contain any zinc (for example, galvanized pipes) at all since zinc would react with the inhibitor.

## Cold start

### ■ First start in a commissioning

Before the converter is energized for the first time, adjust the setting of thermostat T1 from +5 °C to +60 °C (41 °F to 140 °F) to remove humidity from the auxiliary control cubicle with the fan heater. After the converter has been warmed up for one hour, change the setting to +5 °C (41 °F).

At the same time, it is recommended to start the heater and coolant circulation manually from the cooling station. Adjust the coolant temperature to a maximum possible level, +45...+50 °C (113...122 °F).

### ■ Normal start and start after blackout

When temperature of the thermostat T1 in the auxiliary control cubicle is below +5 °C (41 °F):

- There is no power supply for the control components in the auxiliary control cubicle.
- The auxiliary control cubicle is heated with heater E1.
- Heating request (relay K9.2) is ON: Turn the liquid heater and pump ON.
- Converter modules are being heated with water circulation.
- If the converter is equipped with the converter module heater option, the grid-side converter and the generator-side converter are heated with heaters E3, E4, E5 and E6.

When temperature of the thermostat T1 in the auxiliary control cubicle reaches +5 °C (41 °F), the control program of the converter is controlling the heating and dry-out sequence. For further details of the control program functions, see the firmware manual.

See also the circuit diagrams delivered with the converter.

---



---

# Further information

## **Product and service inquiries**

Address any inquiries about the product to your local ABB representative, quoting the type designation and serial number of the unit in question. A listing of ABB sales, support and service contacts can be found by navigating to [www.abb.com/searchchannels](http://www.abb.com/searchchannels).

## **Product training**

For information on ABB product training, navigate to [new.abb.com/service/training](http://new.abb.com/service/training).

## **Providing feedback on ABB manuals**

Your comments on our manuals are welcome. Navigate to [new.abb.com/drives/manuals-feedback-form](http://new.abb.com/drives/manuals-feedback-form).



[www.abb.com/windconverters](http://www.abb.com/windconverters)



3AXD50000466948B